





B.2

Montage- und Gebrauchsanleitung
Instructions for mounting and use
Notice de montage et d'utilisation
Montagehandleiding en handleiding
Instrucciones de montaje y uso
Ilstruzioni d'uso e montaggio

Standventil
Pillar Tap
Robinet de lave-mains
Koudwaterkraan
Válvula de pie
Rubinetto

B21080002010

	Wichtige Hinweise	4
	Important information	5
	Remarques importantes	6
	Belangrijke aanwijzingen	7
	Información importante	8
	Indicazioni importanti	9
	Montage, Installation, Montage, Montage, Montaje, Montaggio	10
	Bedienung, Operation, Commande, Bediening, Manejo, Comandi	11
	Pflege und Wartung, Care&maintenance, Entretien&maintenance, Onderhoudsinstructies, Conservación y mantenimiento, Cura&manutenzione	11



de

Diese Anleitung ist Bestandteil des Duravit Produkts und muss sorgfältig gelesen werden und jederzeit verfügbar sein.

Zielgruppe und Qualifikation

Das Produkt darf nur durch ausgebildete Sanitärinstallateure montiert werden.

Erklärung der Signalwörter und Symbole

ACHTUNG

Beschreibt Schäden, die nicht die Person betreffen.



Verweis auf Montagehinweis in diesem Kapitel



Aufforderung zum Sichten (z. B. auf Kratzer)



Aufforderung zum Prüfen auf Dichtigkeit



Aufforderung zum Tragen von Handschuhen

Technische Daten

Betriebsdruck	max. 0,5 MPa
empfohlen	0,3 MPa
Prüfdruck	0,5 MPa
1 MPa = 10 bar = 145 PSI	

Sicherheitshinweise

Schnitt- und Quetschverletzungen

- > Handschuhe tragen bei der Montage.

Produkt und/oder Sachschäden

- > Installationsvorschriften örtlicher Versorgungsunternehmen sowie länderspezifische Normen uneingeschränkt einhalten.

Montagehinweise

1 Spülen und silikonisieren (Grafik 01)

ACHTUNG

Funktionsstörung der Armatur durch verschmutzte Leitungen

- > Vor Montage der Armatur Leitungen nach den gültigen Normen spülen.

Wasserschäden

- > Leitungen mit essigsäurefreiem Silikon umschließen.



These instructions are part of the Duravit product and must be read carefully and kept available at all times.

Target readership and qualifications

The product may only be installed by a qualified plumber.

Explanation of the key words and symbols

NOTICE

Addresses practices not related to physical injury.



Link to the mounting instructions in this section



Prompt for inspection (e.g. for scratches)



Prompt to inspect for leaks and leak-tightness



Prompt to wear gloves

Technical data

Operating pressure	max. 0.5 MPa
Recommended	0.3 MPa
Test pressure	0.5 MPa
1 MPa = 10 bar = 145 PSI	

Safety instructions

Cut and crushing injuries

- > Wear gloves when installing the product.

Product and/or property damage

- > Observe the local installation regulations and any country-specific standards at all times.

Mounting instructions

1 Flushing and siliconising (diagram 01)

NOTICE

Tap unit malfunction due to dirty pipes

- > Flush the pipes according to the applicable standards before mounting the tap unit.

Water damage

- > Enclose pipes with silicone that does not contain acetic acid.

Cette notice de montage fait partie intégrante du produit Duravit. Elle doit être lue attentivement avant le montage et être disponible à tout moment.

Groupe cible et qualification

Le produit doit être monté uniquement par des installateurs sanitaires formés à cet effet.

Explication des avertissements et symboles

ATTENTION

Décrit des dommages qui ne concernent pas la personne.



Voir la consigne de montage dans ce chapitre



Invitation à vérifier (par. ex. les rayures)



Invitation à vérifier l'étanchéité



Invitation à porter des gants

Caractéristiques techniques

Pression de service	max. 0,5 MPa
Recommandée	0,3 MPa
Pression d'épreuve	0,5 MPa
1 MPa = 10 bar = 145 PSI	

Consignes de sécurité

Coupures et blessures par écrasement

> Porter des gants durant le montage.

Dommmages du produit et/ou des biens

> Les prescriptions d'installation des entreprises de fourniture locales et les normes nationales doivent impérativement être appliquées.

Consignes de montage

1 Rinçage et siliconage (graphique 01)

ATTENTION

Dysfonctionnement de la robinetterie dû à des conduites encrassées

> Rincer les conduites conformément aux normes en vigueur avant le montage de la robinetterie.

Dégâts des eaux

> Garnir les conduites de silicone exempt d'acide acétique.



Deze handleiding is een onderdeel van het Duravit-product en moet zorgvuldig worden gelezen en te allen tijde beschikbaar zijn.

Doelgroep en kwalificatie

Het product mag alleen door opgeleide sanitair installateurs worden gemonteerd.

Uitleg van de signaalwoorden en symbolen

LET OP

Beschrijft schade die geen betrekking heeft op personen.



Verwijzing naar montage-instructies in dit hoofdstuk.



Visuele controle noodzakelijk (bijv. i.v.m. krassen).



Er moet op dichtheid worden gecontroleerd.



Er dienen handschoenen te worden gedragen.

Technische gegevens

Werkdruk max. 0,5 MPa

Aanbevolen werkdruk 0,3 MPa

Testdruk 0,5 MPa

1 MPa = 10 bar = 145 PSI

Veiligheidsvoorschriften

Snijwonden en kneuzingen

> Draag tijdens de montage handschoenen.

Schade aan het product en/of materiële schade

> Neem de installatievoorschriften van de lokale nutsbedrijven alsmede de voor het betreffende land geldende normen volledig in acht.

Montage-instructies

1 Spoelen en silconeren (afbeelding 01)

LET OP

Functionele storting van de kraan door verontreinigde leidingen

> Voordat de kraan wordt gemonteerd, moeten de leidingen volgens de geldende normen worden gespoeld.

Waterschade

> De leidingen moeten met azijnzuurvrij silicone worden omsloten.



Estas instrucciones forman parte del producto Duravit y se deben leer detenidamente, además de estar disponibles en cualquier momento.

Instaladores y cualificación

El producto solo debe ser montado por instaladores sanitarios autorizados.

Explicación de las indicaciones y símbolos de advertencia

AVISO

Describe daños que no afectan a la persona.



Se refiere a una indicación de montaje en este capítulo



Comprobar de que no haya, (por ejemplo, arañazos)



Comprobar la estanqueidad



Ponerse sguantes

Características técnicas

Presión de funcionamiento	Máx. 0,5 MPa
Recomendada	0,3 MPa
Presión de comprobación	0,5 MPa
1 MPa = 10 bar = 145 PSI	

Advertencias de seguridad

Lesiones de corte y aplastamiento

> Llevar guantes durante el montaje.

Daños materiales o en el producto

> Deberán cumplirse de forma rigurosa las normativas de instalación de las empresas de suministro locales y las normas específicas de cada país.

Indicaciones de montaje

1 Aclarar y siliconizar (ilustr. 01)

AVISO

Fallo de funcionamiento en la grifería provocado por conductos sucios

> Antes de montar la grifería, aclarar los conductos según las normas vigentes.

Daños de agua

> Rellenar el espacio entre conducto y pared con silicona sin ácido acético.



Questo manuale è parte integrante del prodotto Duravit, deve essere letto con attenzione e deve essere disponibile in qualsiasi momento.

Destinatari e competenza

Il prodotto deve essere installato esclusivamente da tecnici specializzati e qualificati.

Spiegazione delle parole chiave e dei simboli

AVVISO

Descrive danni che non riguardano la persona.



Riferimento alla nota al montaggio in questo capitolo



Richiesta di ispezione visiva (ad es. per cercare graffi)



Richiesta di verifica della tenuta stagna



Richiesta di indossare i guanti

Dati tecnici

Pressione d'esercizio max. 0,5 MPa

Consigliata 0,3 MPa

Pressione di prova 0,5 MPa

1 MPa = 10 bar = 145 PSI

Indicazioni di sicurezza

Lesioni da taglio e schiacciamento

> Indossare i guanti per il montaggio.

Danni al prodotto e/o danni materiali

> Per l'installazione è necessario rispettare sempre rigorosamente le normative specifiche degli enti di approvvigionamento locali e le norme nazionali.

Indicazioni per l'installazione

1 Risciacquo e siliconatura (fig. 01)

AVVISO

Anomalia di funzionamento della rubinetteria a causa di tubazioni sporche

> Prima di montare la rubinetteria risciacquare le tubazioni secondo le norme vigenti.

Danni causati dall'acqua

> Avvolgere le tubazioni con silicone privo di acido acetico.

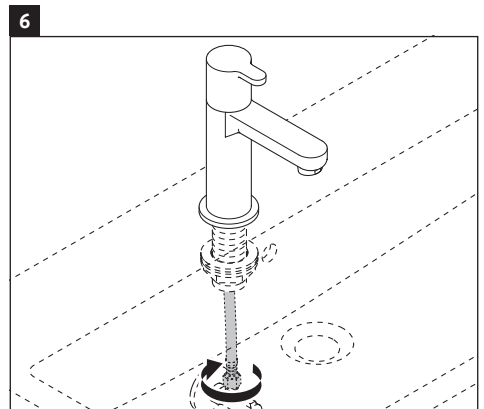
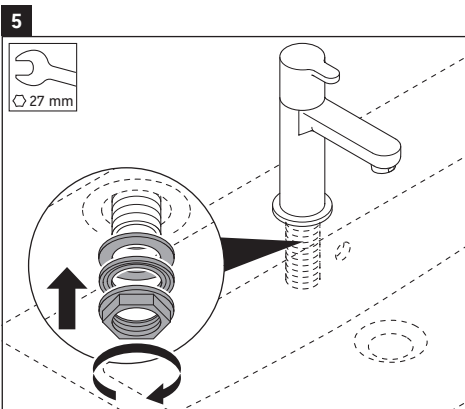
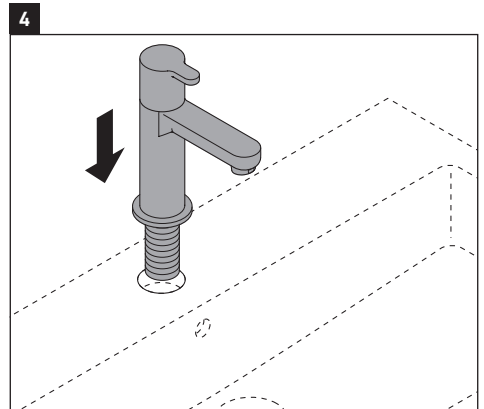
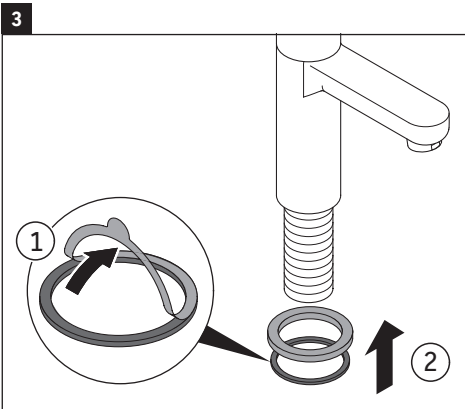
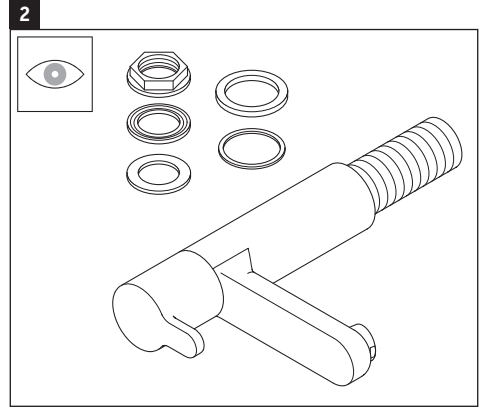
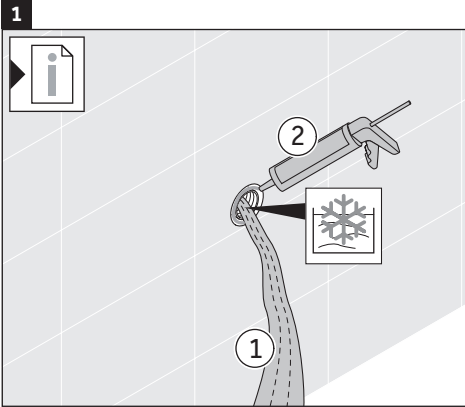

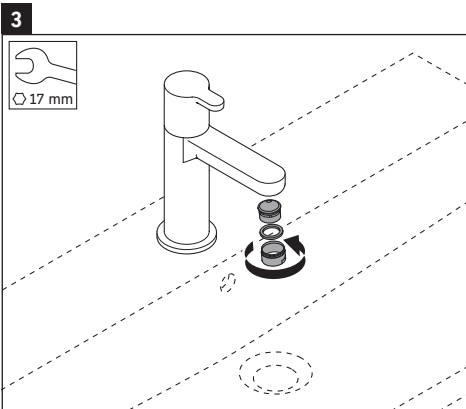
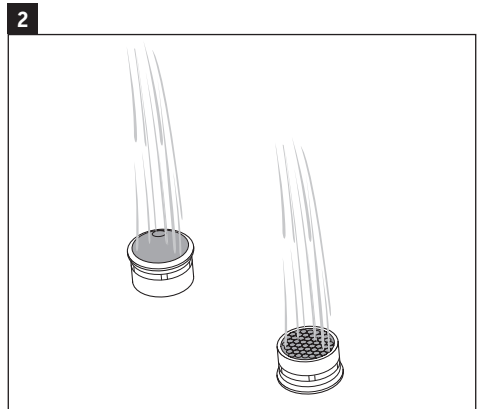
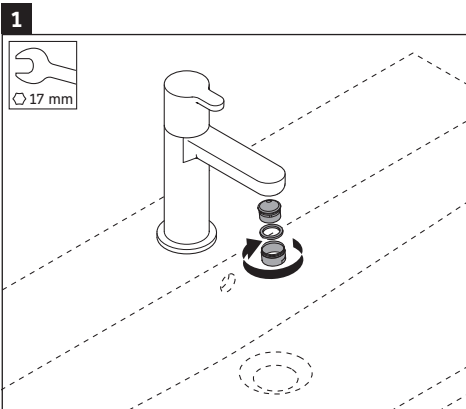
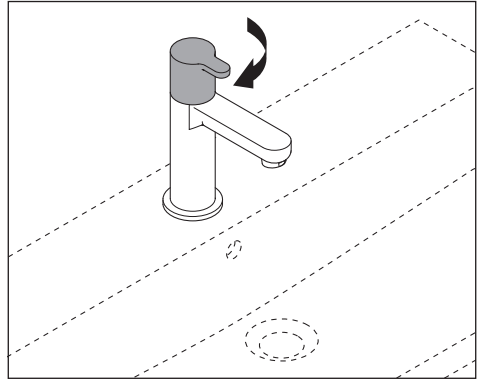
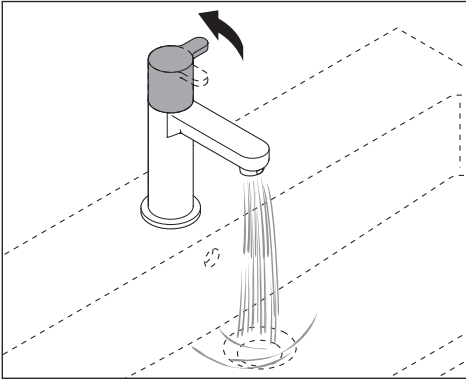

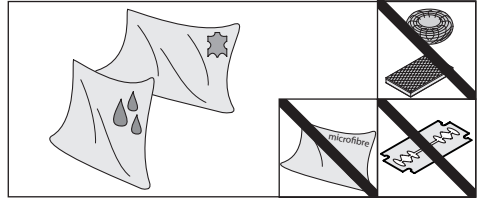
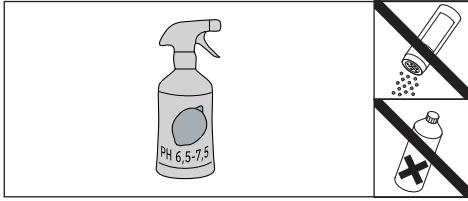

1

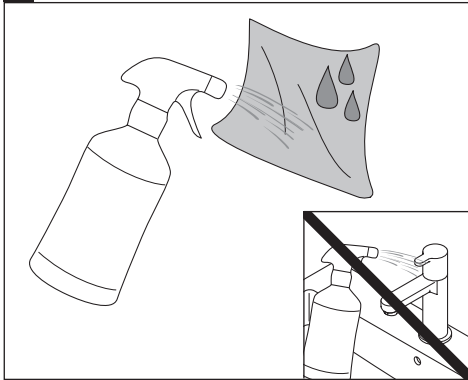

2

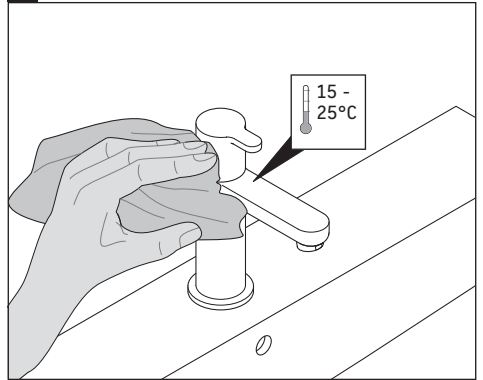

3

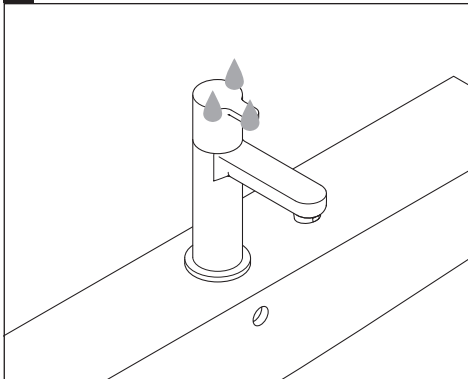

4

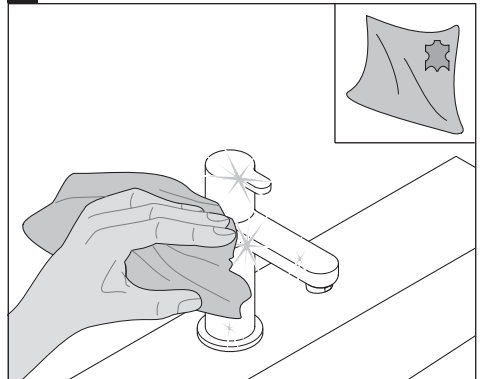

DURAVIT AG
P.O. Box 240
Werderstr. 36
78132 Hornberg
Germany
Phone +49 78 33 70 0
Fax +49 78 33 70 289
info@duravit.com
www.duravit.com

