

## Product information sheet ANDANO 500-IF/A

Item no. 525245

### Benefits

---



- Unique composition of optical and functional elements
- The harmonious interplay between the radii and surface design creates a modern appeal
- Elegantly designed wet area with an integrated tap ledge in just one worktop cut-out
- High quality features consisting of a covered C-overflow and InFino drain system with PushControl - the slim and intuitive remote control
- Large bowl capacity and fully utilisable base
- Optional premium accessories are available

## Planning information

---

- Additional drill hole possible for the individual 400-IF/A, 500-IF/A and 700-IF/A bowls. The subsequent drill hole should be carried out by a specialist company.
- With the double bowls 340/180-IF/A, 340/340-IF/A and 400/400-IF/A, additional drle hole is not possible.

## Scope of supply

---

- waste kit with space-saving pipe, 3 1/2" InFino basket strainer with drain remote control (PushControl), fixing kit

## Details

---

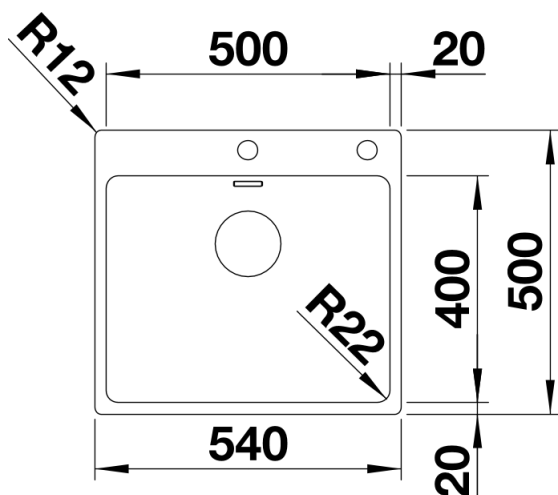

Top view

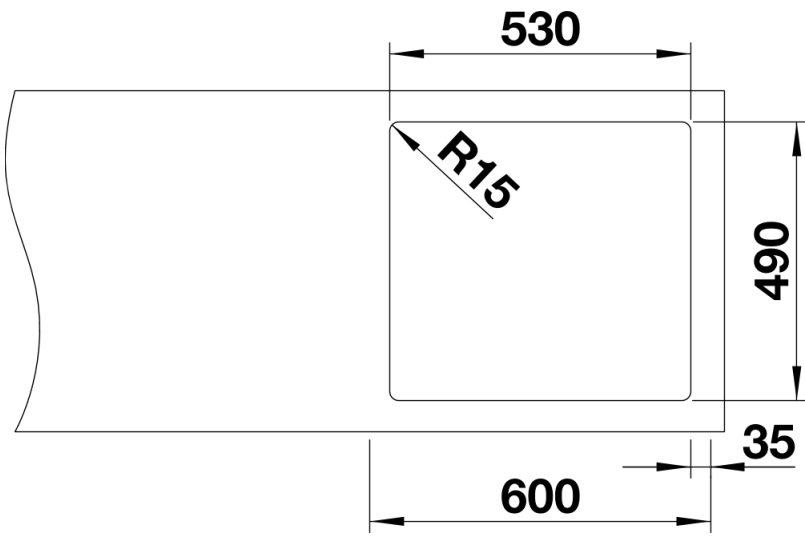

Cut-out

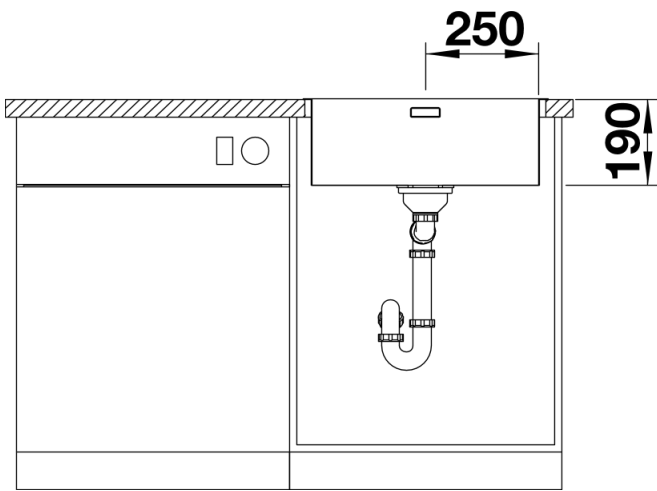

Front view

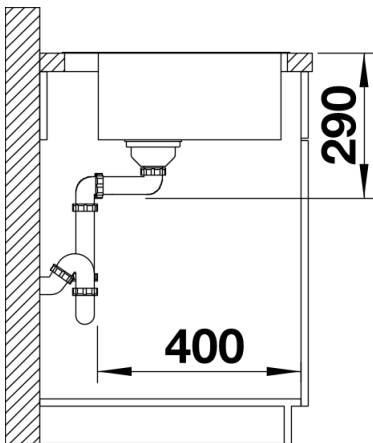

Side view