

## Product information sheet ETAGON 500-U

Item no. 522232

### Benefits

---



- Generous staggered bowl with the functionality of a sink centre
- Integrated step creates an additional functions level
- Innovative system concept with versatile ETAGON rails
- High-quality features with the covered C-overflow™ and InFino™ drain system – elegantly integrated and extremely hygienic
- For under mount installation, ideal in combination with high-quality worktops

### Colours

---

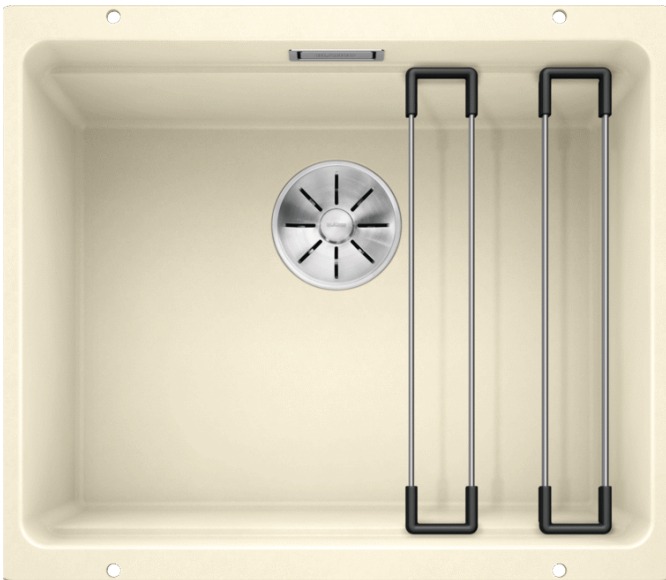

Available colours:

alu metallic  
pearl grey  
white  
jasmine  
anthracite  
tartufo  
rock grey  
coffee  
black

SILGRANIT® PuraDur® jasmine

## Scope of supply

---

- Two ETAGON rails in stainless steel, Waste fitting with space-saving pipe, 3 1/2" InFino™ basket strainer

## Details

---

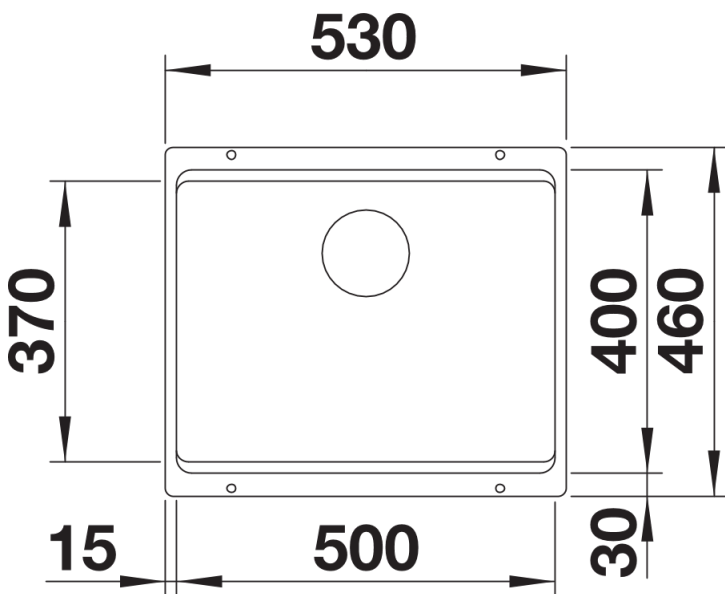

Top view

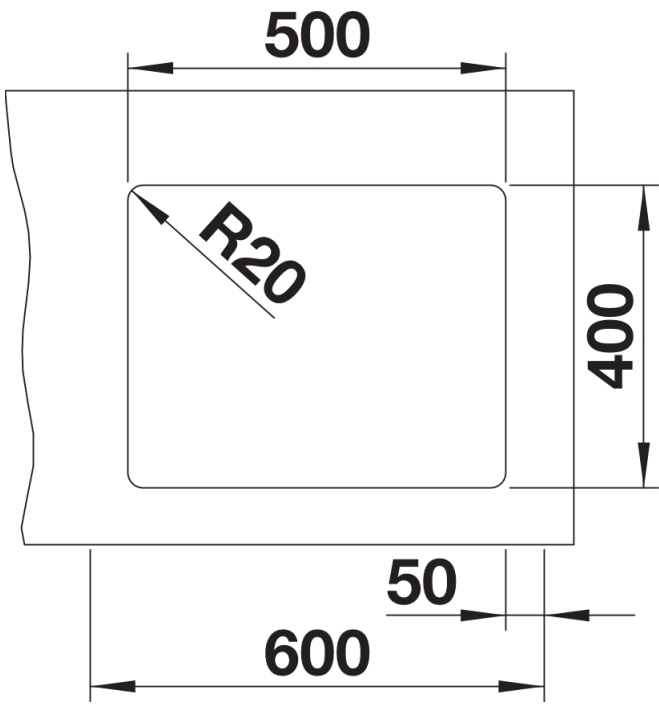

Cut-out

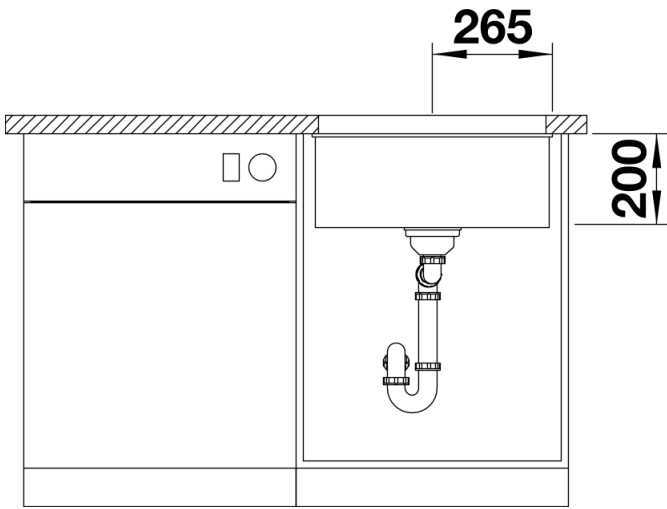

Front view

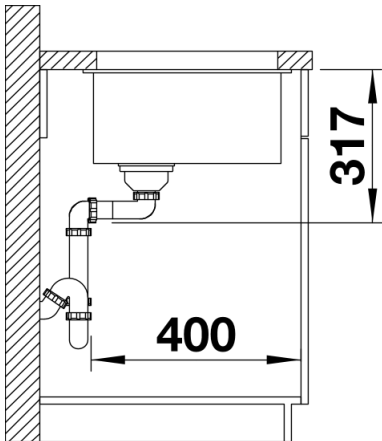

Side view