

iQ500, Ceiling cooker hood, 90 cm, Stainless steel LR96CAQ50B

B



The high-performance ceiling hood is designed with reduced height 18.9cm flat motor housing for flush installation, and is always at your service thanks to voice control.

- ✓ The quiet high-performance motor: ensures efficient odour and steam removal.
- ✓ The power level and the light of your hood can be adjusted by your hob with the cookConnect system or via the Home Connect App.
- ✓ Easily control the system with your voice - voiceControl
- ✓ Access and control your hood, no matter where you are - Home Connect App (Android and iOS)
- ✓ Control your system using the Home Connect App - remoteControl.

Features

Technical Data

Approval certificates : CE, VDE
 Length of electrical supply cord (cm) : 130
 Required niche size for installation (HxWxD) : 189mm x 886.0mm x 485mm
 Minimum distance above an electric hob : 650
 Minimum distance above a gas hob : 650
 Net weight (kg) : 24.304
 Type of control : Electronic
 Number of speed settings : 3-stage + 2 intensive
 Maximum output air extraction (m³/h) : 434
 Boost position output recirculating (m³/h) : 574.0
 Maximum output recirculating air (m³/h) : 336
 Boost position air extraction (m³/h) : 734
 Number of lights (Stck) : 4
 Noise level (dB(A) re 1 pW) : 61
 Diameter of air outlet (mm) : 150
 Grease filter material : Washable stainless steel
 EAN code : 4242003862926
 Connection rating (W) : 204
 Voltage (V) : 220-240
 Frequency (Hz) : 50; 60
 Plug type : GB plug
 Installation type : Island

Optional accessories

LZ21JXC51
 LZ21JXC21
 LZ21JCB11



iQ500, Ceiling cooker hood, 90 cm, Stainless steel LR96CAQ50B

Features

Key performance features:

- Energy Efficiency Class: B (at a range of energy efficiency classes from A+++ to D)
- Extraction rate according to EN 61591 ø 15 cm:
- max. Normal use 434 m³/h
- Intensive 734 m³/h
- Noise max. Normal Level: Noise, max. speed in normal us: 61 dB dB*

Home Connect: Remote Monitoring and Control

- cookConnect hob based hood control
- Voice Control enabled via popular voice assistants (only in countries where this service is available)
- Home Connect: Remote Monitoring and Control for connected home appliances and operation via smartphone or tablet (only in countries where Home Connect service is available)
- The Home Connect functionality can be extended by integrating numerous applications from external cooperation partners (partnerships)
- Adjustable color temperature (2.700 K - 5.000 K) for adaption to the room lighting available via Home Connect
- Interval function: available via Home Connect
- Silence function: available via Home Connect

Features

- 3 power levels and 2 intensive settings
- Automatic intensive revert (6mins)
- 4 x 3W LED Lights
- softLight with dimmer function
- Automatic after running (Automatic after running (10 minutes))
- Infrared remote control
- Efficient BLDC motor
- Twin channel high performance fan motor
- Interval operation
- Steel filter cover, Steel filter cover
- 2 x metal grease filter cassettes
- Grease and charcoal filter saturation indicators
- Easy to clean inner frame

Design

- Electronic control
- Rim ventilation
- Stainless Steel
- For ceiling mounted installation

Performance/technical information

- Suitable for ducted and re-circulating operation
- For recirculated extraction a recirculating kit or a CleanAir recirculation kit (accessory) is needed
- Max. extraction rate: 734 m³/h
- Extraction rate in recirculation mode:
- Max. normal use: 336 m³/h
- Intensive: 574 m³/h
- Noise level according to EN 60704-3 and EN 60704-2-13 exhaust air:
- Max. normal use: 61 dB(A) re 1 pW
- Intensive: 72 dB(A) re 1 pW
- Noise levels in recirculation mode:
- Max. normal use: 61 dB(A) re 1 pW

- Intensive: 74 dB(A) re 1 pW
 - Power rating: 204 W
 - Light Intensity: 659 lux
 - Colour Temperature: 3500 K
 - Electrical cable length 1.3 m
 - Diameter pipe Ø 150 mm (Ø 150 mm enclosed)
 - Dimensions exhaust air (HxWxD): 189-189 x 900 x 500 mm
 - Dimensions recirculating, chimney (HxWxD): 189-189 x 900 x 500 mm
 -
 - Blower Efficiency Class: A*
 - Lighting Efficiency Class: A*
 - Grease Filtering Efficiency Class: E*
 - Average Energy Consumption: 35.1 kWh/year*
- * In accordance with the EU-Regulation No 65/2014

**iQ500, Ceiling cooker hood, 90 cm,
Stainless steel
LR96CAQ50B**

Dimensioned drawings

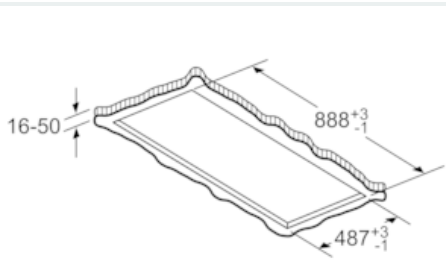

Never fit directly onto plasterboard or similar lightweight construction materials of the suspended ceiling. A suitable substructure is required that is securely fixed to the concrete ceiling.

measurements in mm

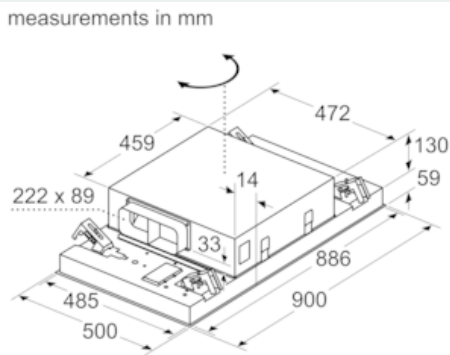

The fan outlet can be turned in all four directions

measurements in mm
Air extraction

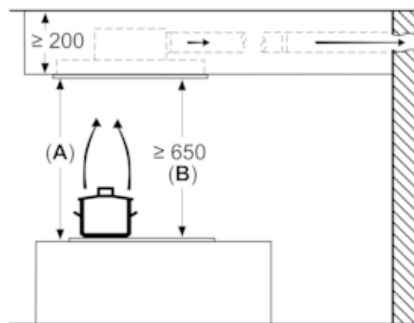

A: Optimum performance 700-1500
B: From upper edge of pan support

measurements in mm
Air recirculation

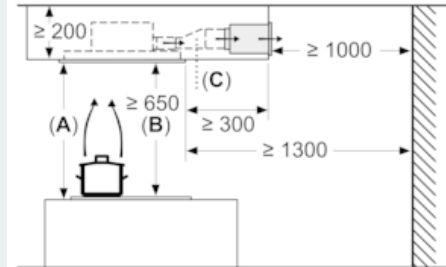

A: Optimum performance 700-1500
B: From upper edge of pan support
C: Connector (from a flat duct to a circular duct).
Not included in the scope of delivery.

measurements in mm
Air recirculation

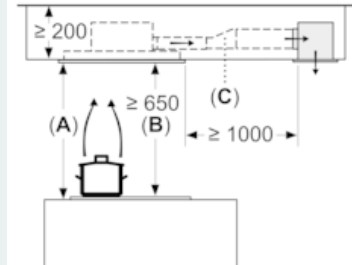

A: Optimum performance 700-1500
B: From upper edge of pan support
C: Connector (from a flat duct to a circular duct).
Not included in the scope of delivery.