

Serie | 6, Built-in freezer, 87.4 x 55.8 cm
GIV21AFE0



The freezer with 3 transparent freezer drawers and SuperFreezing: freezes new items placed inside even faster.

- **Automatic super freezing:** for freezing smaller food loads faster whilst protecting your frozen items from defrosting, thanks to the detection of temperature increase
- **BigBox frozen food drawer:** for stacking storage containers or for large frozen food items.
- **LowFrost:** defrost less often thanks to lower ice formation - saves work and is energy-efficient.
- An audible alarm system signals the door is open
- SuperFreeze

Technical Data

Energy Efficiency Class (Regulation (EU) 2017/1369):	E
Average annual energy consumption in kilowatt hour per year (kWh/a) (EU) 2017/1369:	176
Sum of volume of frozen compartments (EU 2017/1369):	96
Airborne acoustical noise emissions (EU 2017/1369):	36
Airborne acoustical noise emission class (EU 2017/1369):	C
Thermometer freeze section:	None
Light:	No
Product category:	Upright freezer
Construction type:	Built-in
Door panel options:	Not possible
Frost free system:	No
Height of the product (mm):	874
Width of the appliance:	558
Depth of the product:	545
Dimensions of the packed product (HxWxD) (mm):	950 x 640 x 620
Net weight (kg):	39.838
Gross weight (kg):	42.6
Connection rating (W):	90
Current (A):	10
Frequency (Hz):	50
Approval certificates:	CE, VDE
Length of electrical supply cord (cm):	230
Door hinge:	Right reversible
Storage Period in Event of Power Failure (h):	13
Defrost process:	manual
Warning signal / malfunction:	visual and audible
Lockable door:	No
Number of drawers/baskets (Stck):	3
Number of freezing flaps (Stck):	0
EAN code:	4242005126996
Brand:	Bosch
Product name / Commercial code:	GIV21AFE0
Product category:	Upright freezer



Serie | 6, Built-in freezer, 87.4 x 55.8 cm GIV21AFE0

The freezer with 3 transparent freezer drawers and SuperFreezing: freezes new items placed inside even faster.

Design features

- LowFrost - less ice creation and therefore quicker defrosting - less ice build up, faster defrosting
- Fixed hinge
- LED electronic control
- SuperFreeze function with automatic deactivation
- Freezer malfunction warning signal: optical, acoustical

Freezer Section

- 3 transparent freezer drawers, including 1 BigBox

Technical Information

- Right hinged door, door reversible
- Connection value 90 W
- 220 - 240 V

Dimension and installation

- Niche Dimensions: 88 cm H x 56 cm W x 55 cm D
- Dimensions: 87.4 cm H x 55.8 cm W x 54.5 cm D

Accessories

- ice cube tray

Included accessories

- KFZ20AX0, KFZ20SX0

Country Specific Options

- Based on the results of the standard 24-hour test. Actual consumption depends on usage/position of the appliance.

Additional features

Performance and Consumption

- EU19_EEK_D: E
- Total Volume : 96 l
- Freezing capacity 24h : 5 kg
- Annual Energy Consumption: 176 kWh/a
- Climate Class: SN-T
- Noise Level : 36 dB
- Temperature rise time : EU19_Temperature rise time_D: 13 H

Serie | 6, Built-in freezer, 87.4 x 55.8 cm
GIV21AFE0

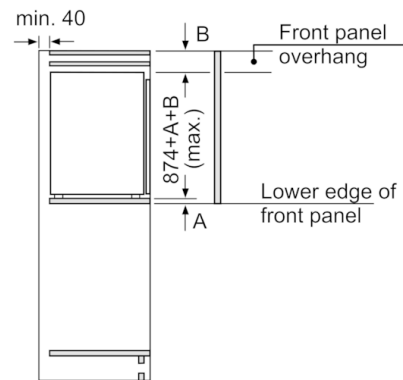
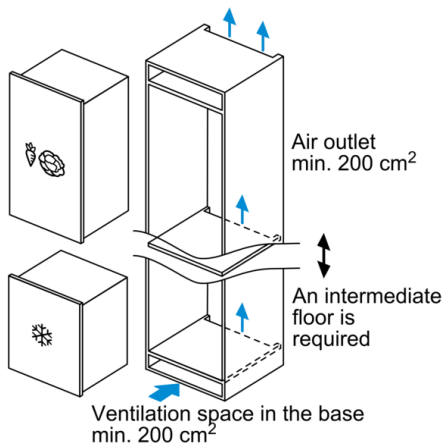

measurements in mm

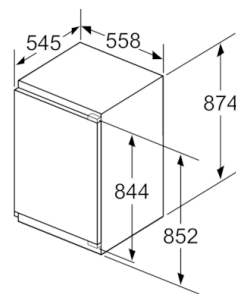
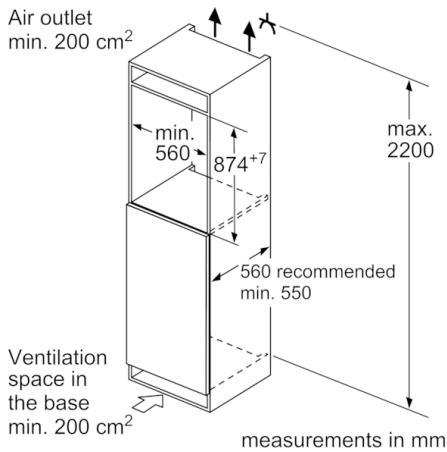

measurements in mm

measurements in mm
 Recommended gap dimensions for flat hinges

F	R	X
16-19	0-3	2.5
20	0-1	3
	2-3	2.5
21	0-1	3
	2-3	2.5
22	0	4
	1	3.5
	2-3	3

The gap dimensions recommended in the table must be adhered to in order to ensure that appliance doors do not collide with anything when they are opened, and to avoid causing damage to kitchen units.