

## iQ500, Built-in freezer, 177.2 x 55.8 cm GI81NAEFOG



very energy efficient freezer with electronic temperature control.

- ✓ noFrost technology prevents icing and frosting so you never have to defrost again.
- ✓ superFreezing - Sensors automatically reduce the temperature for a set period of time, to quickly freeze newly added food items.
- ✓ All freezer drawers and glass shelves can be removed easily. varioZone lets you organize the space flexibly.
- ✓ bigBox: Extra-large storage space to store frozen foods flexibly
- ✓ Electronic temperature control: set the target temperature clearly and easily.

### Features

#### Technical Data

Energy Efficiency Class (Regulation (EU) 2017/1369): F  
 Average annual energy consumption in kilowatt hour per year (kWh/a) (EU) 2017/1369: 294  
 Sum of volume of frozen compartments (EU 2017/1369): 212  
 Airborne acoustical noise emissions (EU 2017/1369): 36  
 Airborne acoustical noise emission class (EU 2017/1369): C  
 Thermometer freeze section: Digital  
 Light: No  
 Product category: Upright freezer  
 Construction type: Built-in  
 Door panel options: Not possible  
 Frost free system: Fridge and freezer  
 Height of the product (mm): 1772  
 Width of the appliance: 558  
 Depth of the product: 545  
 Dimensions of the packed product (HxWxD) (mm): 1840 x 640 x 620  
 Net weight (kg): 63.766  
 Gross weight (kg): 69.0  
 Connection rating (W): 120  
 Current (A): 13  
 Frequency (Hz): 50  
 Approval certificates: CE, VDE  
 Length of electrical supply cord (cm): 230  
 Door hinge: Left reversible  
 Storage Period in Event of Power Failure (h): 8  
 Warning signal / malfunction: visual and audible  
 Lockable door: No  
 Number of drawers/baskets (Stck): 5  
 Number of freezing flaps (Stck): 2  
 EAN code: 4242003863039  
 Brand: Siemens  
 Product name / Commercial code: GI81NAEFOG  
 Product category: Upright freezer



## iQ500, Built-in freezer, 177.2 x 55.8 cm GI81NAEF0G

### Features

- No Frost, Built-in tall freezer

#### Design features

- No Frost, never have to defrost ever again
- Left-mounted, reversible door
- Electronic control (LED display)

#### Key features - Freezer section

- Vario Zone - removable safety glass shelves for extra space!
- 5 freezer drawers
- SuperFreeze function with automatic deactivation
- ice cube tray

#### Functions

- Freezer malfunction warning signal: optical, acoustical

#### Dimension and installation

- Niche Dimensions: 177.5 cm H x 56 cm W x 55 cm D
- Dimensions: 177.2 cm H x 55.8 cm W x 54.5 cm D
- Connection value 120 W
- 220 - 240 V
- Based on the results of the standard 24-hour test. Actual consumption depends on usage/position of the appliance.

#### Performance and Consumption

- EU19\_EEK\_D: F
- Total Volume : 212 l
- Net Fridge Volume : 0 l
- Net Freezer Volume : 212 l
- Freezing capacity 24h : 13.8 kg
- Annual Energy Consumption: 294 kWh/a
- Climate Class: SN-T
- Noise Level : 36 dB
- Temperature rise time : EU19\_Temperature rise time\_D: 8 H

**iQ500, Built-in freezer, 177.2 x 55.8 cm  
GI81NAEFOG**

Dimensioned drawings

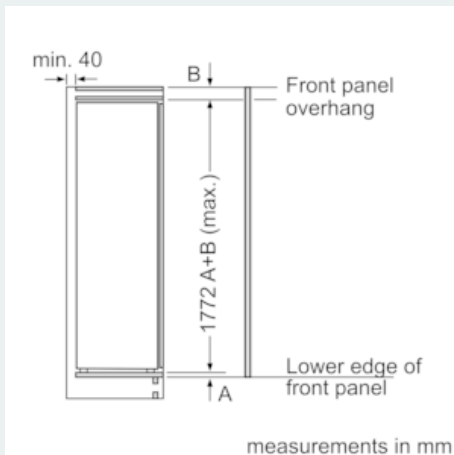
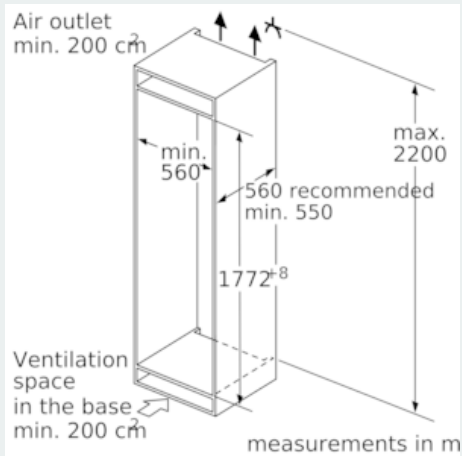
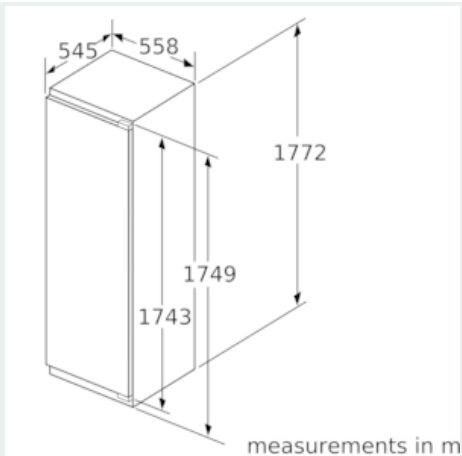

Maximal permissible weight of the unit fronts

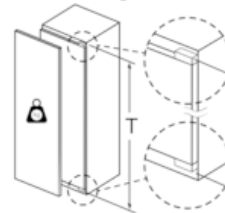

Fitted kitchen unit doors that exceed the permissible weight may cause damage and result in functional impairment of the hinges.

T: Includes height of appliance door Hinges in mm:	undamped hinge, Door in kg:	damped hinge, Door in kg:
1500-1750	22	22

measurements in mm

Recommended gap dimensions for flat hinges

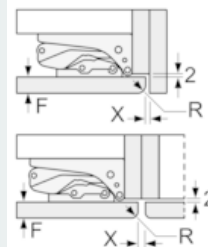

F	R	X
16-19	0-3	2.5
20	0-1	3
	2-3	2.5
21	0-1	3
	2-3	2.5
22	0	4
	1	3.5
	2-3	3

The gap dimensions recommended in the table must be adhered to in order to ensure that appliance doors do not collide with anything when they are opened, and to avoid causing damage to kitchen units.