

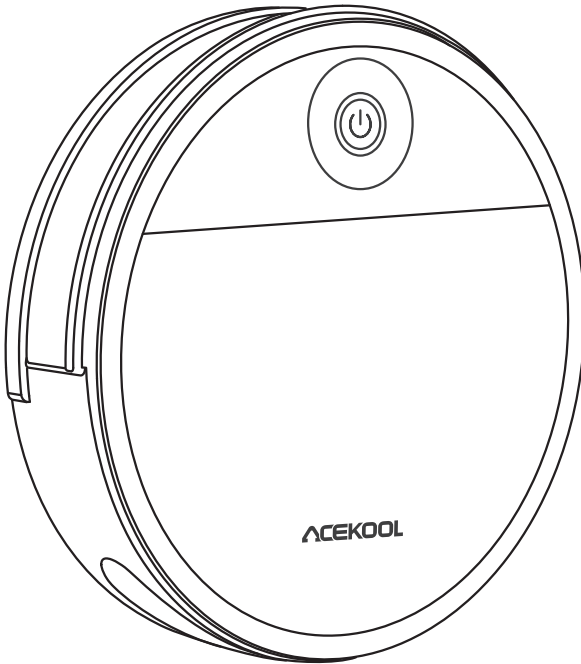

Robot Vacuum Cleaner C11

INSTRUCTION MANUAL



Thank you for purchasing Acekool Robot Vacuum Cleaner. Before operating this unit, please read these instructions completely and keep the manual ready for further reference.

CONTENTS

■ Important Safety Instructions	01
■ Product Composition	03
■ Technical Parameters	05
■ Operating and Programming	06
■ Maintenance	11
■ Lighting Effect and Alarm	14
■ Troubleshooting	15
■ WIFI Manual	18

Important Safety Instructions

When using this product, be sure to stay vigilant and stick to the instructions below:

- Children from the age of 8 years old and upwards as well as people with specific impairments may: use/clean/maintain appliance, but only under strict supervision and after being briefed about instructions and possible hazards. This appliance should not be used as a toy.
- Before using, make sure to clear the area that is to be cleaned by the robotic vacuum cleaner. Remember to remove any cords and small objects that could become an obstacle for the appliance, this includes, carpets with fringes that should be tucked inwards, tablecloths and curtains that should be lifted away from floor.
- If there is any sort of step or ledge where the appliance is operating, operate it in such a way that it detects the ledge or put up a barrier along the ledge (watch out for tripping).
- Only use the appliance in the way described in this manual. Only use attachments recommended or sold by the manufacturer.
- Please make sure your power supply voltage matches the power voltage marked on the charging dock.
- This appliance is explicitly for indoor domestic use only. Do not use the appliance outdoors, commercially or in industrial environments.
- Do not use it without dust bins and filters in place.
- Do not operate the appliance in an area where there are lit candles or fragile objects.
- Do not use appliance in extremely hot or cold environments (below 23°F or above 104°F).
- Keep hair, loose clothing, fingers and all parts of body away from any openings and moving parts.
- Do not operate the appliance in a room where an infant or child is sleeping.
- Do not use appliance on wet surfaces or surfaces with standing water.
- Do not allow the appliance to pick up large objects like stones, large pieces of paper or any items that may clog the appliance.
- Do not use appliance to pick up flammable or combustible materials such as gasoline, printer/copier toner or use in areas where such materials may be present.
- Do not use appliance to pick up anything that is burning or smoking, such as cigarettes, matches, hot ashes or anything that could cause a fire.
- Do not let objects be sucked up by appliance. Stop using if the suction tube gets blocked. Keep the tube clear of dust, lint, hair or anything that may reduce air flow.
- Take care not to damage the power cord. In this regard, do not pull on or carry the appliance or charging dock by the power cord or use the power cord as a handle or close a door on the power cord or pull power cord around sharp edges or corners or run the appliance over the power cord. Keep the power cord away from hot surfaces.

- To avoid a hazard, immediately report to the service center if the power cord is compromised.
- Do not use the charging dock if it is damaged. If the charging dock is not working properly, has been dropped, damaged, left outdoors or come in contact with water, it must be repaired by the manufacturer or the service agent in order to avoid a hazard.
- Turn OFF the power switch before cleaning or doing maintenance on the appliance.
- The appliance must not be in the charging dock when cleaning or doing maintenance.
- When disposing of appliance, it is vital that the battery is taken to a battery disposing depot. Before removing the battery, be sure to remove the appliance from the charging dock.
- The battery must be removed and discarded according to local laws and regulations before disposal of the appliance.
- Do not incinerate the appliance, even if it is severely damaged. The batteries can explode in a fire.
- When not using the charging dock for a long period of time, please unplug it. The appliance must be used in accordance with the directions in this Instruction Manual. Acekool cannot be held liable for any damages or injuries caused by improper use.
- If the robotic vacuum cleaner will not be used for a long time, fully charge the robotic vacuum cleaner, switch OFF the power for storage and unplug the charging dock.

Product Composition

Robot

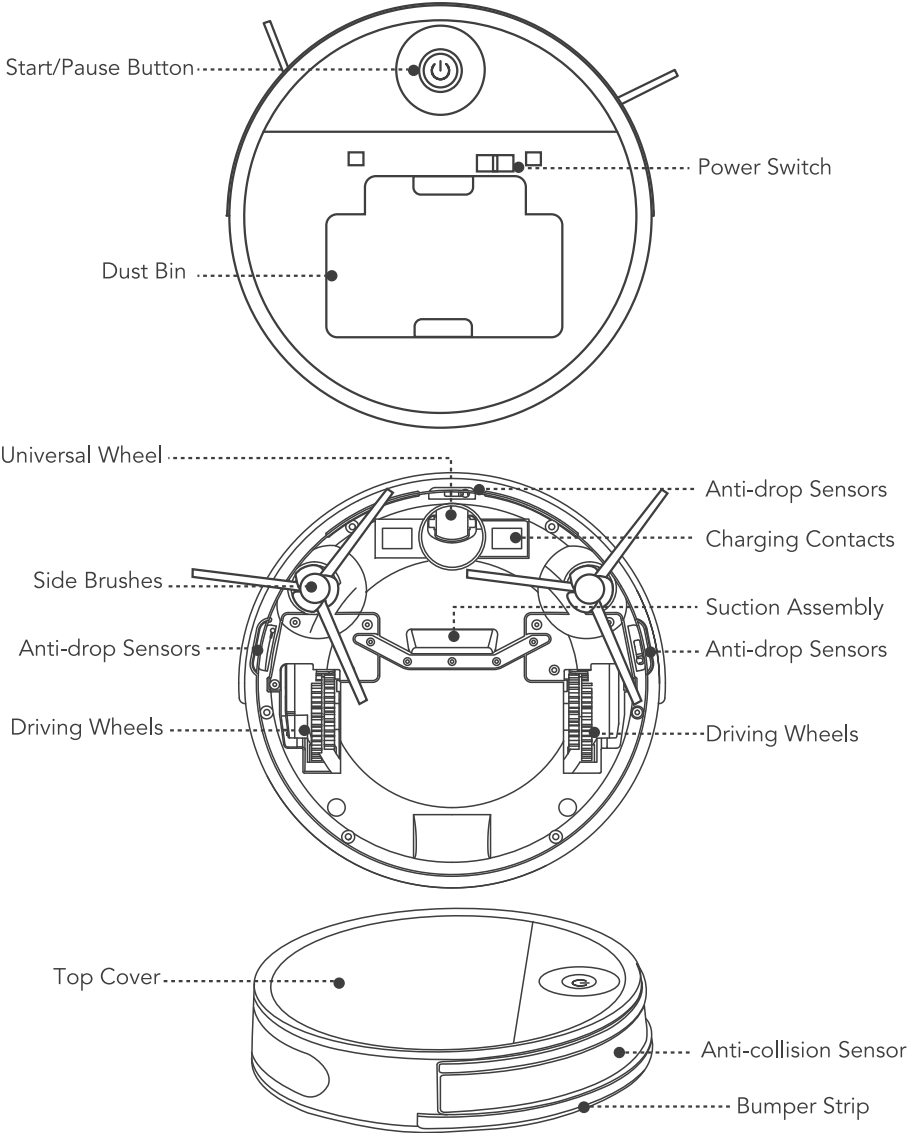

Charging Dock

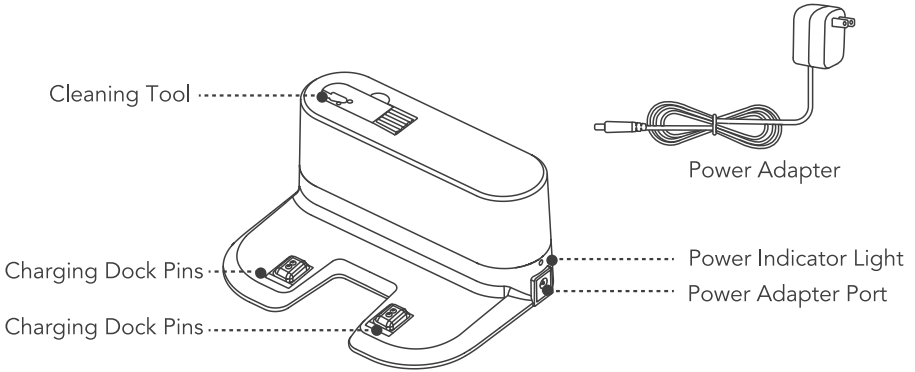

Dust Bin

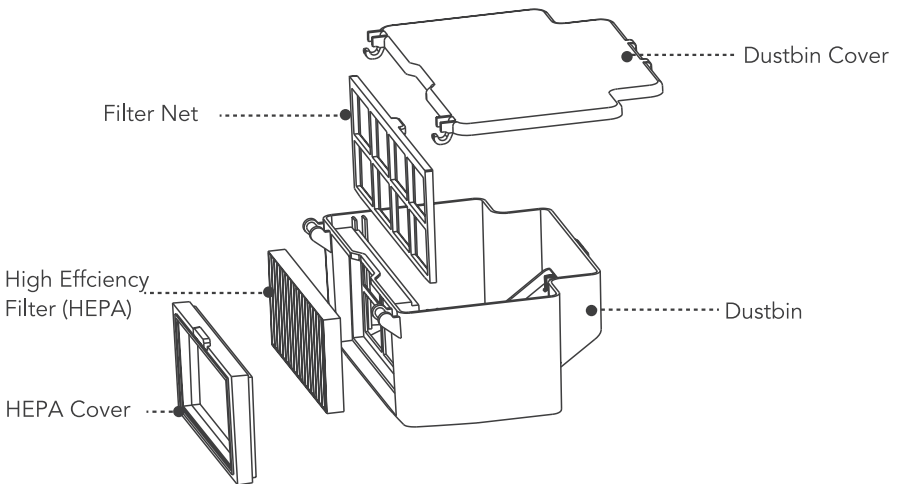

Structure of Remote Controller

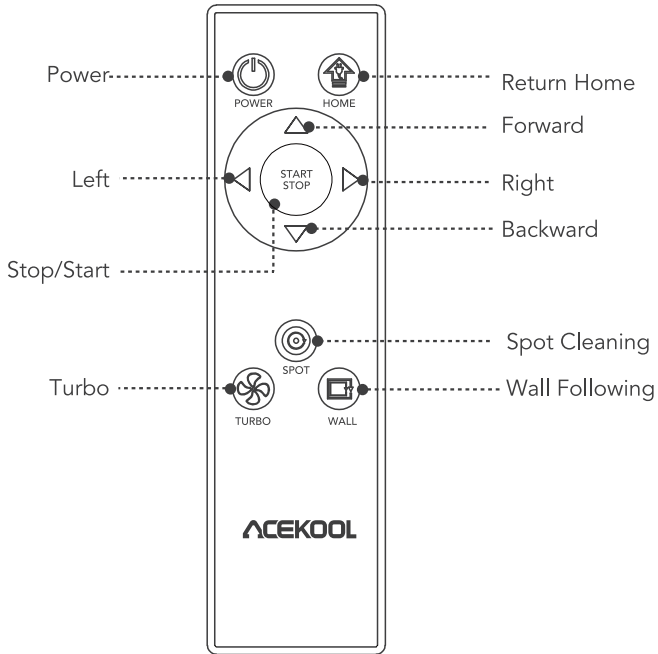

Technical Parameters

Working Voltage: 14.8V ==
Rated Input Voltage: 19V ==

Power Rating: 25W
Rated Output Current: 0.6A

Operating and Programming

Notes Before Cleaning

Please refer to the following guidelines to check the cleaning area before using the robot.

- Remove any power cords and small objects from the floor that could cause the appliance to get entangled.

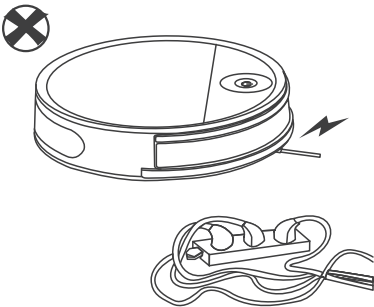

- Fold the fringe of carpets underneath themselves, left up curtains, avoid cleaning thick/dark/piled up rugs.

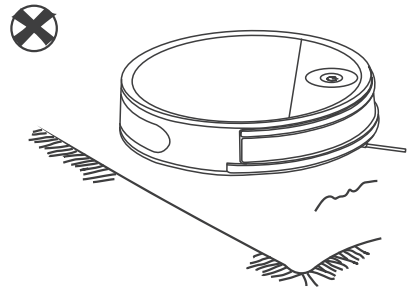

- Remove any power cords and small objects from the floor that could cause the appliance to get entangled.

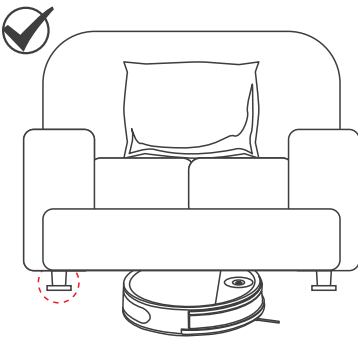

- Fold the fringe of carpets underneath themselves, left up curtains, avoid cleaning thick/dark/piled up rugs.

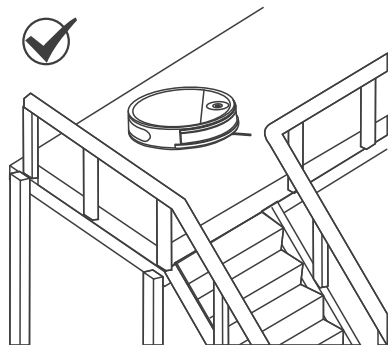

- Robot may climb on top of object less.

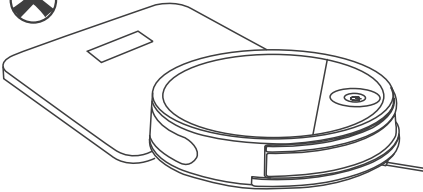

- Keep Robot away from wet, flame and burning.

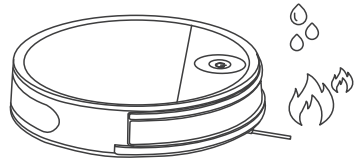

Quick Start

◆ Charging Guidelines

- Connecting the adapter to the charging Dock

Place the charging dock on a level-floor-surface and against a wall, the base must be perpendicular to the ground. Keep the immediate area (2m (6.6') in front of the charger and 1m (3.3') on both sides of the charger clear of objects and reflective surfaces. Plug the charging dock in to power source. The "Power Indicator Light" should glow on.

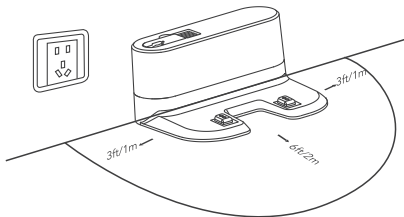

Place the charging dock against a wall and perpendicular to the floor.

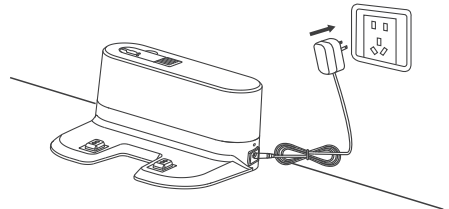

Connect to power source.

- Install Side Brushes

Attach Side Brushes to the bottom of robot by pressing a brush into each slot until it clicks.

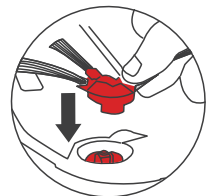
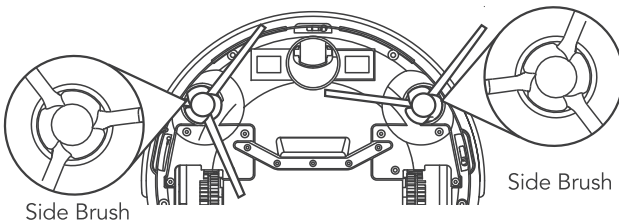

◆ Start Charging Process

- Turn on the power

Open the unit top cover, push the switch to "I" ("I" is for turn ON, "O" is for OFF). When the robot is finished working, please don't turn off. It is better practice to put straight on to charge so it is prepared for next use.

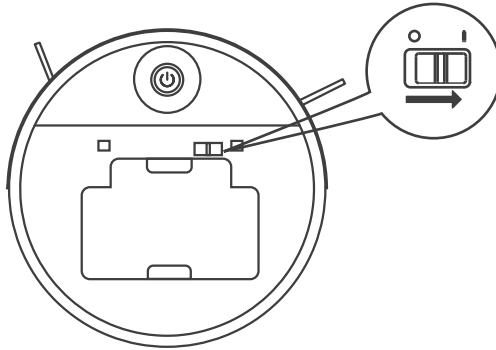

- Charging Instructions

Please make sure the charging pins on the docking station are aligned correctly within the contact area on the main unit. The ⏻ button light is flickering when the unit is charging. The indicator light will stop flickering when completely charged. The charging time usually takes 5.5 hours if the battery is very low.

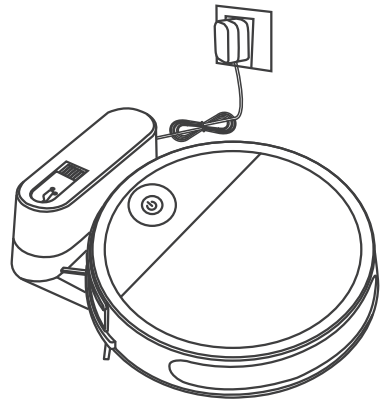

The contact area on the charging dock should make a successful connection with the charging pins.

◆ Charge Robot Cleaner

1. In order to start or stop cleaning, press the Start button (⏻) key or the remote control's (⏻) / (⏻) key respectively.

Note: Before starting the robot, make sure that the outer ring of the (⏻) key is white and the robot has been activated. If the robot does not start up, briefly press the (⏻) key to start it up. The appliance will enter into sleep mode after 10 minutes of standby and the key light will turn off.

2. If you need to select another mode, please refer to the "Mode Selection" section.

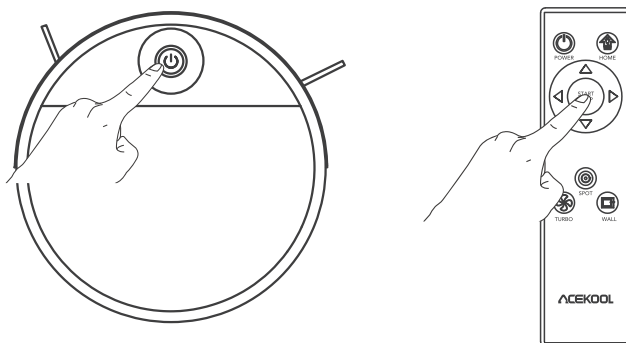

● Mode Selection

In order to adapt to different ground conditions and achieve deep cleaning, this product has a variety of cleaning modes, which can be selected by remote control as needed. The remote control can switch between any mode directly.

Before switching the mode, make sure that the outer ring of the (⏻) key is white and the appliance is on. If the appliance does not activate, briefly press the (⏻) key to wake it up.

◆ Auto Mode

It is suitable to use appliance in a concentrated ground area where there is a lot of dirt. The Robot will centralize cleaning in the designated area with the "spiral" route.

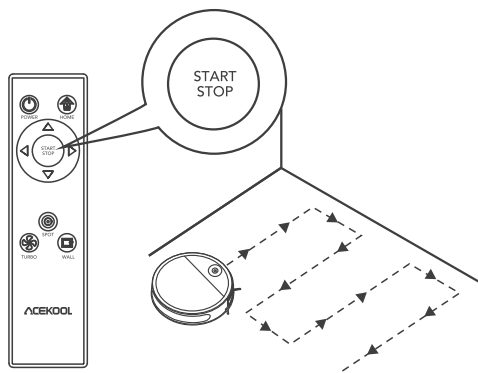

◆ Edge Mode

It is suitable for cleaning in the corners of the room. The Robot will clean around the periphery of a fixed object (such as a wall) and will return to the charging dock after cleaning.

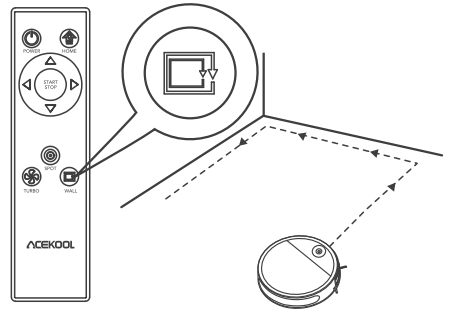

◆ Return to Charging Mode

If the appliance senses its power is insufficient during the cleaning process, it will automatically find the charging stand for charging. You can select the "Remote control home" button or select the "equipment home" button twice to make the appliance return to the charging stand for charging.

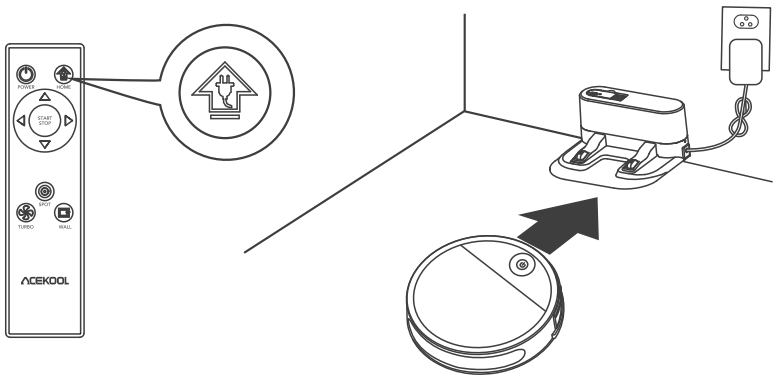

Maintenance

Dust Bin and Filters

- Open the middle cover to take out the dust bin bag, open the dust bin cover and empty. Remove the dust bin, open the dustbin cover and empty.

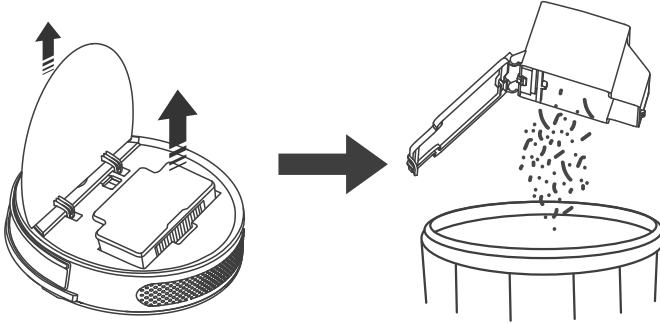

- Remove dust filter. HEPA does not recommend for washing filter. Rather, pat the High Efficiency Filter clean.

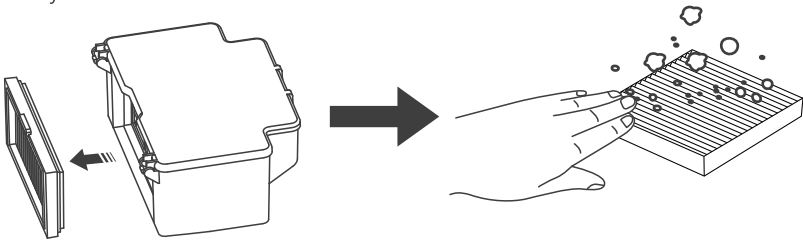

- Flush out the Dust Bin and clean the Filter Net.

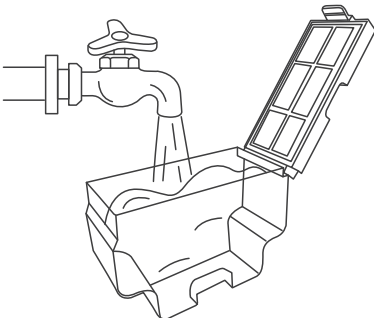

- Dry the Sponge filter, Dust Bin and Filter Net completely before reinstalling.

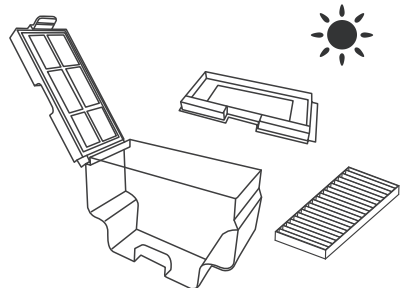

Suction Assembly and Side Brush Use

- Clean the suction port. If there is a lot of dust in the suction port, use a cloth to clean it up.

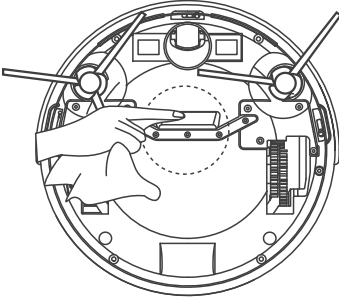

- Cleaning the Side Brushes requires removing the Side Brushes. Wipe the Side Brushes and their slots down with a dry cloth.

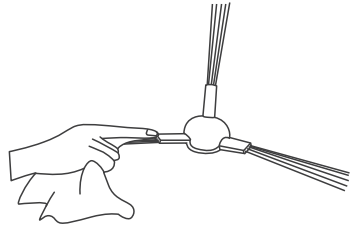

- Clean the driving wheel in order to maintain its effectiveness.

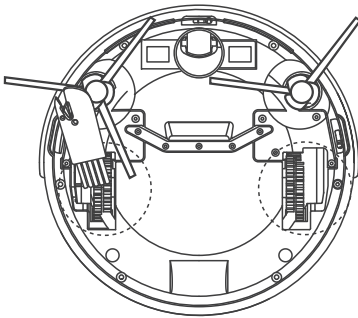

- Use the multi-function cleaning tool to cut off and remove any hair tangled around the universal wheel.

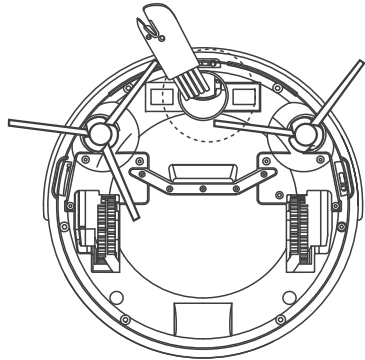

Other Components

- Clean the anti-collision sensor panel.

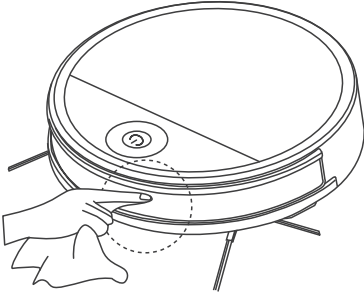

- Wipe the anti-drop sensors with the brush or the felt side of the multi function cleaning tool to maintain the sensors effectiveness.

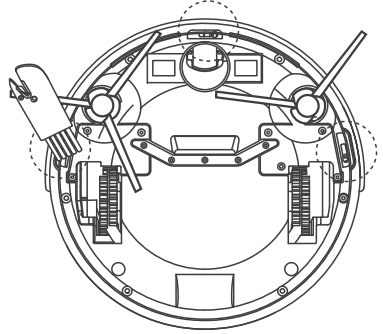

- To maintain their effectiveness, wipe the charging contacts and charging dock pins using the brush of the "MultiFunction Cleaning Tool" or alternatively, a dry clean cloth.

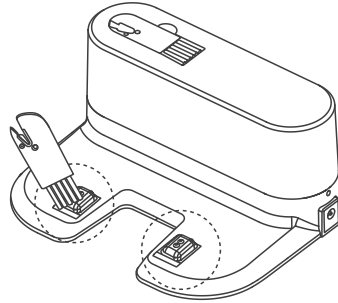
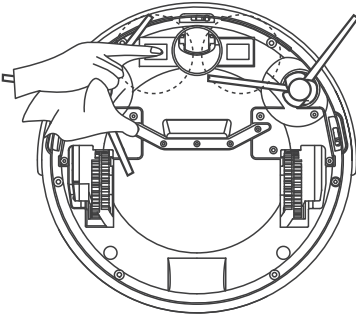

Lighting Effect and Alarm

Indicator Light

Status	AUTO Display Status
Charging	White light in breathing state
Finished Charging	The light will stop flickering
Low Battery	Glows a continuous RED
Before starting network pairing	a. Paired status: red light will flash 3 times and then switch to constant light state. b. Unpaired status: white light will remain in constant light state.
Network pairing process/WiFi connection lost	White light in flashing state.
Connect to Wi-Fi	White light in constant light state.

Alarm Tip

When the robot fails, the robot indicator flashes red and a beeping sound of varying lengths is emitted. Refer to the following table to query the cause of the failure:

Red Light Glows a continuous RED (APP alarm prompt only applies to Acekool MT-210)

Cause of issue	Beeps	APP Error prompts and solutions
Driving wheel abnormality	1 beep 3 times	The wheel is entangled. The driving wheel is clogged with dirt (if so, clean) or the driving wheel is abnormal and ought to be fixed.
Side brush abnormality	2 beeps 3 times	The motor fan is abnormal. Clean out the appliances' dustbin bag as well as unclogging and cleaning the air ducts.
Motor fan abnormality	3 beeps 3 times	The side brush is acting abnormally. Please check if the side brush is entangled and/or needs to be cleaned.

Red light flashes

Cause of issue	Beeps	APP Error prompts and solutions
Anti-fall detection alarm	2 beeps 3 times	The robot is not on solid ground, please move to the ground.
Out of trouble alarm	3 beeps 3 times	Appliance is stuck or in trouble. Remove it from situation.
Low Battery	4 beep 3 times	Battery is too low.
Power Adaptor	5 beeps 3 times	Charging voltage is abnormal, please replace the adapter.
Charging abnormality	6 beeps 3 times	Charging voltage is abnormal, please replace the adapter.

If the problem cannot be resolved according to the above troubles shooting, Please try the following actions. Press the power switch on the side of the robot and restart the robot.

Troubleshooting

Please use this chart to troubleshoot common problems using robot.

Malfunction	Possible Causes	Solutions
Can not connect to WIFI (applicable to MT-210).	Incorrect WIFI name or Password.	Please make sure the WIFI name and the password are entered correctly.
	Make sure the robot is less than 5 feet (0.5 meter) away from the router and your phone is as close as possible.	Ensure the robot is under WIFI signal coverage.
	Didn't connect to the 2.4G Wi-Fi signal.	Make sure the robot is in the network pairing mode.
	Robot isn't in network pairing mode.	The robot is not compatible with the 5G WIFI signal. Please connect to 2.4G WIFI signal.

Malfunction	Possible Causes	Solutions
Can not connect to WIFI (applicable to MT-210).	Downloaded the incorrect APP.	Please scan the QR code in the user manual or search on Google play or app store.
The robot is too noisy.	The side brush or rolling brush is entangled and the dustbin filter material blocked, etc.	It is recommended to clean and maintain the brush, roller brush, dustbin and filters regularly.
	The robot is in MAX suction power mode.	Change the suction power mode to Medium or Low.
Robot will not Charge.	The Robot is not connecting to the Charging Dock.	Be sure that the robot's charging contacts have made a connection with the charging dock Pins.
	The charging dock is unplugged while the robot is powered ON, causing battery consumption.	Plug in the charging dock and ensure the robot is powered ON. Keep the robot on the Charging Dock to make sure it has a full battery to work at any time.
Robot gets into trouble while working and stops.	The robot is entangled or obstructed by scattered wires on the ground, draped curtains or carpet edges.	Robot will try various ways to get itself out of trouble. If it is unsuccessful, manually remove the obstacles and restart.
	Side Brush is stuck or the rotation speed of the side Brush decreases.	Remove the debris tangled around the Side Brush. If the Side Brush still rotates slowly, contact Customer Service.
	Roller Brush is stuck or the rotation speed of the Roller brush decreases.	Remove the debris tangled around the roller Brush with the provided Multi-Function Cleaning Tool. If the Roller Brush still rotates slowly, contact Customer Service.

Malfunction	Possible Causes	Solutions
<p>Robot returns to the Charging Dock before it finishes cleaning.</p>	<p>When battery power gets low, the robot automatically switches to Return to Charger Mode and returns to the Charging Dock to recharge itself.</p>	<p>This is normal. No solution necessary.</p>
	<p>Working time varies according to floor surface, room complexity and the selected Cleaning Mode.</p>	<p>This is normal. No solution necessary.</p>
<p>Remote Control failure (effective control range of Remote Control is 5m/16 feet).</p>	<p>The batteries in the Remote Control need to be replaced.</p>	<p>Replace the battery with a new one and install it properly.</p>
	<p>Robot is powered OFF or the robot's battery is low.</p>	<p>Make sure the robot is powered ON and fully charged.</p>
	<p>The infrared signal cannot be transmitted because the Infrared Emitter on the Remote Control or the robot's Infrared Receiver on the robot is dirty.</p>	<p>Use a dry cloth or the Multi-Function Cleaning Tool to wipe the Infrared Emitter on Remote Control and the Infrared Receiver on the robot.</p>
<p>There is other equipment interfering with the infrared signal to the robot.</p>	<p>Avoid using the Remote Control near other equipment using infrared signals.</p>	

WIFI Manual

- Scan the bar code below to download the Tuya WIFI APP, "Tuy Smart".
- Open the APP "Tuy Smart", register your account by using your phone number or email etc.
- Select "Add Device"
- Select, "Add Manually", then click "Small Home Appliance", then choose "Robot Vacuum" (WIFI).

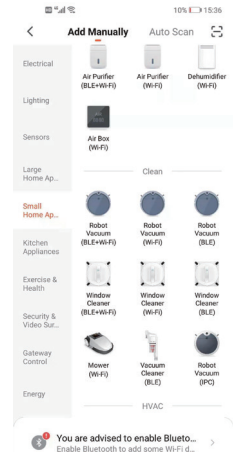
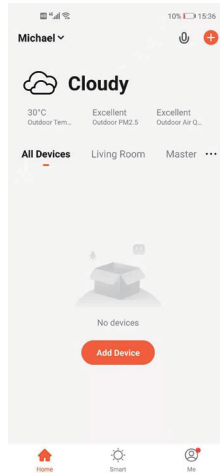

- Open the top cover, turn the switch to "1", hold down the  button for 3 seconds, you will hear a voice of "Di", then the robot will enter into network mode.

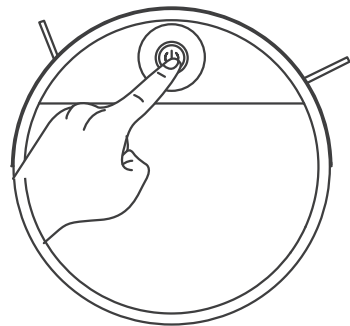
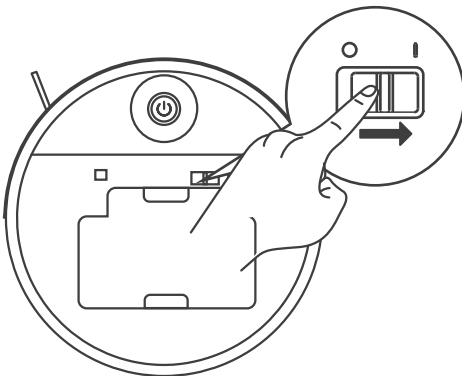

- Select the available network, this appliance only supports 2.4GHz. Enter the correct WIFI password, click to confirm.
- After confirmed, the "Connecting" progress of the robot will be displayed.
- After the connection is successful, it will show "Device added successfully".

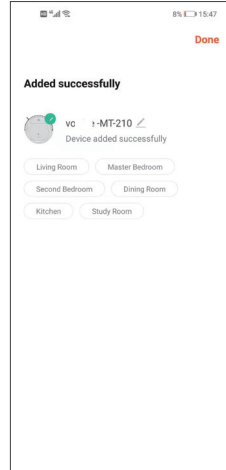
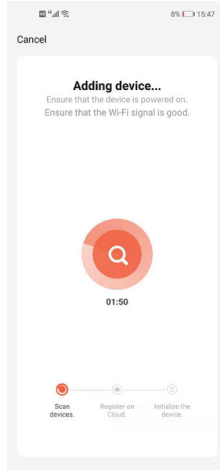
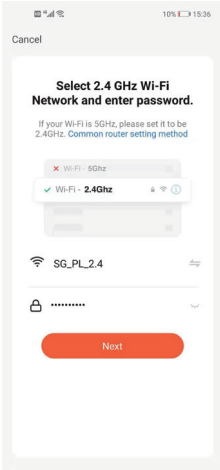

- You can now enter the operation interface to control the robot.
- Select "Settings", you will see "Timer", select it to add schedule cleaning for robot.

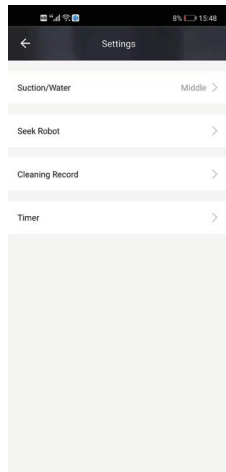
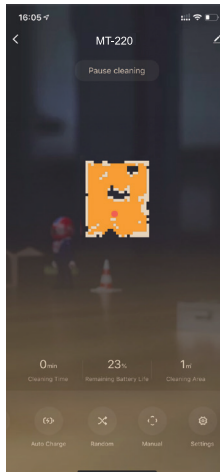
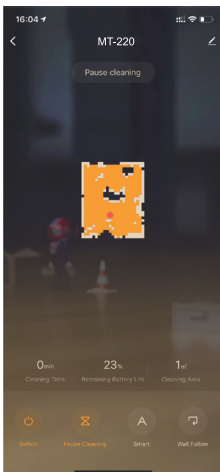

ACEKOOOL

— Make Life Easier —

Model: MT-210

Email: support@acekool.vip

Website: <https://www.acekool.vip>

Made in China

