

**ACEKOOL**

Leading A Better Life

**ACEKOOL**

Leading A Better Life



## AIR PURIFIER B-D01 USER MANUA

Questions or Concerns?  
please contact us at : [support@acekool.vip](mailto:support@acekool.vip)

FC



Made In China

# THANK YOU FOR PURCHASING THE Air Purifier B-D01 BY ACEKOOL.

Should you have any questions or concerns regarding your new product, please reach out us at [support@acekool.vip](mailto:support@acekool.vip).

We hope you enjoy your new product!

## TABLE OF CONTENTS

Package Contents	3
Specifications	3
Safety Information	4
Getting to Know Your Air Purifier	7
Getting Started	8
Operation	9
· Button Controls	9
Keeping Things Clean	10
· General Maintenance	10
· Checking the Air Filters	11
· When Should I Replace the Air Filters?	11
· Replacing the Air Filters	12
· Resetting the Air Purifier	14
Troubleshooting	15
Warranty Information	17
Customer Support	18

## PACKAGE CONTENTS

- 1 x B-D01 Air Purifier
- 1 x Activated Carbon & HEPA Filter (Pre-installed)
- 1 x USB cable
- 1 x User Manual

## SPECIFICATIONS

Power Supply	DC 5V
Rated Power	3.5W
Effective Range	85 ft <sup>2</sup> (8-10 m <sup>2</sup> )
Operating Conditions Temperatur	14°F~104°F (-10°C~40°C)
Dimensions	≤25 dB
Dimensions	140*140*287mm
Net Weight	0.9KG

## SAFETY INFORMATION

**IMPORTANT:** Please read and comply with all of the instructions and warnings provided in this manual before using the product. Failure to comply with the instructions and warnings provided herein may result in inaccurate results and/or damage to the product itself.

### GENERAL SAFETY

Only use this air purifier as described in this manual. Ensure the plug fits properly into a polarized power outlet.

- When not being used, turn the air purifier off and disconnect it from its power source by removing the plug from the electrical outlet.
- DO NOT operate the unit if cord or plug is damaged. Doing so may result in injury or damage to the unit.
- DO NOT handle the unit with wet hands. Thoroughly dry your hands before handling any part of the air purifier.
- DO NOT immerse air purifier in water or liquids. Doing so may result in damage to the appliance, electric shock, or fire.
- DO NOT use the air purifier in wet or humid environments.
- DO NOT use the air purifier outdoors. This appliance is designed for indoor use only.
- DO NOT use the purifier in a room with major indoor temperature changes as this may cause condensation to build up inside the appliance.
- DO NOT use the air purifier in an enclosed space where flammable, combustible or explosive gases are present.
- DO NOT use in an area where toxic vapours, flammable dust or oxygen tanks are present.

- It is important to keep all objects away from the air intake grill.
- DO NOT insert fingers or objects into the air outlet.
- Child supervision is required while the air purifier is on. Do not allow children to play on or near the air purifier.
- CAUTION: This appliance does not remove carbon monoxide (CO) or radon (Rn). It cannot be used as a safety device to prevent or clean up accidents with combustion processes and hazardous chemicals.

## USE & CARE

Always make sure to place the air purifier on a flat, level surface before operation.

- Always allow 15 inches (38 cm) of clearance on all sides of the purifier.
- WARNING: To reduce the risk of fire or electric shock, do not use the appliance with any solid-state speed control device.
- Place the air purifier so that the power cord easily reaches a standard electrical outlet for a polarized plug.
- DO NOT run the power cord under carpeting. Do not cover cord with throw rugs, Runners or similar coverings.

DO NOT ROUTE CORD UNDER FURNITURE OR APPLIANCES.

Place the power cord away from high traffic areas.

- DO NOT use an extension cord with this unit.
- Never place the unit on soft surfaces such as a bed or sofa.
- This air purifier should not be used as a substitute for kitchen or bathroom ventilation or vacuum cleaning.

- DO NOT sit on or place anything on top of the purifier
- DO NOT place the purifier directly below an air conditioner to prevent any moisture from getting into the purifier.
- DO NOT place the air purifier near sources of heat, such as stove tops, ovens, radiators or computers.
- DO NOT place open flames, including candles, directly in front of the air purifier.
- DO NOT use this appliance with indoor smoke-type insect repellents or in places with oily residues, burning incense, or chemical fumes.
- This appliance should only be used in rooms with temperatures between 14°F and 104°F.
- Always unplug the appliance from the power supply before servicing.

This unit should be inspected frequently. Dirt that has collected should be removed regularly to prevent excessive accumulation that may result in flashover or fire.

- DO NOT clean the appliance with water or any other liquid to avoid electric shock and/or electrical fires.
- Only use B-D01 replacement filters for this unit. Do not attempt to use other filters with this appliance.
- If you experience any problems while operating the air purifier, refer to the Troubleshooting section on page 15. If you are still having problems with your air purifier, contact Customer Support on page 18.
- If the unit is damaged or is not functioning properly, immediately discontinue use and contact Customer Support (page 18).
- DO NOT attempt to repair this device in any way or use any replacement components or parts to modify the air purifier. Doing so will void your warranty. Contact Customer Support immediately if your appliance is no longer working

## GETTING TO KNOW YOUR AIR PURIFIER

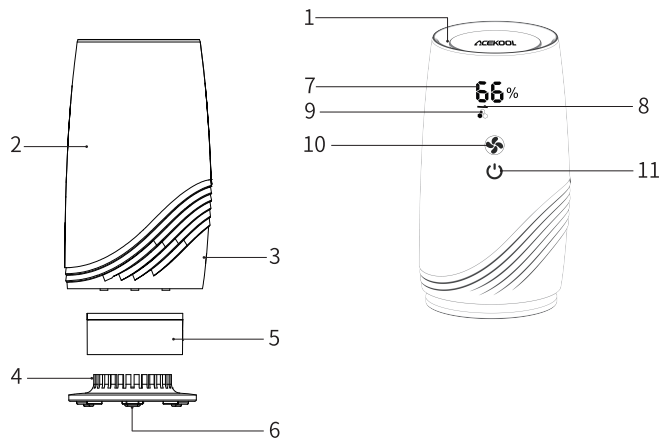

- |                                  |  |
|----------------------------------|--|
| 1. Air exit                      | 7. Digital indicator: Temperature/Humidity |
| 2. Body                          | 8. Fan speed                               |
| 3. Power cord hole               | 9. Filter replacement indicator            |
| 4. Air inlet                     | 10. Speed                                  |
| 5. HEPA +activated carbon filter | 11. Power                                  |
| 6. Filter cover                  |  |

## GETTING STARTED

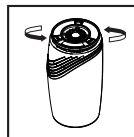

1. Rotate the filter cover counterclockwise to the slot position, and then remove the cover.

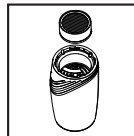

2. Remove the filter from the plastic packaging, and then reinstall the filter. White HEPA filter It should face outwards.

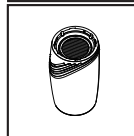

3. Replace the filter cover on the air purifier and make sure that the buckle of the filter cover enters the slot of the base. Twist filter Rotate clockwise and close the filter cover after hearing a click.



4. Place the touch screen upward and place the air purifier on a stable surface.



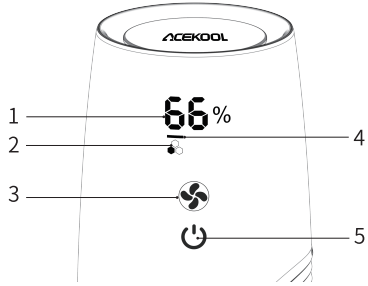

**NOTE:** • Always allow 15 inches of clearance on all sides of the purifier. [Figure 1.6]  
• Ensure the air filter is properly positioned in the purifier before use.



# OPERATION



1. Digital indicator: Temperature/Humidity
2. Filter replacement indicator
3. Speed
4. Fan speed
5. Power

## Button Controls

-  **Power button**  
Tap once to turn on or turn off the air purifier.
-  **Fan Speed Button**  
Tap ‘’ to cycle through the 2 fan speeds of the air purifier. Long press for 3 seconds to enter sleep mode, Any key to exit sleep mode.  
LOW I / HIGH II
-  **Temperature and humidity display**  
Display the current temperature and humidity value and switch every 5 seconds.

-  **Check filter indicator**  
This button will light up when the air filters need to be checked or replaced. Tap and hold ‘’ for 5 seconds after checking or changing the air filters (See Checking the Air Filters on page 11).
-  **Sleep mode**  
In the "sleep" mode, only the power button indicator will remain lit, and The machine will run at LOW I mode speed.

# KEEPING THINGS CLEAN

## General Maintenance

- Wipe down the housing with a soft, clean cloth.
- DO NOT immerse the purifier in water or liquid detergents.
- If necessary, wipe the housing with a clean damp cloth, then immediately dry the housing with a separate clean cloth.

## Checking the Air Filters

The '●●●' will light up to remind you to check the air filters. Please note, This is simply a reminder to check the air filters. The button will light up on sooner or later depending on how often you use your air purifier. It does not necessarily mean it is time to change the filters.

## When Should I Replace the Air Filters?

It is recommended to change the air filters every 6–8 months. However, you may need to change your filters sooner or later depending on how often you use your air purifier. It is important to watch out for the following signs of expired filters:

- Increased operating noise
- Decreased airflow
- Clogged filters
- Increased presence of odors

### NOTE:

- The environment in which the air purifier being used may also extend or shorten the lifetime of the air filters. Using your air purifier in an environment of relatively high pollution may mean you will need to change the air filters more often.
- If the air pollution in your environment is very high, there is a possibility that the filters may not be completely effective and may need to be replaced before '●●●' lights up.
- Remember to reset the air purifier after changing the air filters.

## AIR FILTERSLEAN

### Replacing the Air Filters

1. Turn off and unplug the air purifier.
2. Flip over the purifier and remove the filter cover. [Figure 2.1 & 2.2]

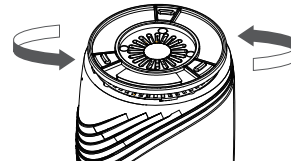

Figure 2.1

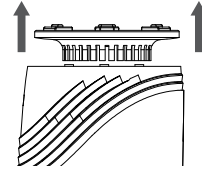

Figure 2.2

3. Remove the old filters. [Figure 2.3]
4. (Optional) Clean any remaining dust or hair inside the purifier using a vacuum hose [Figure 2.4]. DO NOT use water or liquids to clean the purifier.

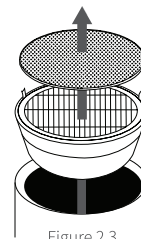

Figure 2.3

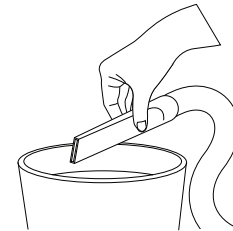

Figure 2.4

5. Remove the new filters from their packaging and place them into the purifier with the pull tabs facing out. The white HEPA filter should also be facing out with the gray pre-filter on top of it. [Figures 2.5 & 2.6]

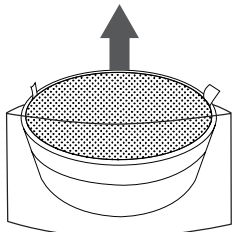

Figure 2.5

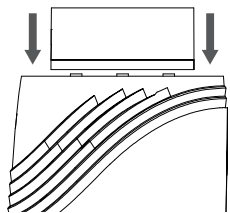

Figure 2.6

6. Replace the filter cover onto the housing, making sure the arrows on the housing and filter cover align. Turn the filter cover clockwise to the lock position. [Figures 2.7 & 2.8]
7. Follow the instructions in the Resetting the Air Purifier on page 12 to complete the filter replacement process.

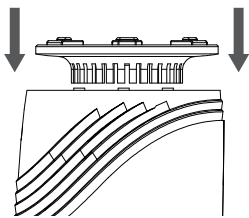

Figure 2.7

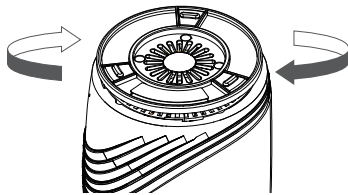

Figure 2.8

## Resetting the Air Purifier

The air purifier must be reset if ‘’ lights up, and after checking or replacing the air filters.

1. Plug in the air purifier and turn it on.
2. Press and hold the "Power On Button Icon" for 5 seconds.
3. The indicator light stops flashing, indicating that the reset is complete.



# TROUBLESHOOTING

Problem	Cause	Solution
Air purifier does not power on.	Unit is not plugged into an electrical outlet.	Connect the plug to a powered electrical outlet.
	Outlet is not working properly.	Try plugging the air purifier into a different outlet.
	Power button has not been pressed after plugging in the air purifier.	Press '⏻' once to turn on the air purifier.
	Power cord is damaged.	Immediately discontinue use and contact Customer Support (page 18).
Air purifier is defective or malfunctioning.	Air purifier is defective or malfunctioning.	Immediately discontinue use and contact Customer Support (page 18).
	Air purifier is not plugged into an outlet.	Connect the plug to a powered electrical outlet.
Air purifier does not respond to button controls	Air purifier is defective or malfunctioning.	Immediately discontinue use and contact Customer Support (page 18).
Air purifier makes an unusual noise while operating.	Air filters are dirty.	Replace the air filters as instructed in the Replacing the Air Filters section on page 12.
	Filter does not fit properly.	Properly place filter(s) as noted in the Getting Started and Replacing the Air Filters sections (pages 8 and 12).
	Foreign object inside the unit.	Immediately discontinue use and contact Customer Support (page 18). DO NOT attempt to open the air purifier.
Significantly reduced airflow.	Filter packaging has not been removed.	Remove filter from packaging before use.
	Fan speed is low.	Press '⏻' to adjust fan speed.
	Air filters need to be replaced.	Replace the air filters as instructed in the Replacing the Air Filters section on page 12.
	Not enough clearance on all sides of the purifier.	Ensure there is at least 15 inches (38 cm) of clearance on all sides of the purifier.

Problem	Cause	Solution
Poor air purification quality.	Air filters need to be replaced.	Connect the plug to a powered electrical outlet.
	Room is too large for the air purifier's applicable area.	Ensure the room is smaller than 151ft <sup>2</sup> (15 m <sup>2</sup> ).
	Air inlet or outlet is blocked.	Remove objects blocking air inlet or outlet.
Filter reset button is still illuminated after replacing the air filters.	Filters not properly placed in housing.	Properly place filters as noted in the Getting Started and Replacing the Air Filters sections (pages 8 & 12).
	he air purifier has been reset incorrectly.	See the Resetting the Air Purifier section on how to properly reset the unit (page 12).
Air purifier turns on, then suddenly turns off.	Air purifier is defective or malfunctioning.	Immediately discontinue use and contact Customer Support (page 18). DO NOT attempt to open the air purifier for self-servicing.
Air purifier beeps repeatedly after being powered on or plugged in		

# WARRANTY INFORMATION

## TERMS & POLICY

ACEKOOL warrants all products to be of the highest quality in material, craftsmanship, and service, effective starting from the date of purchase.

ACEKOOL will replace any product found to be defective due to manufacturer flaws based on eligibility. Refunds are available within the first 30 days of purchase.

Refunds are only available to the original purchaser of the product. This warranty extends only to personal use and does not extend to any product that has been used for commercial, Rental, or any other use in which the product is not intended for. There are no warranties other than the warranties expressly set forth with each product. This warranty is non-transferrable.

ACEKOOL is not responsible in any way for any damages, losses or inconveniences caused by equipment failure or by user negligence, abuse, or use noncompliant with the user manual or any additional safety, use, or warnings included in the product packaging and manual.

This warranty does not apply to the following:

- Damage due to abuse, accident, alteration, misuse, tampering or vandalism.
- Improper or inadequate maintenance.
- Damage in return transit.
- Unsupervised use by children under 18 years of age.

## Defective Products & Returns

Should your product prove defective within the specified warranty period, please contact Customer Support via **support@acekool.vip** with your invoice and order number. Once our Customer Support team has approved your request, please return the unit with a copy of your invoice and order number.

## CUSTOMER SUPPORT

Should you encounter any issues or have any questions regarding your new product, feel free to contact our helpful Customer Support Team. Your satisfaction is our goal!

## CUSTOMER SUPPORT

Email: [support@acekool.vip](mailto:support@acekool.vip)

\*Please have your order invoice or order number ready before contacting Customer Support.