

ORTUR

LASER MASTER 3



THANK YOU!

Dear friends,

Thanks for purchasing the Ortur Laser Master 3 laser engraver. We really appreciate your recognition and hope you like it.

ORTUR is a company specialized in manufacturing and researching laser engraving machines since 2018. ORTUR is sold all over the world, occupying a leading position in the industry.

Ortur is trying to satisfy people's needs for creation. Ortur commits ourselves to making creation easier for every individual. Creativity is what distinguishes human beings from other creatures. We believe every individual has the intention to create. That's why there are so many powerful and handy tools with easy access and systematic tutorials.

But the fact is, the tools for creation have not evolved ever since people began to use knives and scissors hundreds of years ago. So Ortur is trying to create engraving and cutting tools to replace the much less powerful knives and scissors, by making the most of laser and software technology. These Laser engravers totally facilitate the creation and make it more enjoyable than ever.

ORTUR's mission is to make laser engraving machines safer, and faster and make creation easier. Help you to grow your businesses.

If you have any questions, please feel free to contact us immediately.

You can join our Facebook group, which brings innovators like you together to share your ideas and get inspired by others.

Thank you again for your support.

Customer support Email: support@ortur3d.com



Content

A	Package Contents	1
B	Disclaimer and Safety Guidelines	2
C	Install the Machine	3
D	Ports and Buttons	16
E	How to Use the Buttons	17
F	Main Power Button Indicator Instructions	17
G	Check the Machine	18
H	Quick Start	19
I	Adjust Wheels and Timing Belt	24
J	Questions and Answers	27

Link ai manuali di lingua italiana | Enlaces al manual en español | Linki do podręczników języka polskiego |
Ссылки на руководство на русском языке | Links para manuais em língua portuguesa | قی برعلا تابیتكلا طباور

<https://ortur.tech/olm3/>



A Package Contents



Front Integrated Part



Rear Integrated Part



X-axis Integrated Part



M3*6mm Screw



WIFI Aerial



Laser Wire



Wrench



Testing Wood



Laser Goggle



Power Adapter



Cable Tie



Y-axis Left Part



Y-axis Right Part



Main Wire



M4 Set Screw



Timing Belt

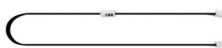

YRR Adapter Wire



2 & 2.5 & 3mm Allen key



Testing Acrylic



USB Cable



Power Cable



Brush



M4*8mm Screw



Idler Gear Part



Testing Aluminium Flake



Machine Key



Card Reader + TF Card

The picture is for reference only, please refer to the real thing!

B Disclaimer and Safety Guidelines

01. The laser engraver could generate laser light. It is strictly forbidden to place any living body under the laser emission port (this port is marked with a yellow warning sign).
02. Patients with photosensitive epilepsy are prohibited from using or approaching the laser device.
03. When using the laser engraving machine, the operator and anyone near the machine must wear laser safety glasses.
Do not operate the laser without glasses protection (laser goggles).
Our machines come with a pair of safety goggles, but additional laser safety glasses can be purchased commercially.
Requirements for goggles: wavelength protection 400-445nm (+-5nm), outer diameter +5, minimum L-level L5.
04. When the laser engraver is working, the operator must pay close attention and not place it alone to prevent the engraved material from catching fire.
Please set up the laser engraver in a fireproof area and ensure good ventilation.
If possible, we recommend that you purchase a fire extinguisher and keep it close to the machine.
05. Using the laser engraver in a room that can be closed by a door, making sure that neither the laser beam nor stray light can penetrate the window.
06. When using the laser engraver, put the door sign or the warning light on the door to indicate that the laser engraver is running.
07. Make sure there is no flammable material near the laser engraver, we recommend put a fireproof mat under the machine.
08. Ensure adequate environment when operating the laser engraving. Engraving certain materials may generate fumes, which should be exhausted by a dedicated filtered exhaust.
09. When the machine is running, do not touch the laser beam or touch it with other objects, which may cause serious bodily injury or beam reflection.
Do not touch the radiator, you may burn your body and hands when the laser engraver just stops working.
10. Do not let children or teenagers use the laser engraver alone (especially children under the age of 14), adult supervision is required at all times.
11. For commercial use, using and registering with regulatory authorities and professional associations is mandatory.
12. The operating temperature range of the machine is -15°C ~ 30°C.
13. There would be a high risk of fire, when the laser irradiates the engraved object. If the laser engraver is working, it must be taken care of at all times by the skilled operator, who knows how to use a fire extinguisher, so that any unexpected situations could be dealt with in time.

Install the Machine

1)

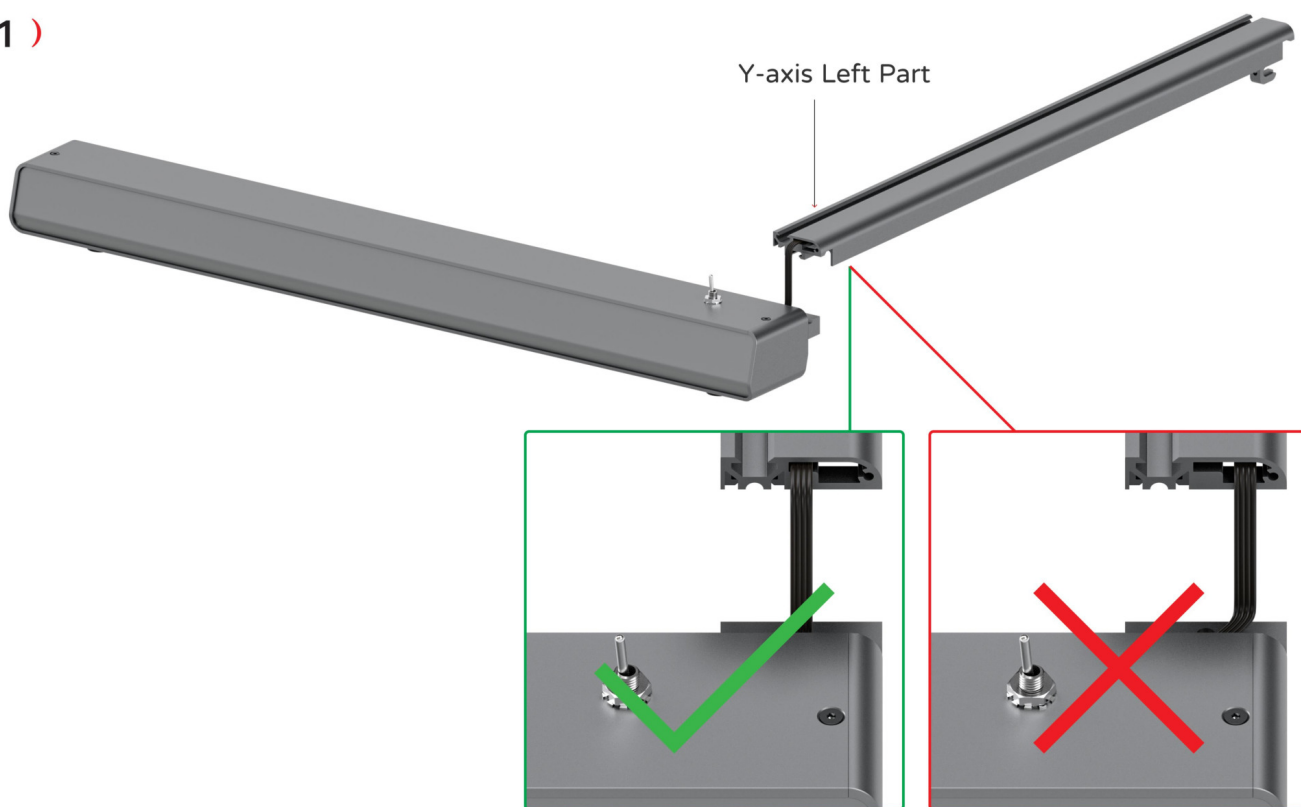

Please place the wire correctly, otherwise it will be damaged!

2)

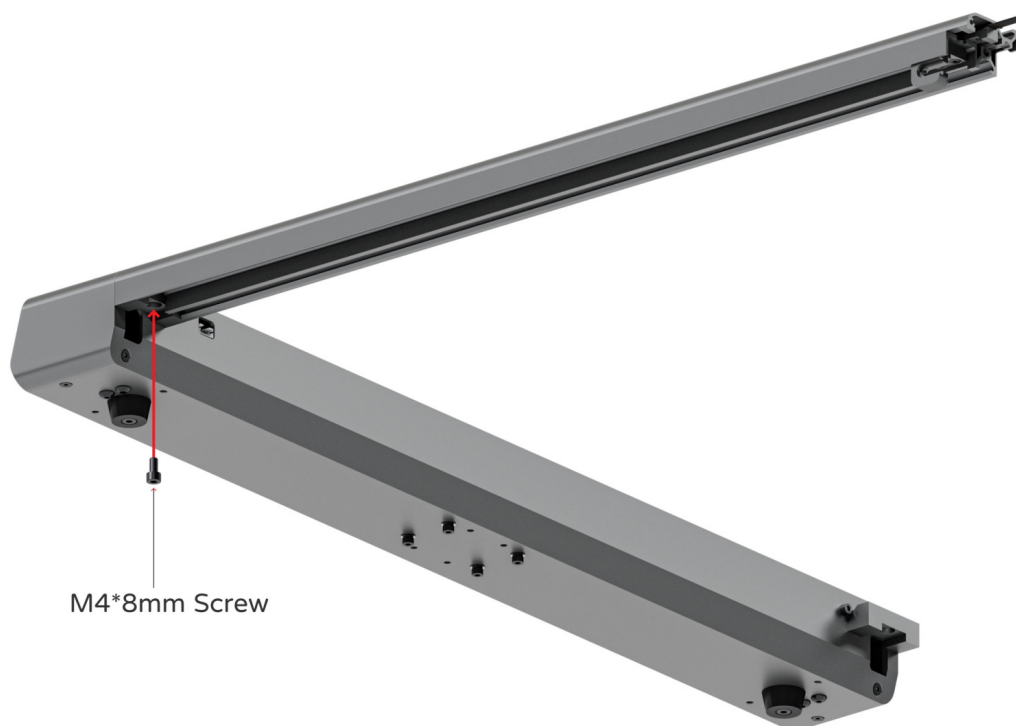

3)

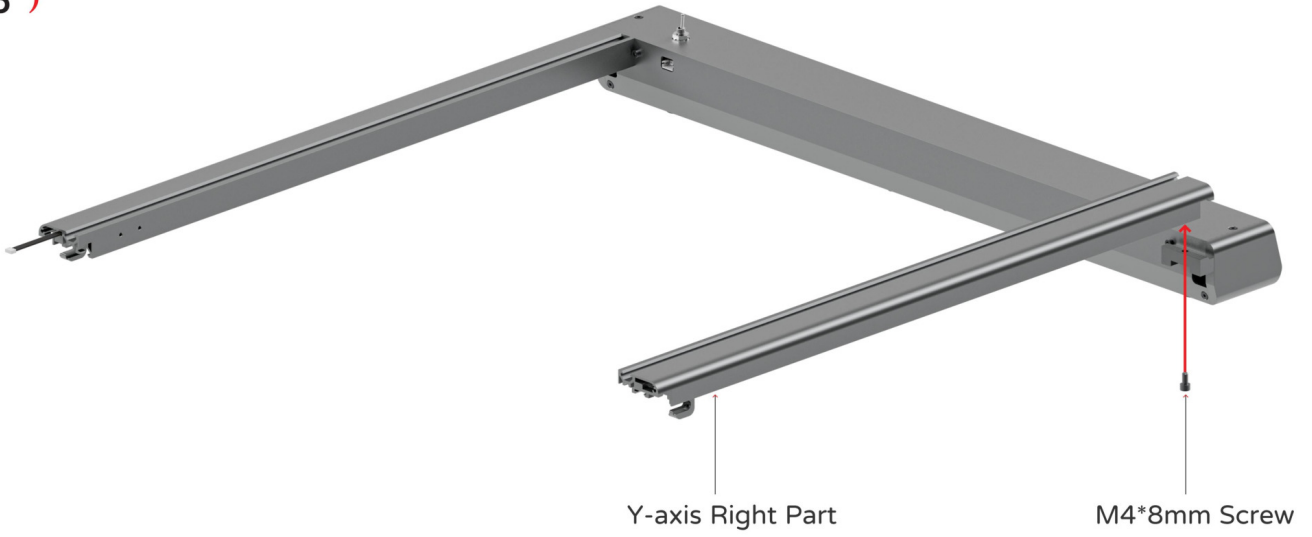

4)

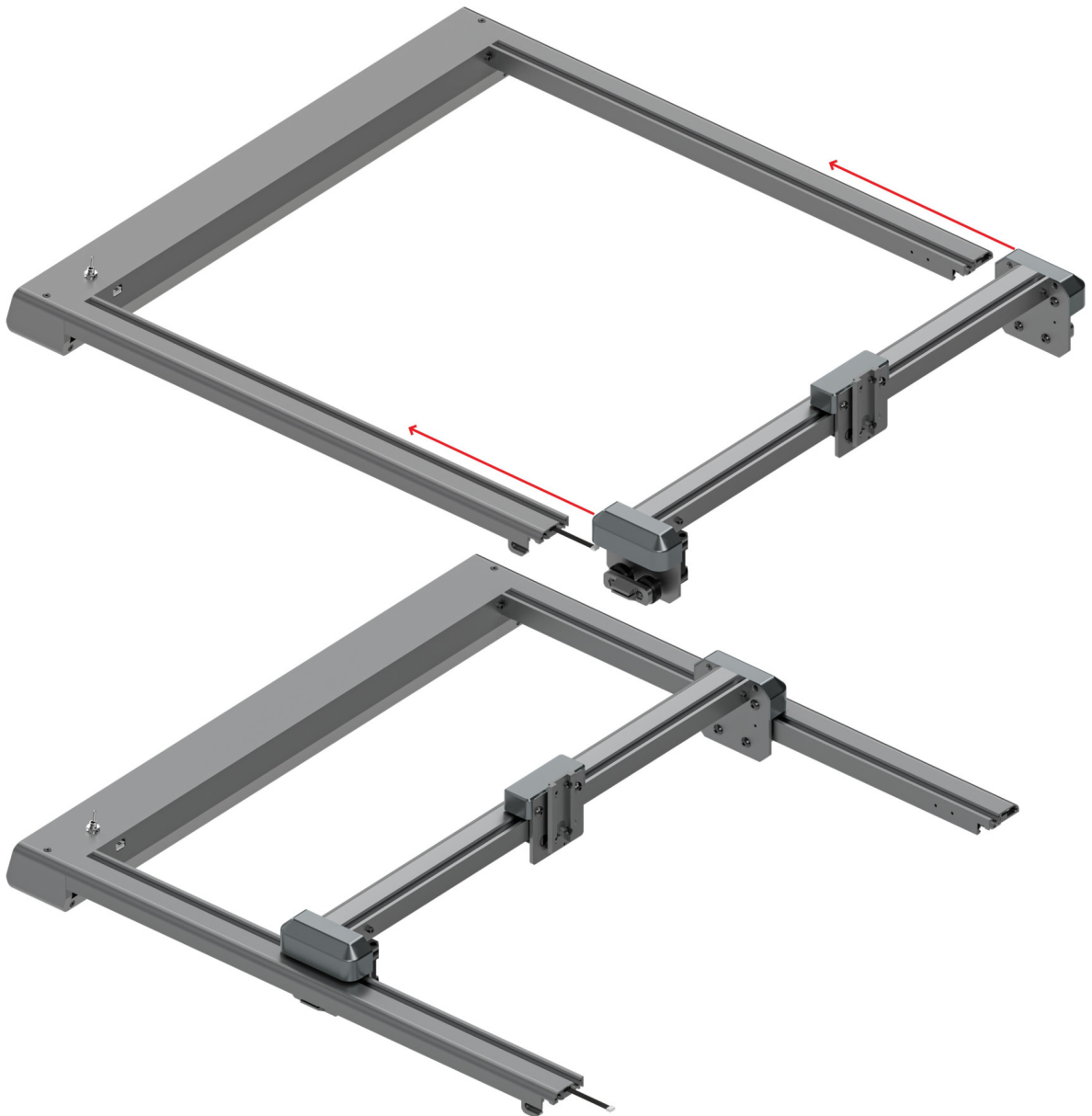

5)

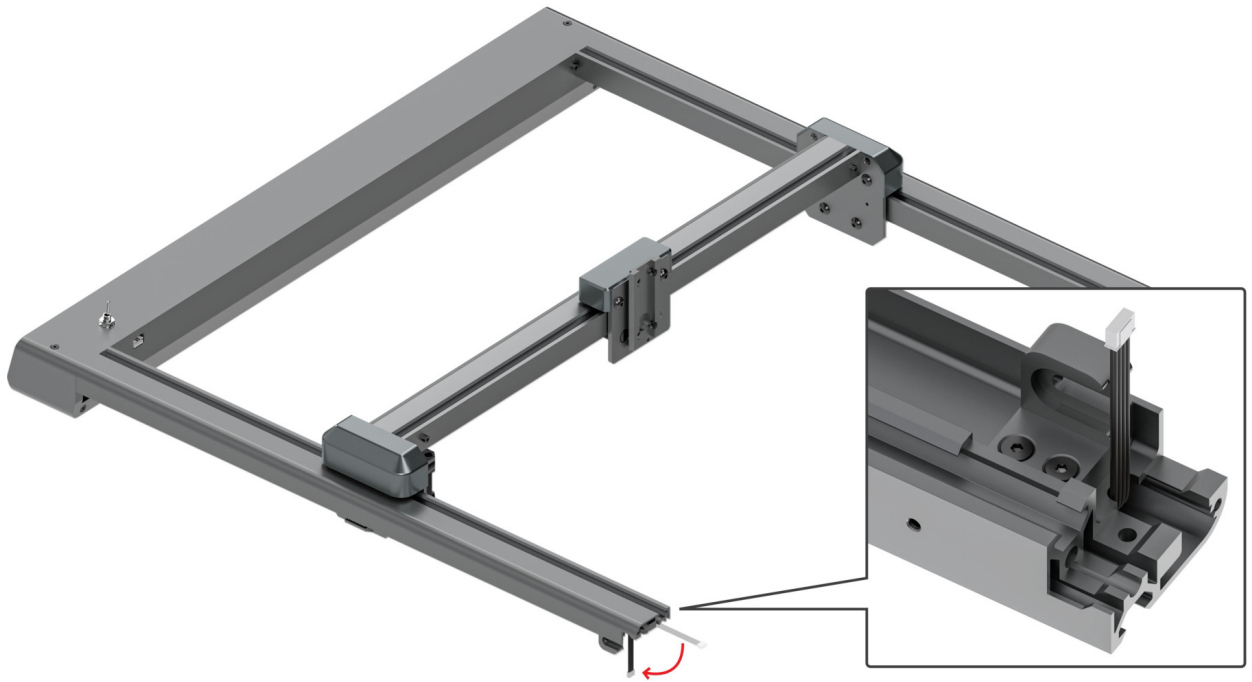

Please bend the wire like the picture.

6)

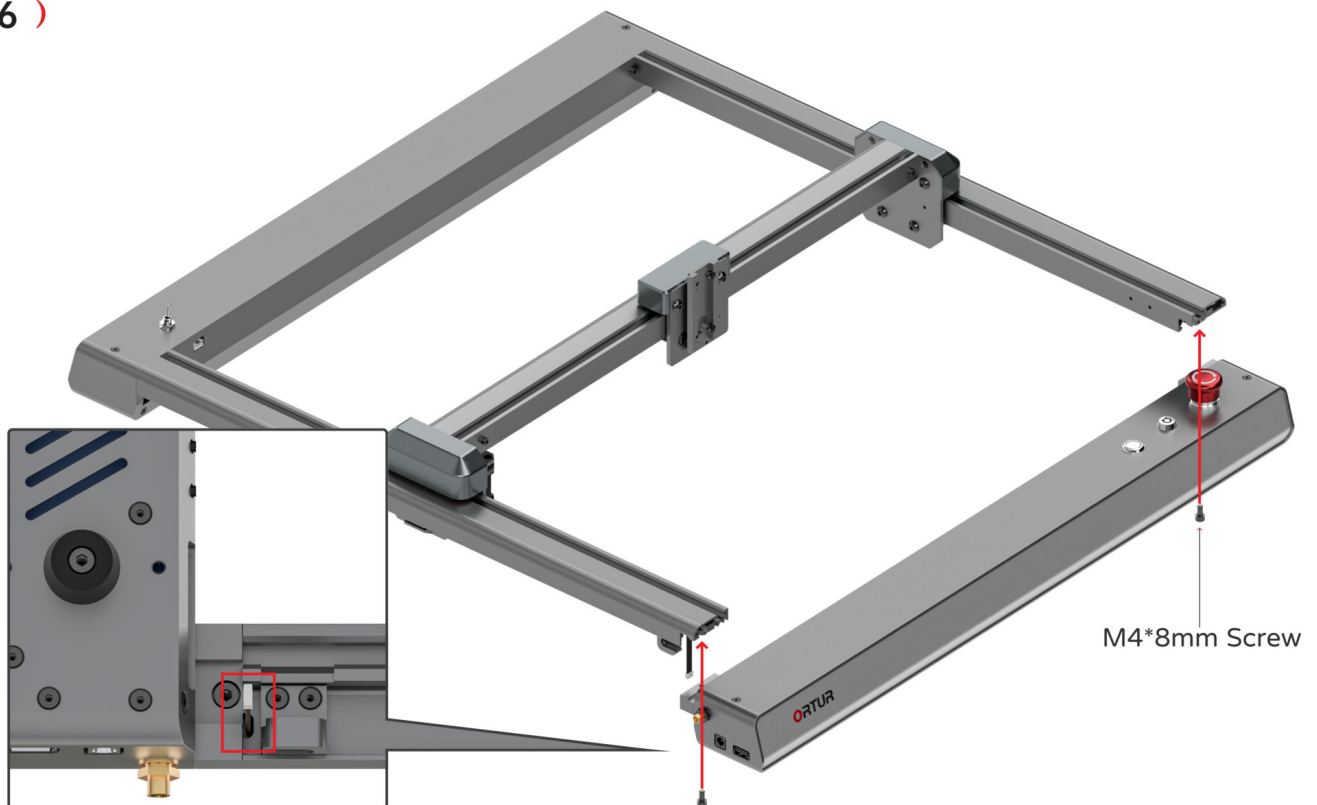

Please ensure that the wire stay in the gap, always pay attention to its location!

7)

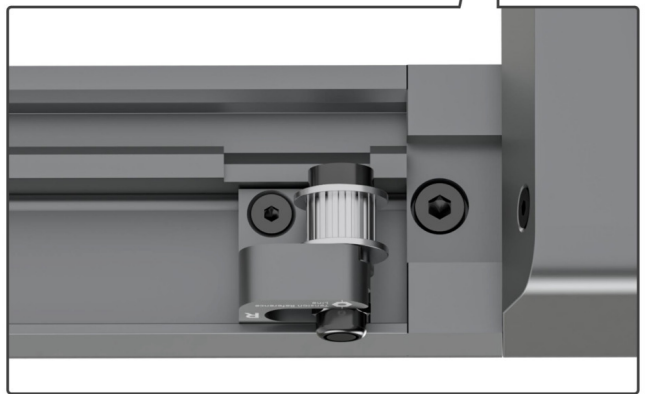
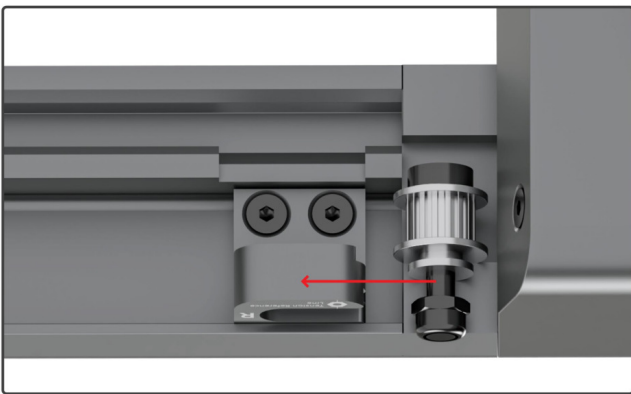
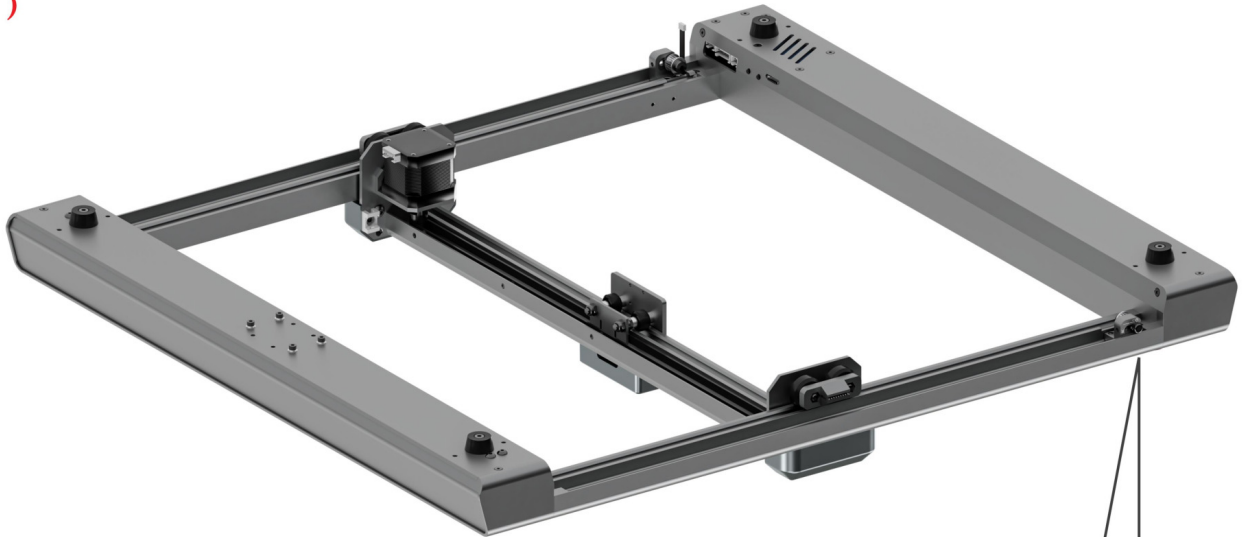

Use allen key to fix this part, but don't tighten it! After that, it needs it to move left and right.

8)

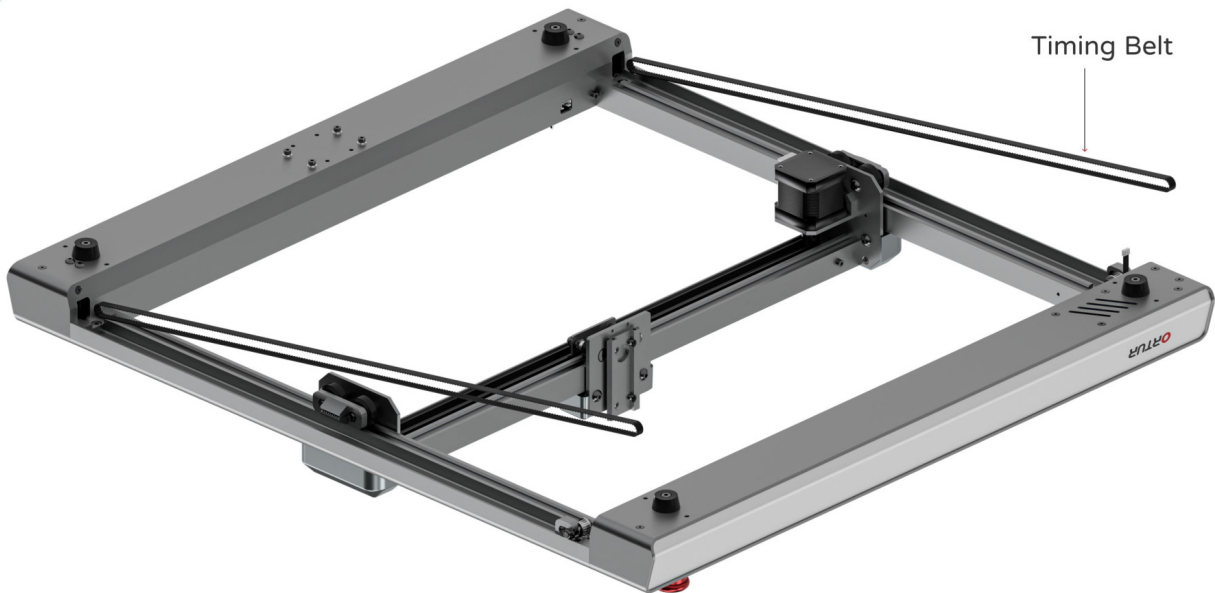

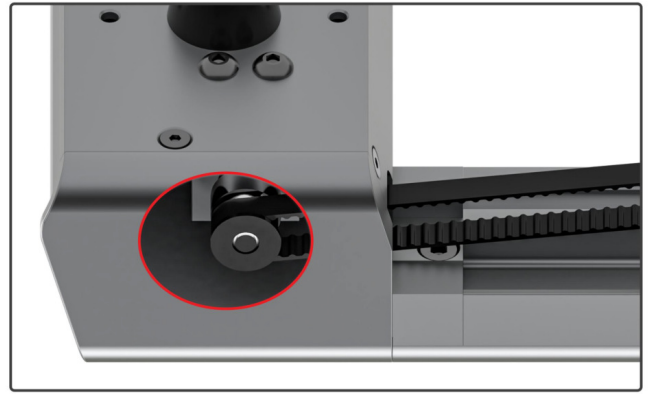
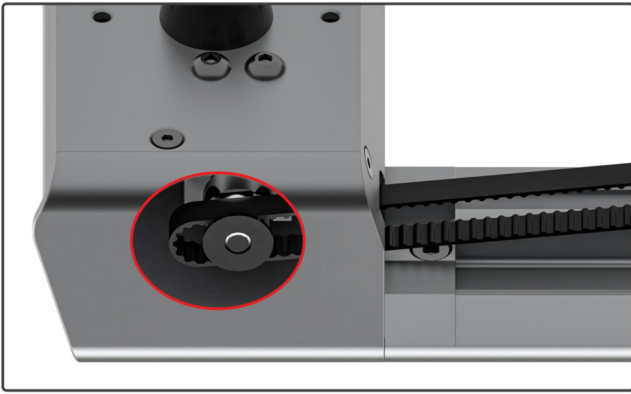

Put the positive timing belt on the black parts. Do the same on the other side.

9)

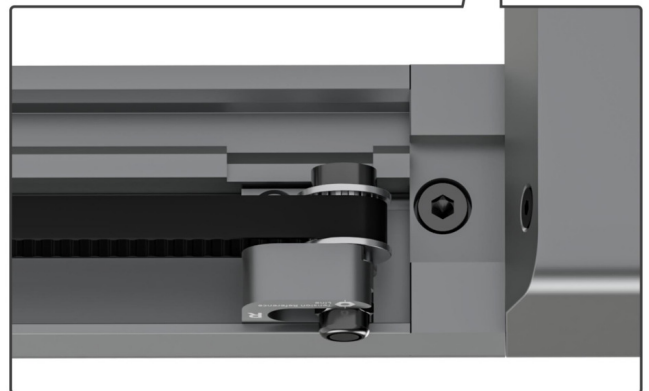
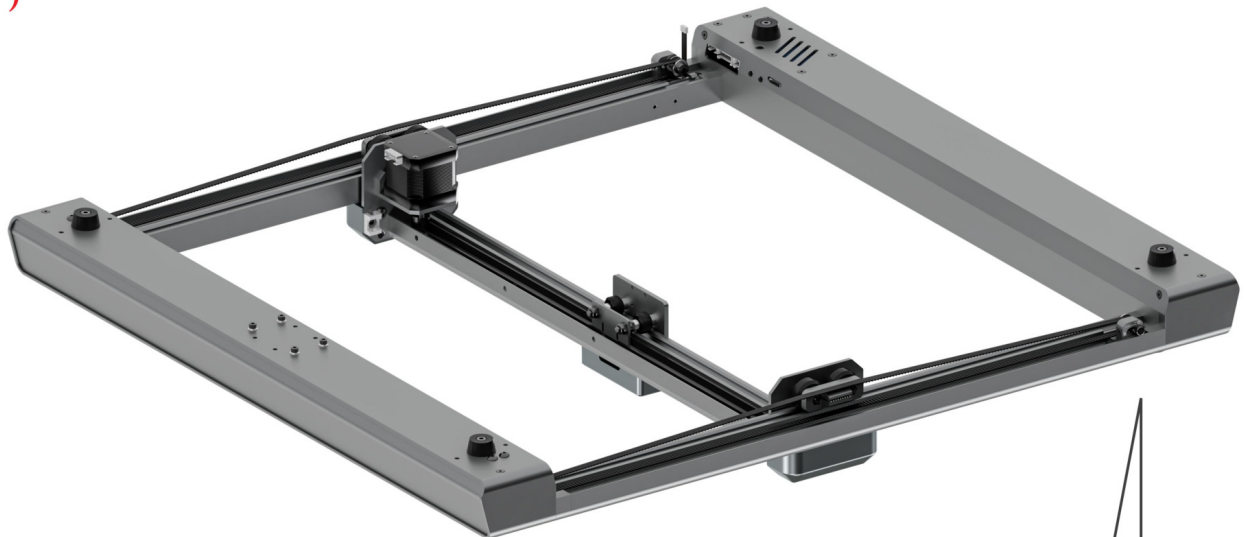

Put the other side of timing belt and set it on the parts installed in step 7. Please note that timing belt should not enter the clip, look at the left picture!

10)

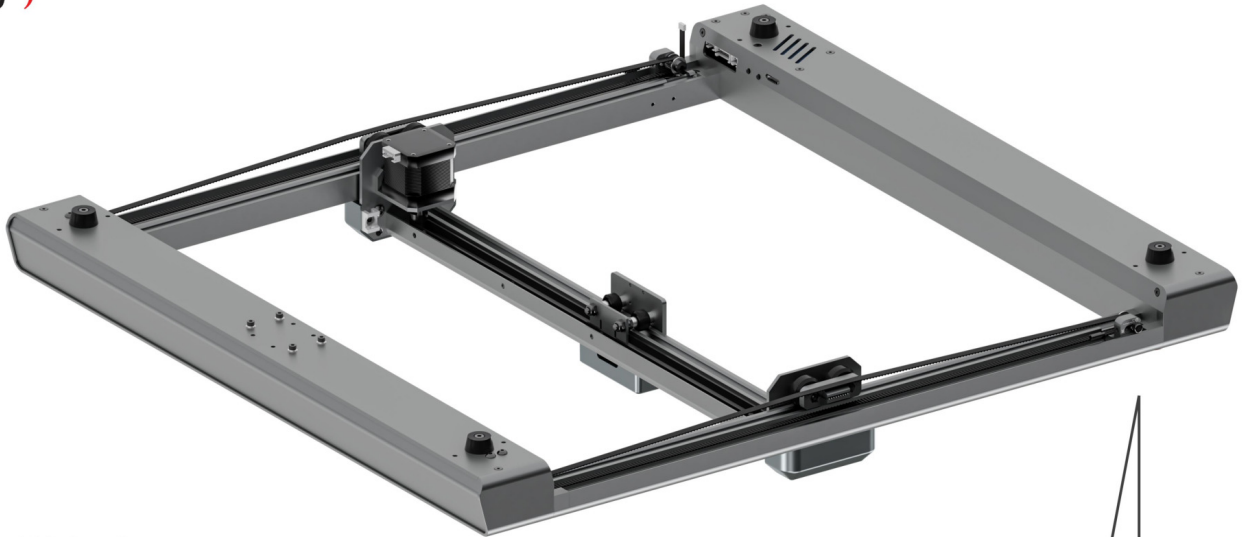

M4 Set Screw

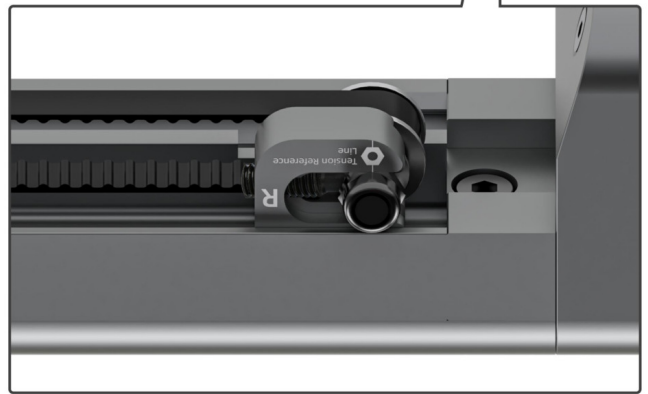
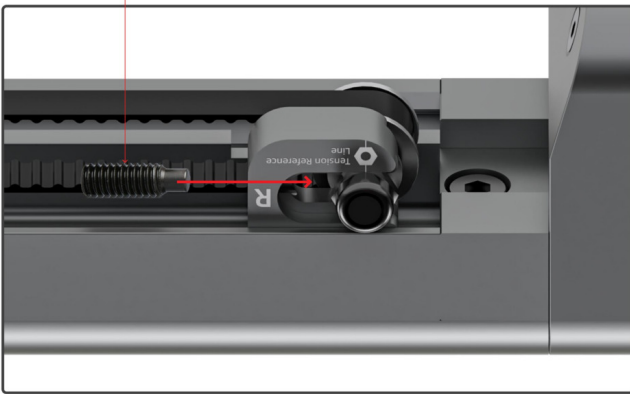

Install the set screws, no need to tighten at this time!

11)

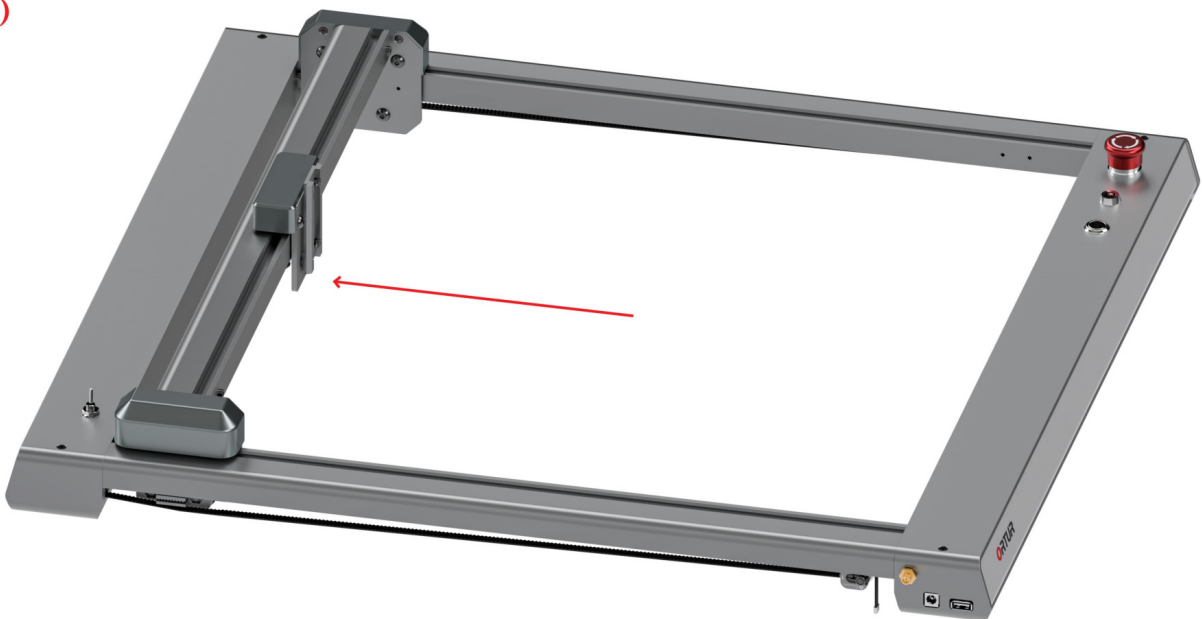

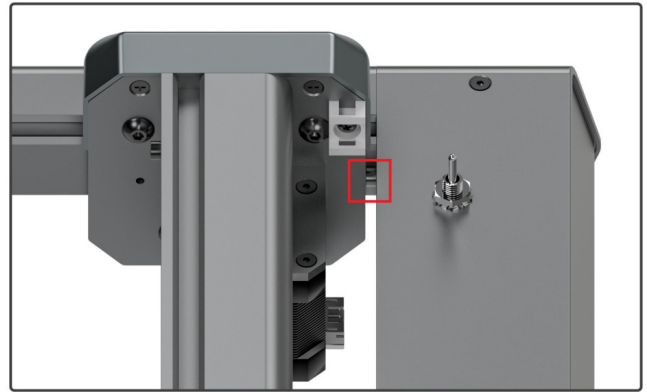
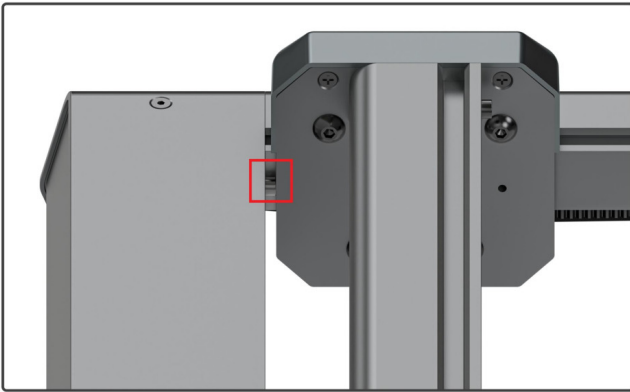

Push the X-axis back, making sure that both sides hit the limit screws and that there is no gap between them.

12)

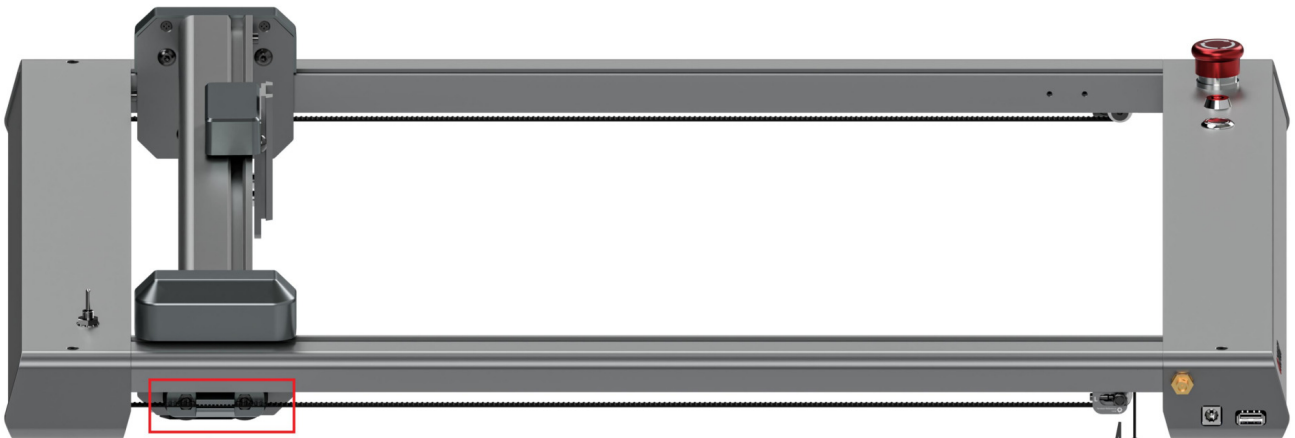

Let timing belt enter the clip, and ensure that the X-axis does not move!

The position of the white "I" is the best position for the tension of the timing belt.

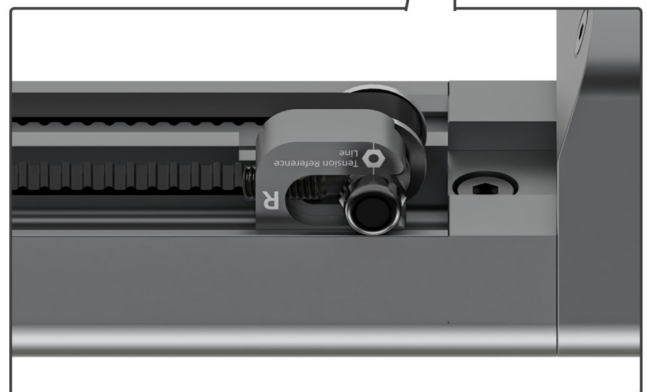

Adjust the screw until the part moves to the center of the white "I" mark, and then tighten them!

13)

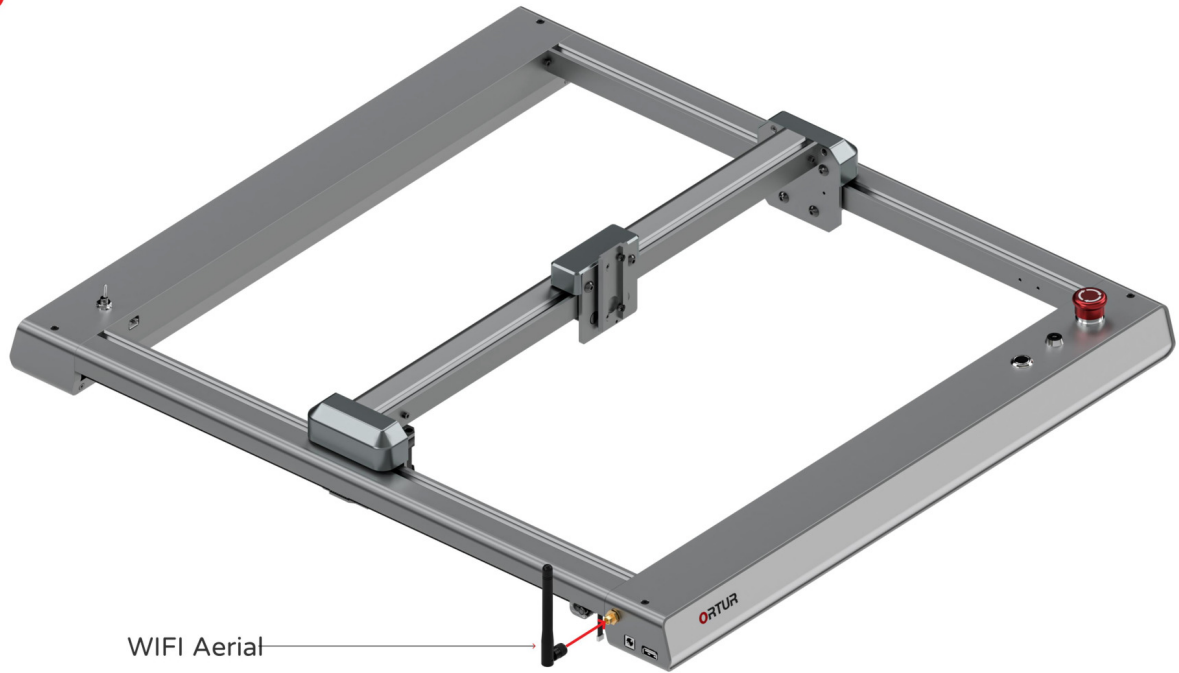

14)

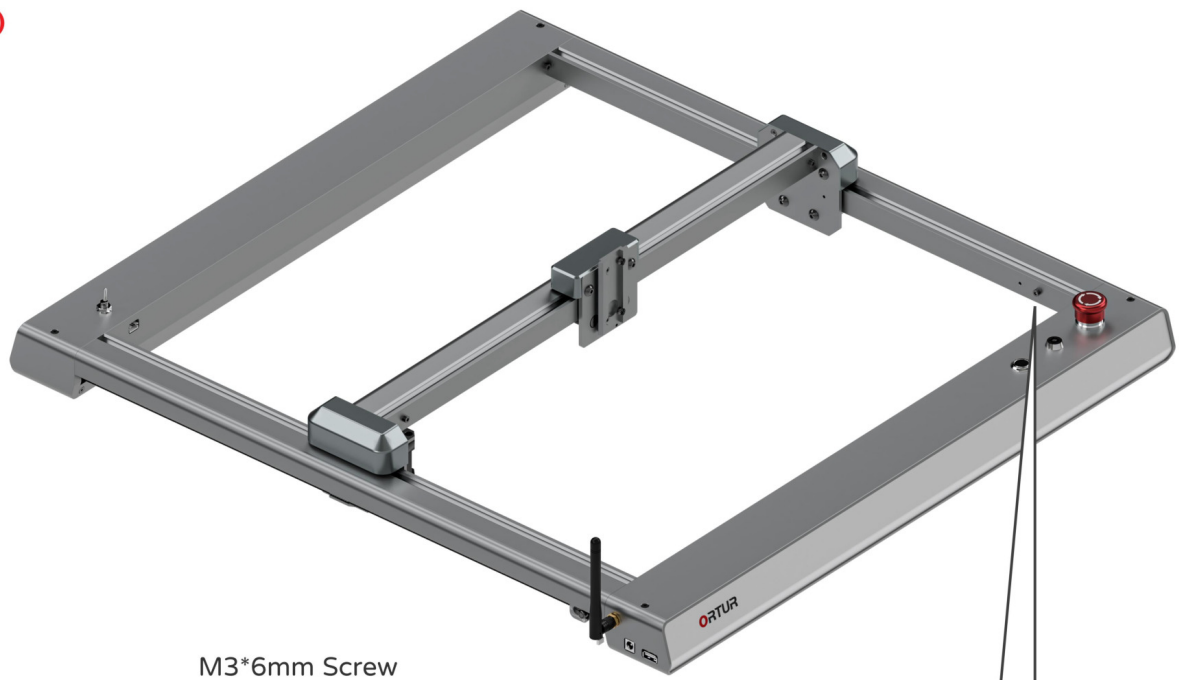

M3*6mm Screw

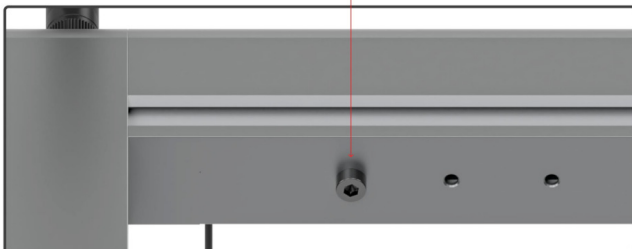

The distance between the two screw holes is 20mm, so every time the screw is moved back, it will result in a 20mm reduction in the Y-axis engraving area of the machine. Please adjust the hole position for screw installation according to the laser module to ensure that the laser module does not collide with the Front Integrated Part.

15)

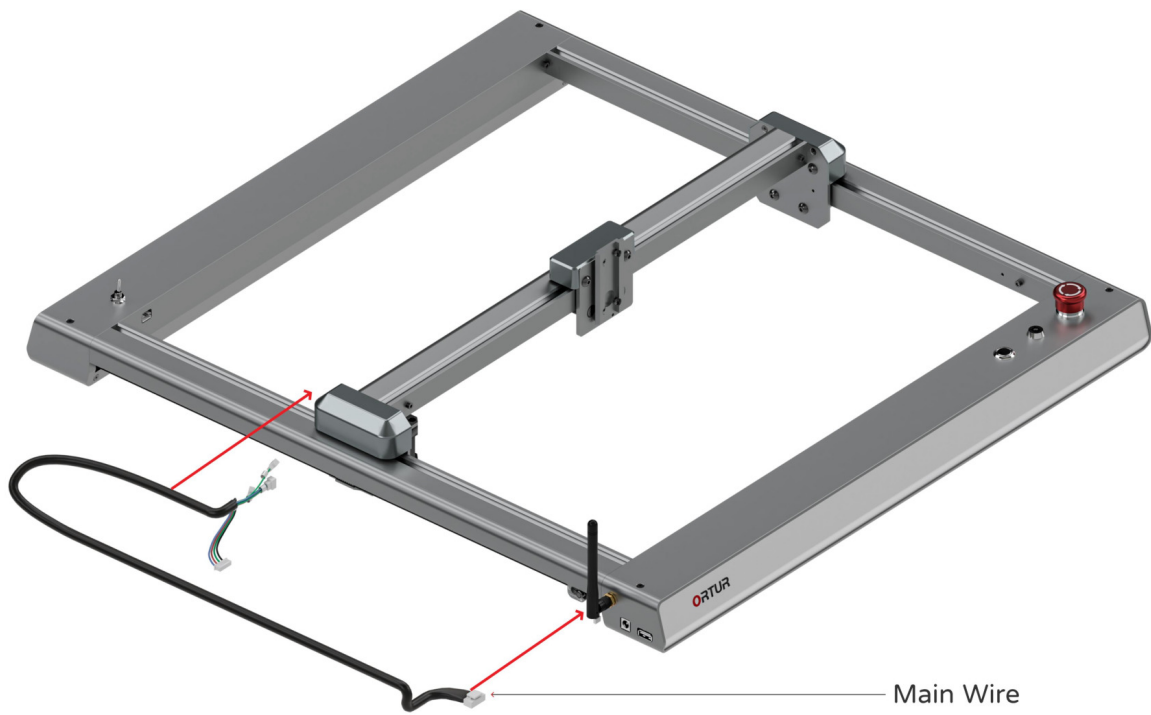

16)

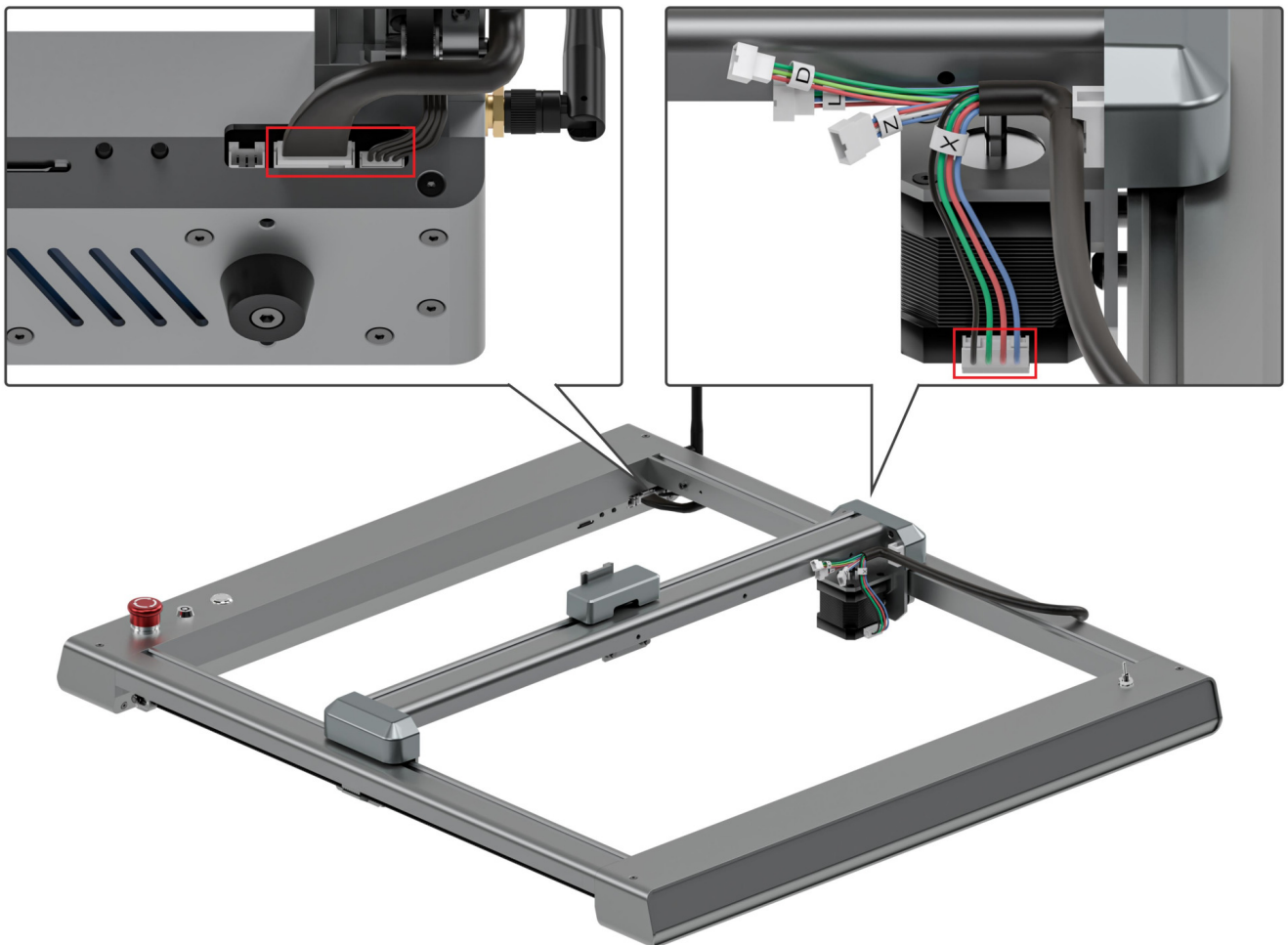

According to the picture, insert the wire into the corresponding port.

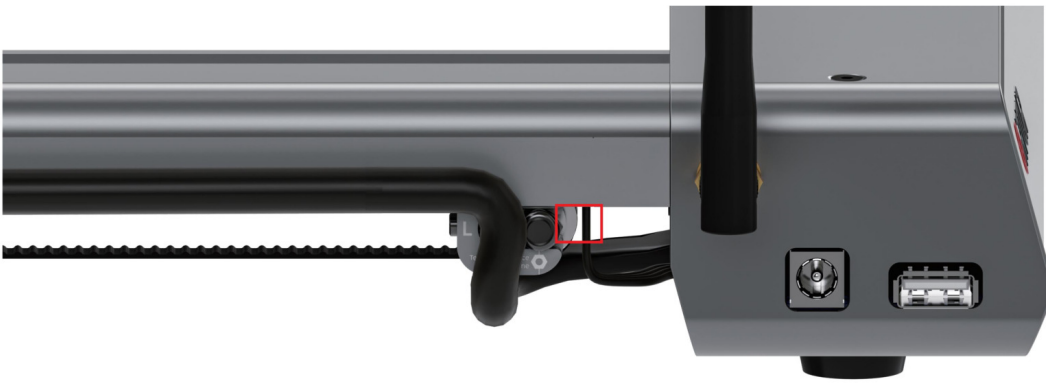

Pay attention to the parts and wire in the red box, they must keep the distance!

17)

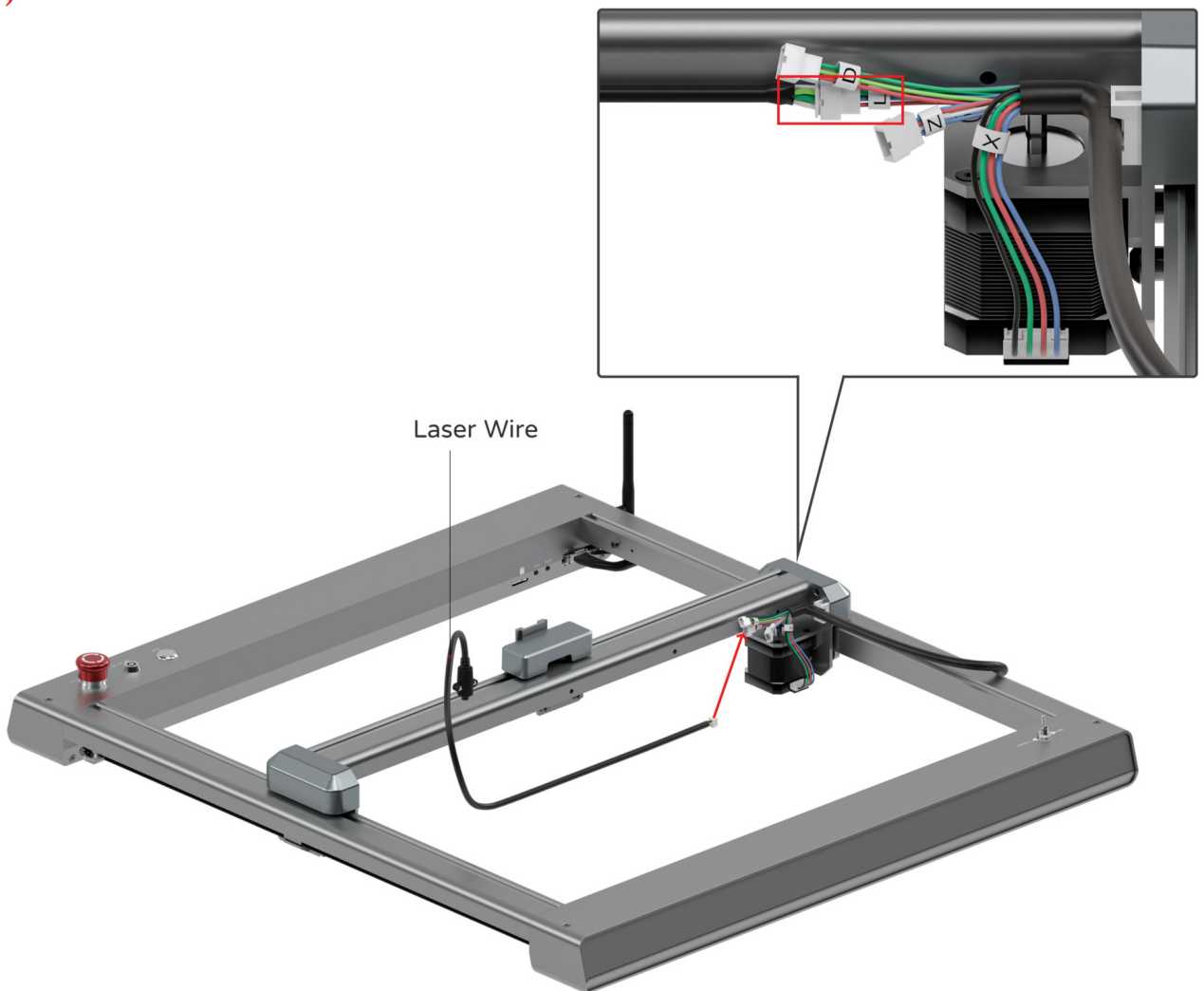

Couple the laser wire to the port with the "L" label.

18)

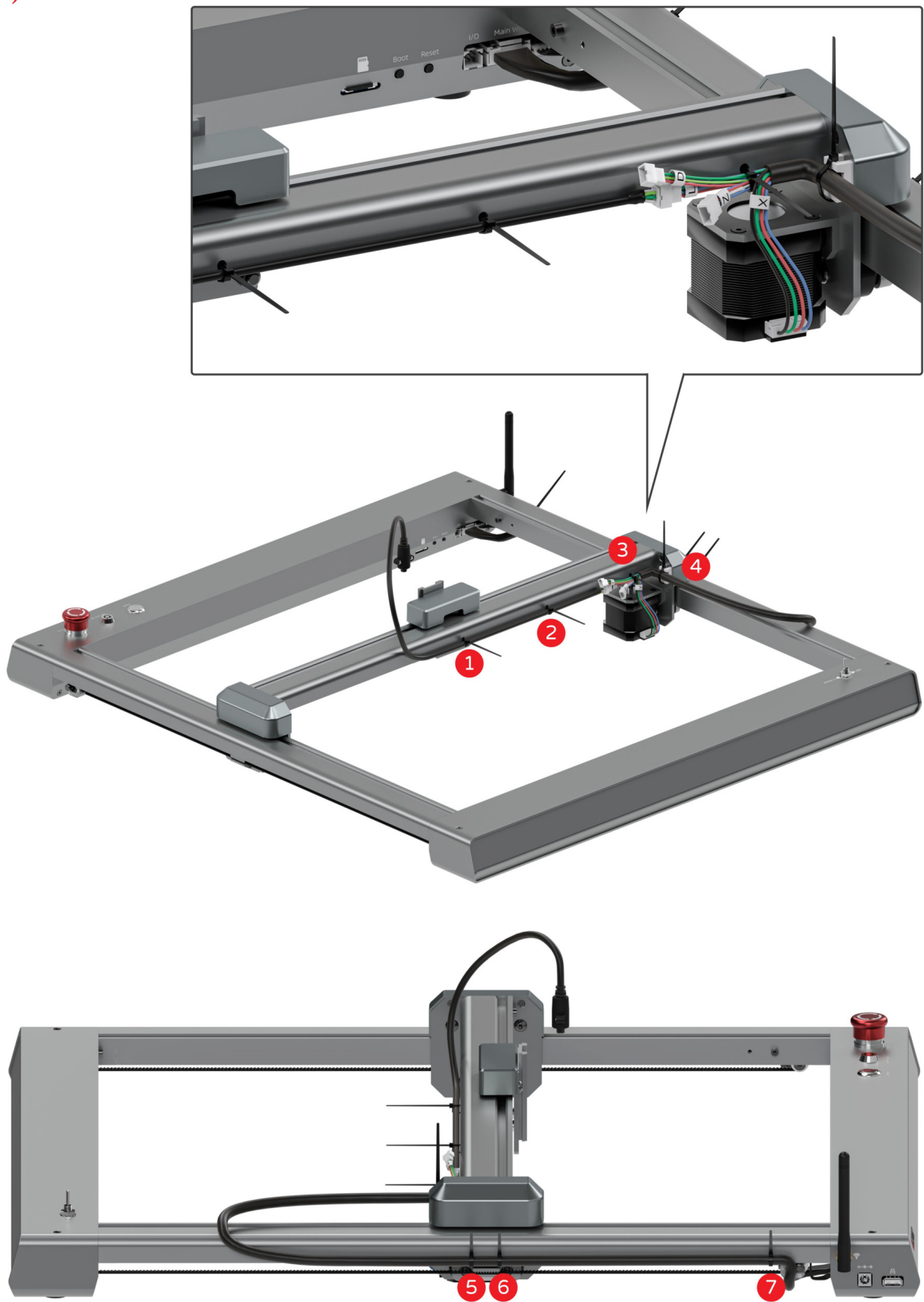

Bind the wires at the label position.

19)

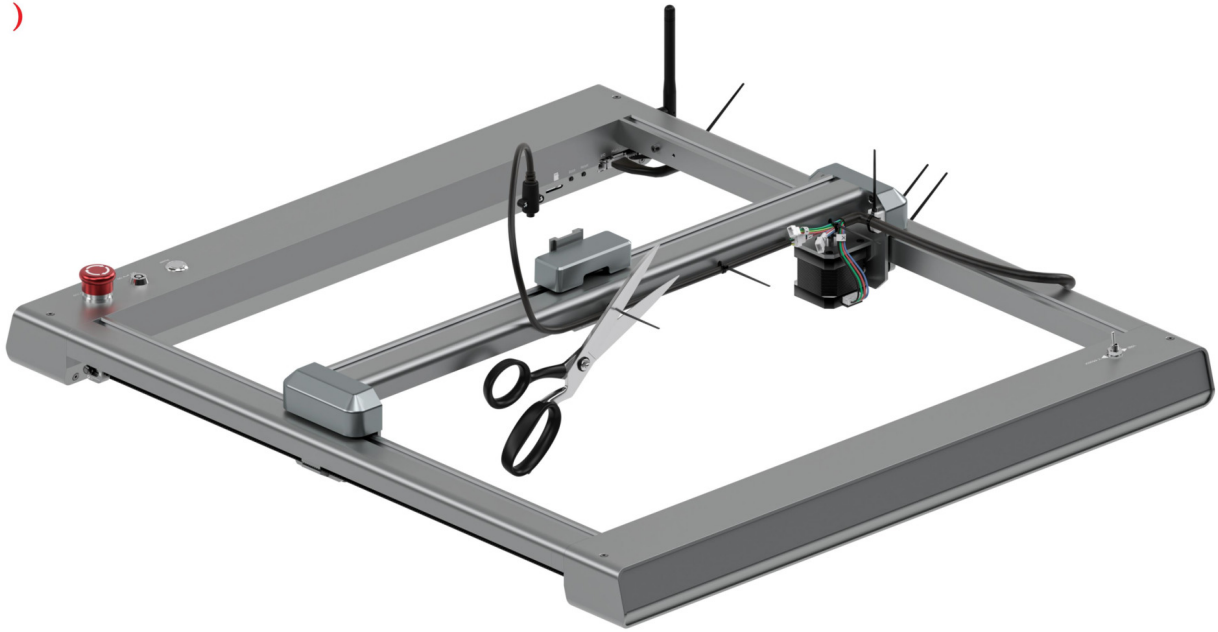

Cut off the excess part of the cable tie with scissors.
(Scissors need to be prepared by yourself)

20) The laser module has an independent manual!

Understand Your Machine

D Ports and Buttons



① Interface of WIFI

② Power Input

③ Interface of USB

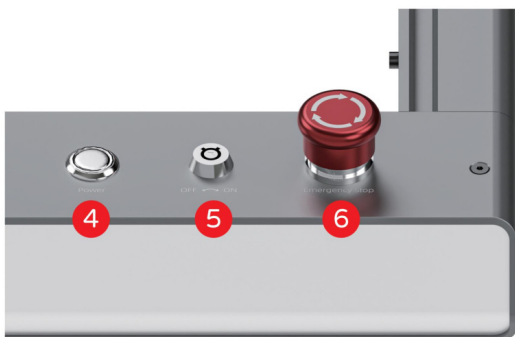

④ Main Power Button (Status Light)

⑥ Emergency Stop Button

⑧ Restore Button

⑩ Expand Interface

⑫ Interface of Y-axis Motor Wire

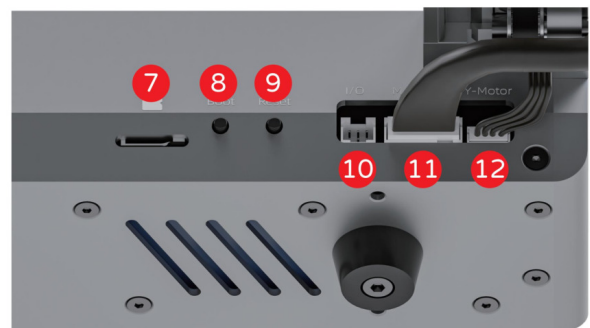

⑤ Key Switch (Child Lock)

⑦ TF-card Slot

⑨ Reset Button

⑪ Interface of Main Wire

⑬ YRR Switch



⑭ Interface of YRR Adapter Wire

If connecting YRR or YRC, switch to "YRR".

E How to Use the Buttons

Destination	Conditions for Execution	Change of Light	Execute Action
Boot	In the shutdown state, press and hold the power button for more than 500 milliseconds	White from dark to light	The machine starts and returns to homing
Shutdown	Under power-on status, press and hold the power button for more than 500 milliseconds	White from light to dark	The machine shuts down and the light goes out
Upgrade Mode	In the shutdown state, press and hold the power key while pressing the Reset	Flashing red, green and blue alternately	USB flash drive appears on the computer
Reset the Motherboard	Short press the Reset	Lights off	The machine shuts down and the light goes out

F Main Power Button Indicator Instructions

Major State	Substate	Effect	Remarks
When Booting		White from dark to light gradient time 1500ms	Long press > 500ms
When Shut Down		White light to dark gradient time 3000ms	Long press > 500ms
Booting Initialization		White Flashing for 250ms	
Upgrade Mode		Red, green and blue are flashing alternately at 333ms	
In the Upgrade		Red, green and blue are flashing alternately for 100ms	
Update Success		Green is always bright	Automatic restart for 500ms
Upgrade Failed		Red often bright	Automatic restart for 1000ms
SmartConfig Pattern		7 Color gradient	In the power-on state, please press the power button for 5 times 50ms <Click <200ms
Jog State		Blue flashing 250ms	
Homing State		Blue flashing 250ms	
Sleep State		White breathing light Cycle 200ms	
Emergency Stop State		Red and yellow flicker alternately for 250ms	
Power Lock Status		Red is 25% brightness	Power lock off, not on, showing 25% red when the power key is pressed
IDLE State		Green is always bright	5000ms, after showing substatus
IDLE Substate	WIFI Connection	In WIFI STA connections, orange, flashing, 4 times, 250ms	Display is only shown as in the IDLE state
	WIFI Success	WIFI STA has been connected, orange, bright, 1000ms	
	USB Cable Joint	The USB has been connected, light blue, bright, 500ms	
	AP Connected Status	WIFI AP has been connected, purple, bright, 1000ms	
RUN State		Green flashing 250ms	
HOLD State		Cyan often bright	
Alarm State		Yellow often bright	
System Error		Red, often bright, can be superimposed sub-error	3000ms, after showing substatus
System Error Substate	Motor Drive Error	Blue-2 times	Display only in the error state
	Voltage Abnormal Error	Purple-3 times	
SD-card Initialization Error		Yellow and white flicker intermittently alternately	

6 Check the Machine

1)

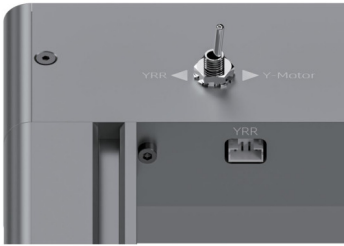

Point the YRR switch to the side of the "Y-Motor" logo.

2)

Turn the key switch on with the machine key. Make sure the emergency stop button is pressed.

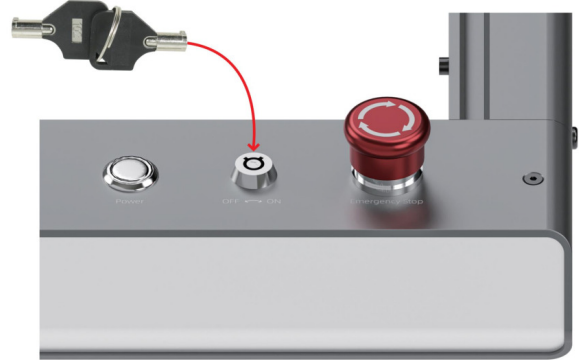

3)

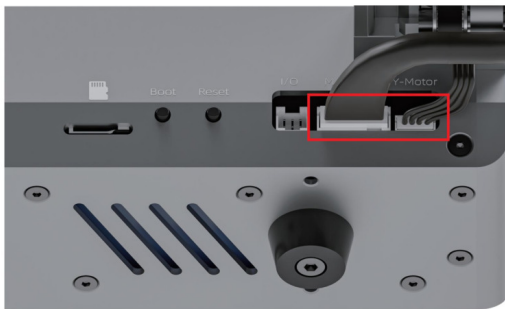

Make sure the wires is fully plugged into the port!

4)

Move the X-axis up and down, left and right, making sure the wheels are moving without problems.

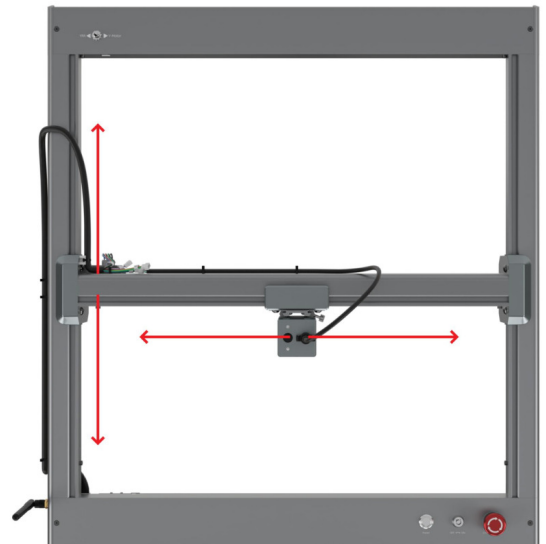

5)

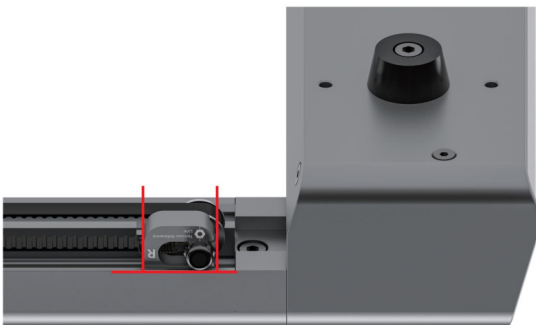

Make sure the idler gear part bracket is perpendicular to the slide rail!

H Quick Start

1)

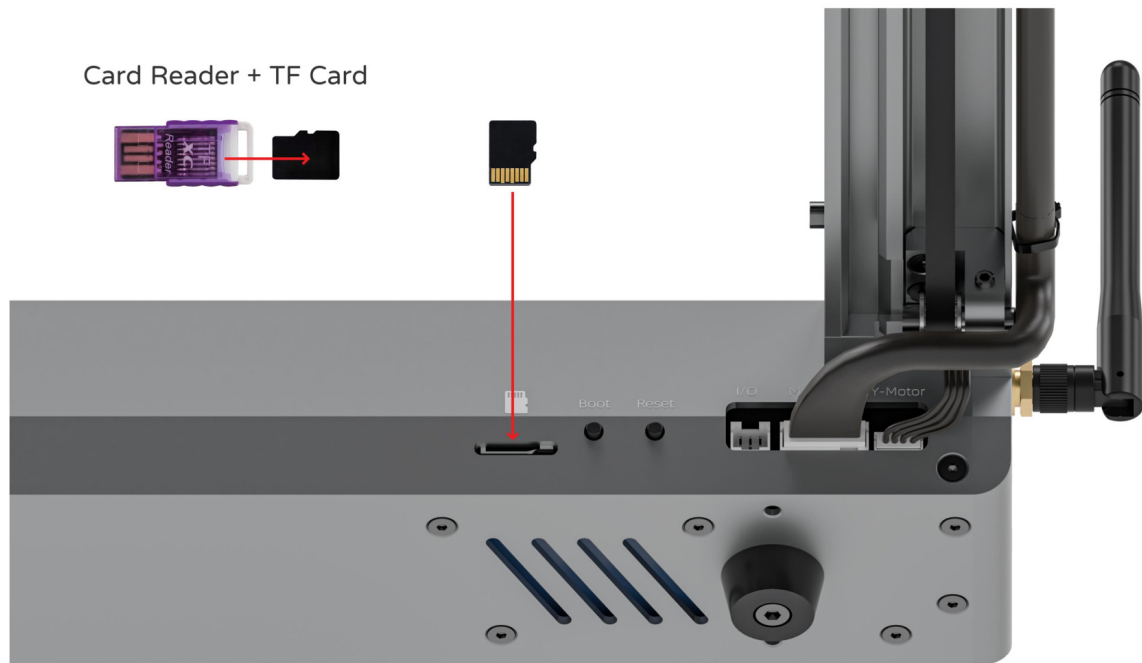

Before the machine boots, insert the TF card in the card reader into the corresponding card slot of the machine. (Don't use force to insert cards. Card insertion is necessary!)

2) Download the APP



Laser Explorer is a free and professional mobile software that supports Android Phone, Tablets, iPhone and iPad.

3)

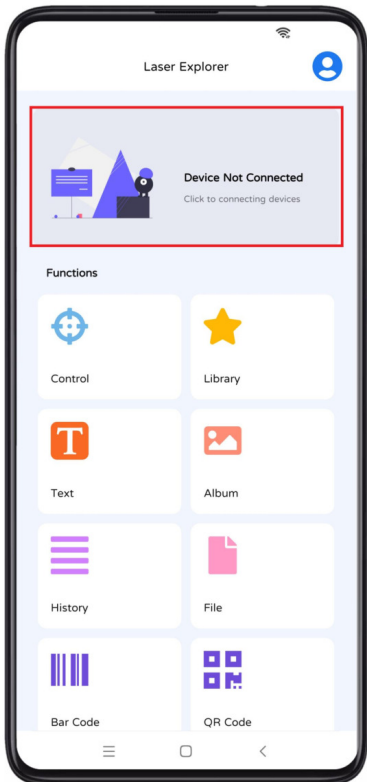

Please connect the machine under the 2.4G WIFI network and turn off the dual-band WIFI function of the mobile phone!

The distance between mobile phone and machine is recommended to be within 5 meters. Try to get close to them if possible.

4)

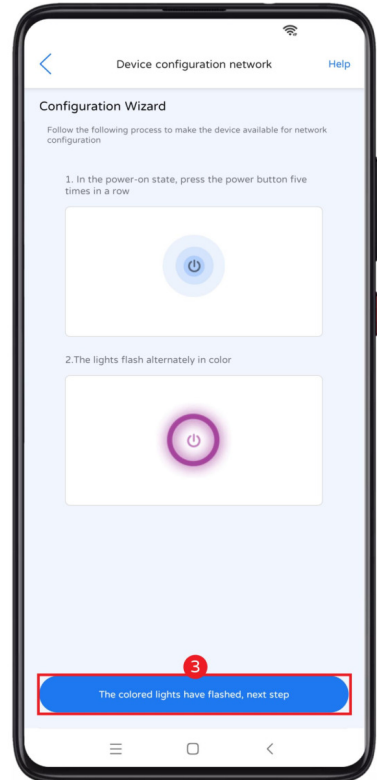
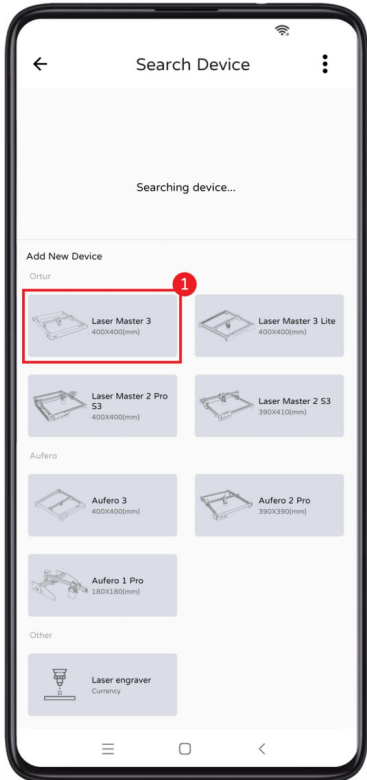

Select the corresponding machine type and enter the password for the wifi on the jump page. Press the power button five times in the boot mode. The device enters the network distribution pattern and lights flashing and clicks on the next step.

5)

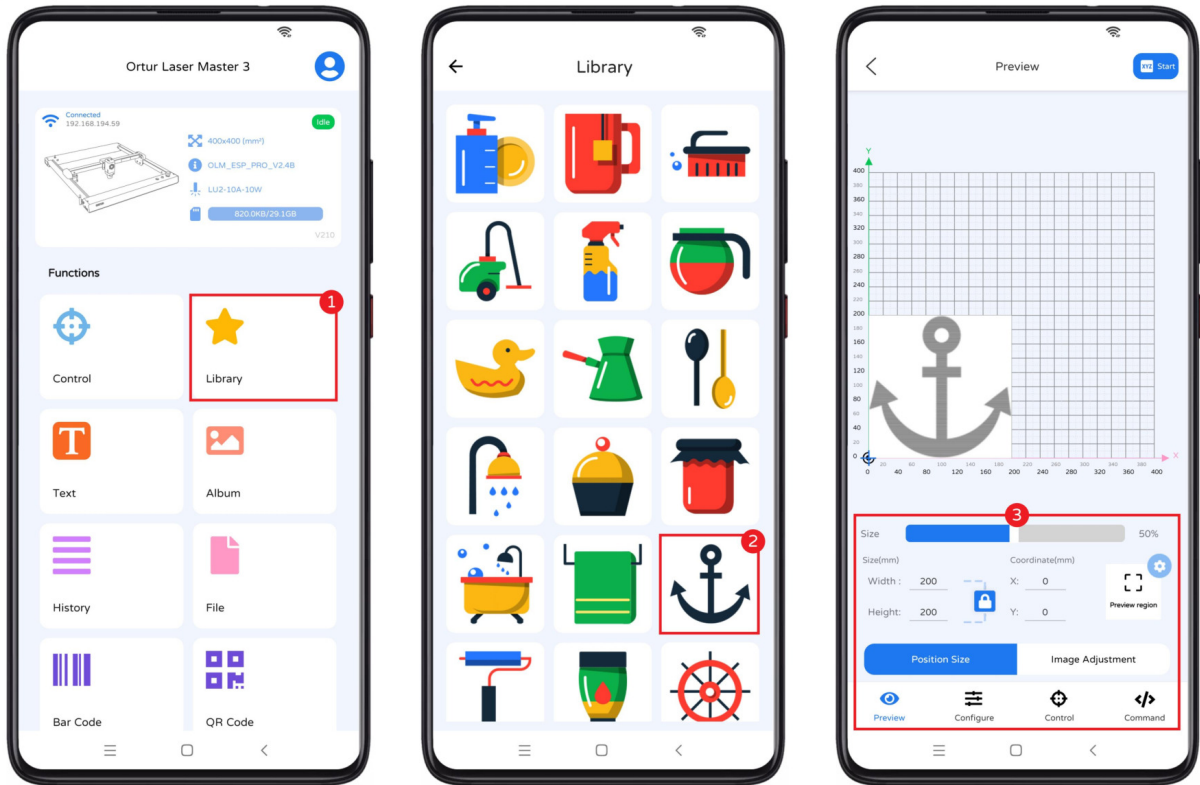

You use a picture from the library or an album, and of course you can take a picture and use it! On the preview page, you can adjust the Settings of the image.

6)

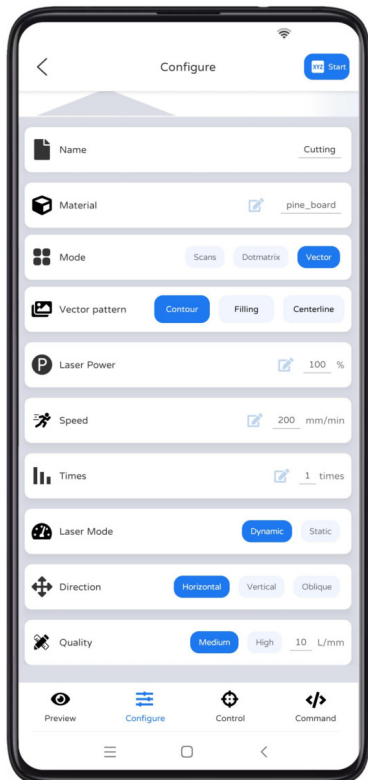

If you are cutting objects, refer to these Settings.

But they're not the best, and you need to adjust them accordingly!

The slower it goes, the more force it gains, and perhaps the more thickness it can cut.

But this is not the most correct, because you could get a fire!

7)

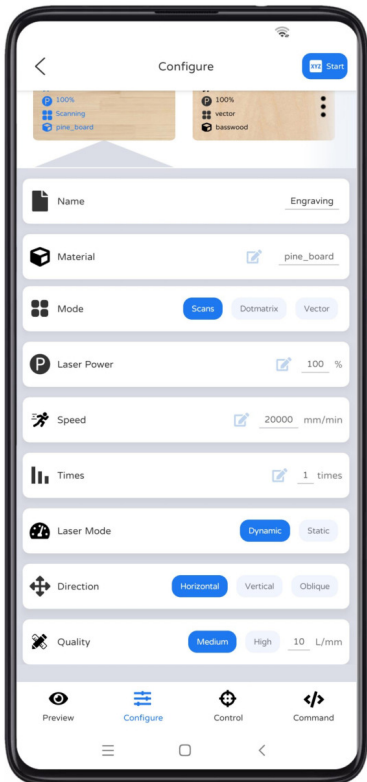

If you are engraving objects, refer to these Settings.

But they're not the best, and you need to adjust them accordingly!

You can change speed and quality, and they affect the effect of engraving. If the rate of engraving slows down, the result is more dark color.

The bigger the quality, the better the image, but it could also be a piece of burnt "bread" .

8)

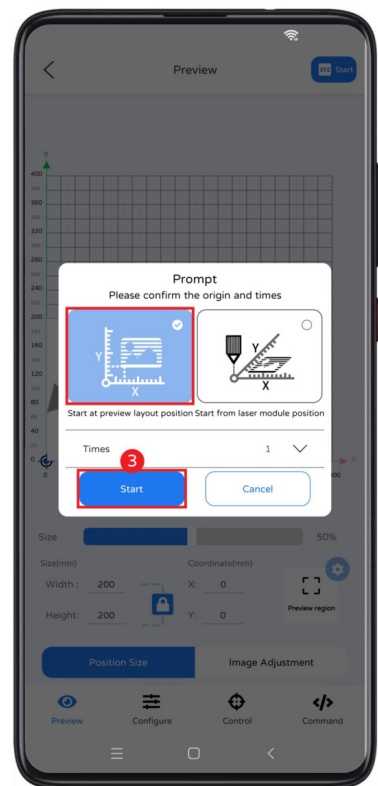
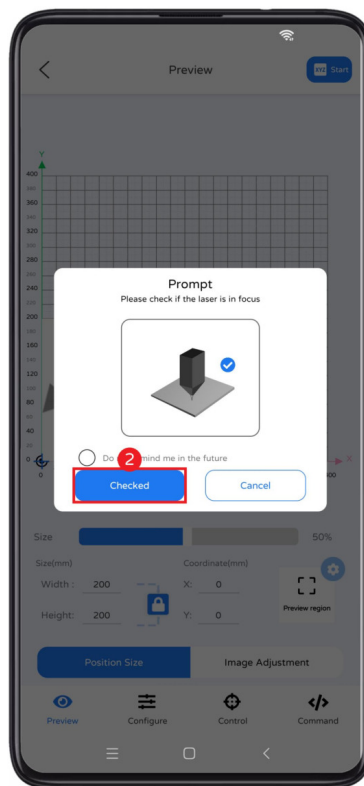
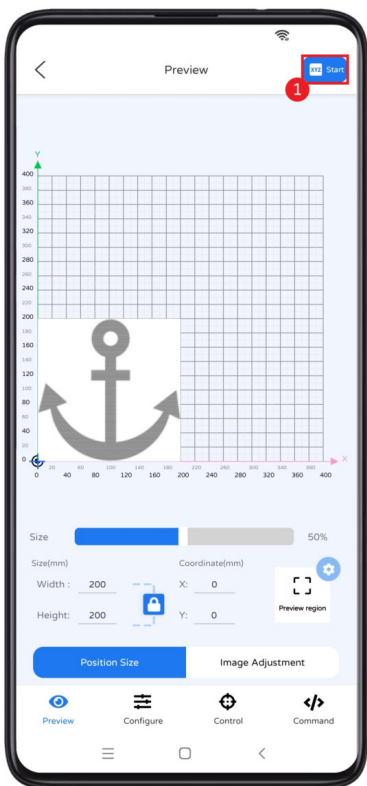

Get your laser module ready to move before cutting or engraving begins!

Your laser module has its own manual, please refer to settings!

9) Start engraving or cutting.

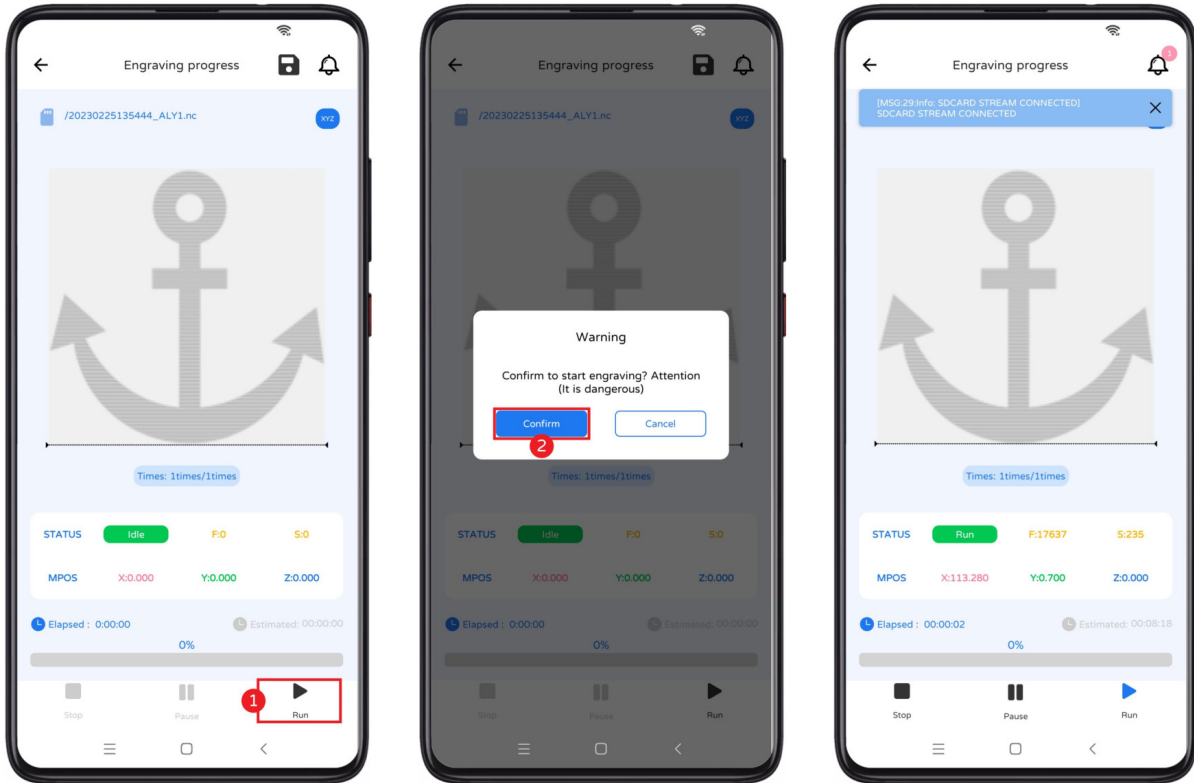

10) Other Softwares

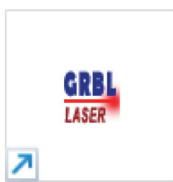

LaserGRBL

Freeware

<https://LaserGRBL.com/>

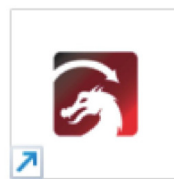

LightBurn

Paid Software

<https://LightBurnSoftware.com/>

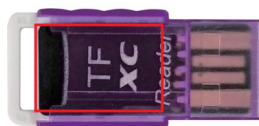

If you can't use the APP, please download the PC software.

TF card stores the user manual of PC software, please refer to it for learning support.

1 Adjust Wheels and Timing Belt

The machine was ready before departure. But sometimes, you need to adjust it.

1. When the Timing belt is too tight, the machine resistance increases, the engraving is abnormal, the pattern is misplaced, and the homing is abnormal;
When the Timing belt is too loose, the engraving is abnormal and homing is abnormal;
To adjust the tension of the Timing belt of the X-axis, refer to steps 1-3.
Adjust the tension of the Timing belt of the Y-axis, please refer to step 12 on page 9.
2. When the contact gap between the X-axis part and the Y-axis part is too small, the machine resistance increases, the carving appears abnormal, the pattern is misaligned, and the homing is abnormal;
When the contact gap between the X-axis part and the Y-axis part is too large, the gap will cause shaking, decrease the accuracy of the pattern, and cause abnormal homing;
Adjust the contact clearance between the X-axis part and the Y-axis part, please refer to steps 4-7.

1)

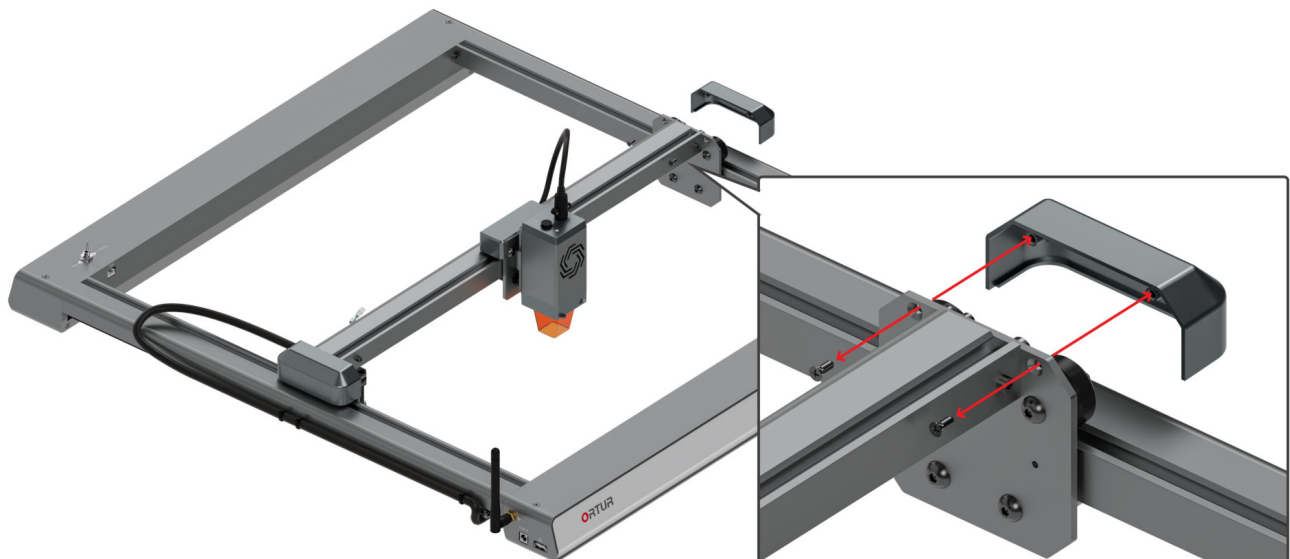

2)

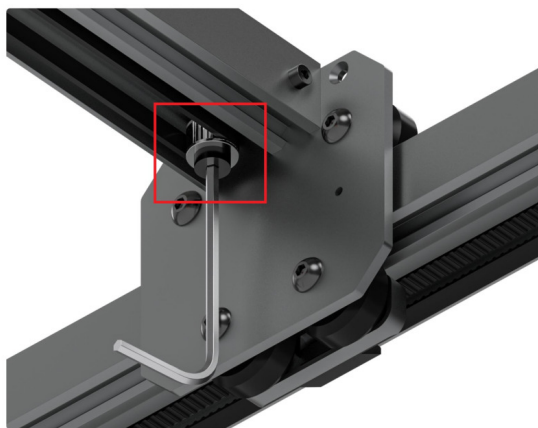

Loosen the screw, but don't remove it!

3)

If you tighten this screw, the timing belt of X-axis will tighten.

If you relax it, it will loosen.

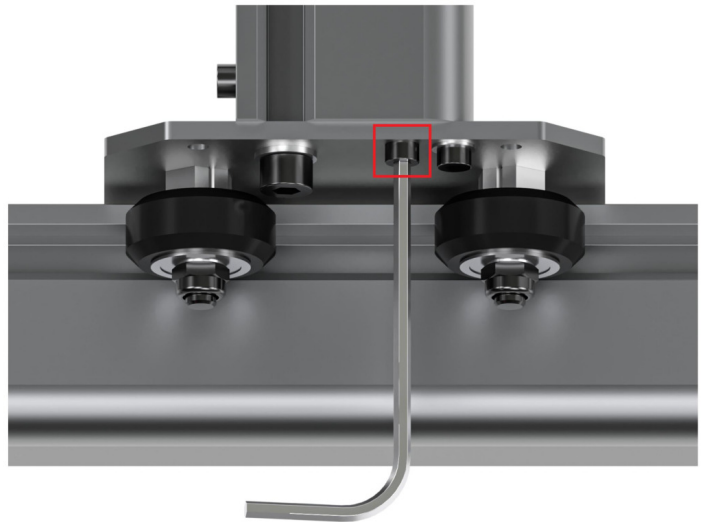

After the adjustment is completed, please reinstall the disassembled parts in reverse order and tighten the screws in step 2.

4)

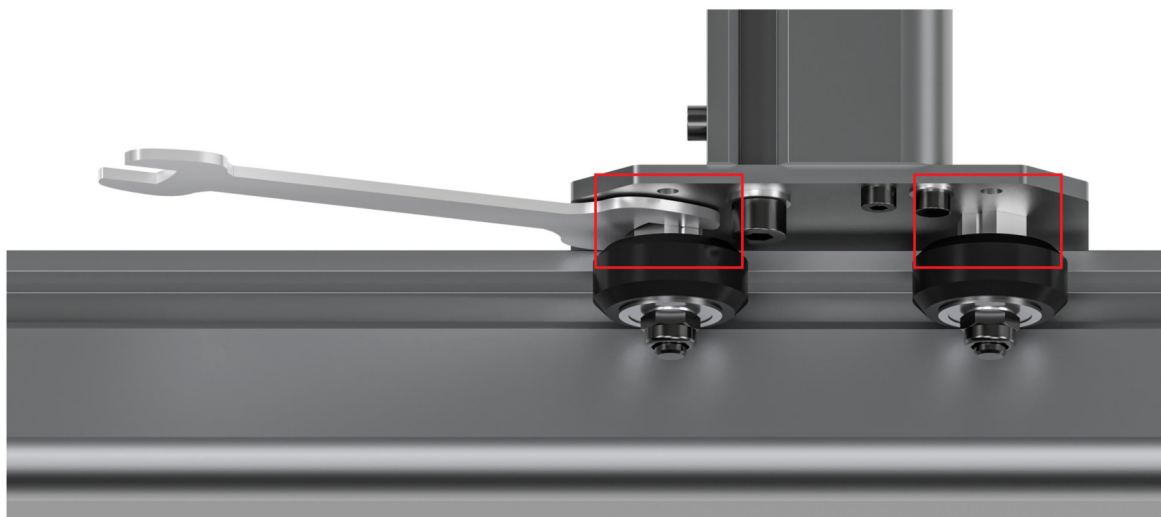

Adjust the eccentric nut, the clearance between the wheel and the slide rail will become larger or smaller.

The adjustment method on the left is the same as on the right.

5)

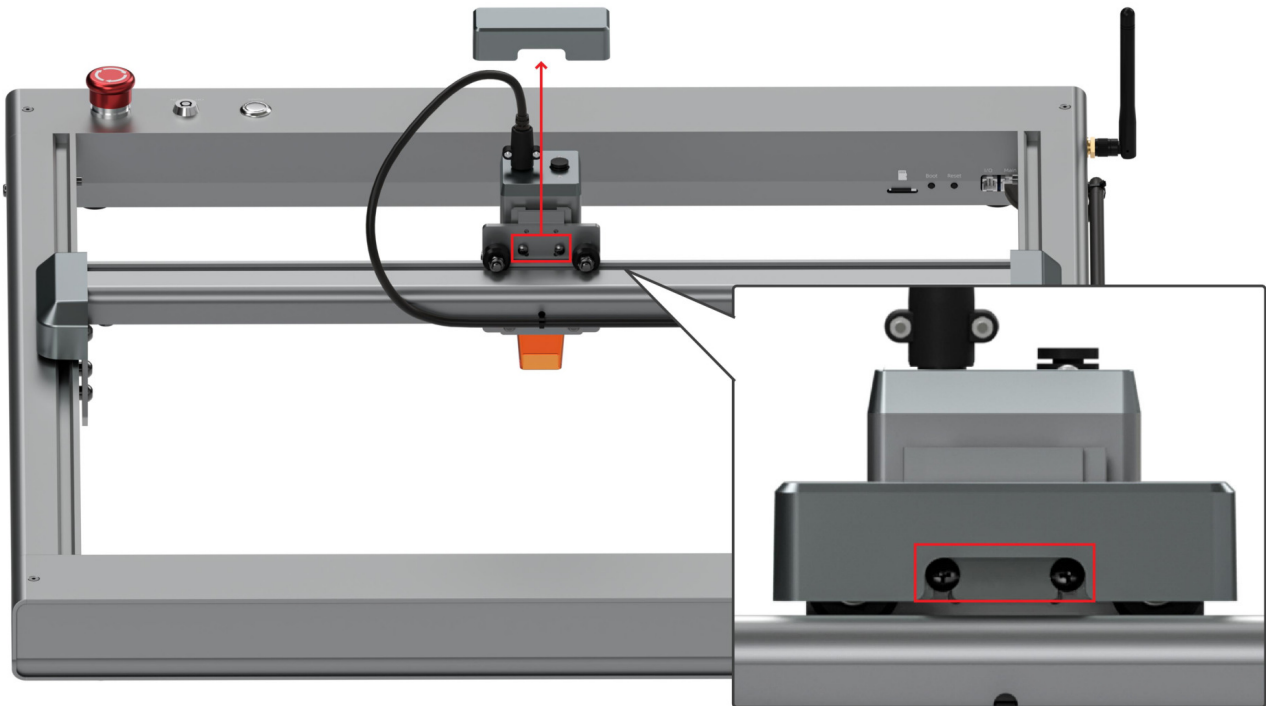

Loosen the screws, but don't remove them! Then remove the cover.

6)

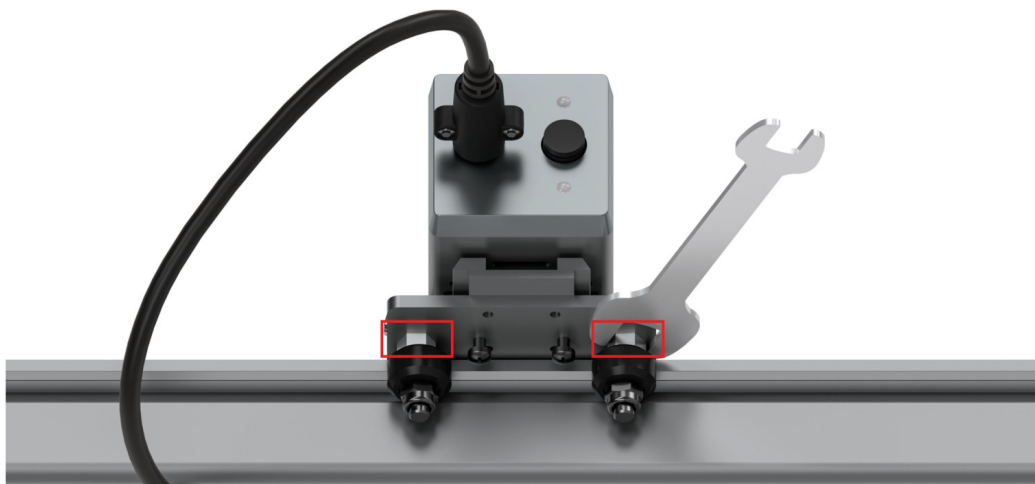

Adjust the eccentric nut, the clearance between the wheel and the slide rail will become larger or smaller.

7) After the adjustment is completed, please reinstall the disassembled parts in reverse order and tighten the screws in step 5.

J Questions and Answers

1) App Connection Failed

--- <https://www.youtube.com/watch?v=dwpoR5MdRc8>

2) When the Machine Boot Buzzes Alarm, or the Power Light is Red

Check whether the machine has inserted a TF card, which is in the card reader;
Make sure that the YRR switch points to the Y-Motor side;
Make sure that the arrow of the key switch points to "ON";
Check the emergency stop switch and turn it clockwise to eject it.

3) The status on the APP control page is Alarm

Please click to reset, and then click to unlock.

4) Connect the Machine with AP Mode

Turn off mobile data and scan the wifi network, you will see "OLM3_AP_xxxx".
Select this with the password 12345678 and launch the Laser Explorer.
Select the OLM3 found and the LU2-10A module at the bottom of the list.
You should now be able to connect.

5) The homing of the machine is abnormal, constantly hitting the machine frame

Please check whether the synchronous belt is installed correctly, or view the teaching video:

Y --- <https://www.youtube.com/watch?v=0OCNDKwtjNo>

X --- <https://www.youtube.com/watch?v=wjSDBLO7K5k>

6) The Engraving Effect is Skewed

Watch the instructional video to check the timing belts for the Y and X axes.

Y --- <https://www.youtube.com/watch?v=0OCNDKwtjNo>

X --- <https://www.youtube.com/watch?v=wjSDBLO7K5k>

7) Stop Engraving or USB Disconnection

Connect to the machine via USB, and you'll have a driver called "OLM3 xxxx" on your computer.
In it you can see some help documents, you'd better save it on your computer.
Then watch the tutorial video and upgrade your firmware version.

--- <https://www.youtube.com/watch?v=dwpoR5MdRc8>

8) The Indicator Lights Flickering Red and Yellow

Because the emergency stop button is pressed, please unlock!

9) Y-axis does not run

Make sure that the YRR switch points to the Y-Motor side;
Check whether the Y -axis motor wire is damaged.

10) Collection of OLM3 Video Tutorials

--- https://www.youtube.com/watch?v=9KLT28cZET0&list=PLCvoW8cWgVwcp4TZ9LXw75EUokZK3Ca_d

11) Unable to Run PC Software

If your computer system is win7 or win8, please install the driver before using PC software!



<https://zadig.akeo.ie/>

Please select the driver version 2.5 to download.

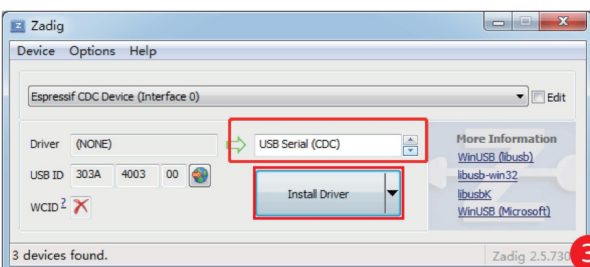
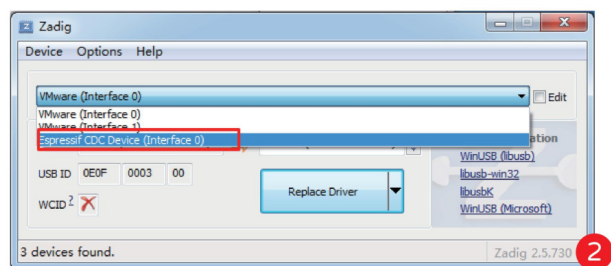
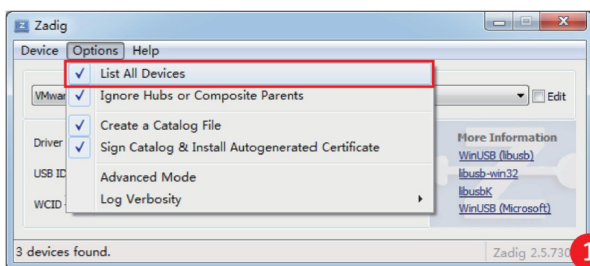

Please install the driver with administrator privileges, and attach the contents of the "red box".

12) Stop Engraving or USB Disconnection (windows)

Connect to OLM3 and power it on ,wait let it home.
On your windows, right click start menu.
A pop up menu will appear, click Device Manager.
In the Device Manager, please locate Disks and Ports.
In Disks, please identify ExpressF Mass Storage .(Might also appear as Expressi Mass Storage)
Right click -> click Disable Device -> Confirm.

13) Unable to Connect to Mac

The boot order in MacOS is correlated.
Power on the machine and let it go home.
Plug in the USB and start Lightburn.
Laser panel -> There is a drop-down menu in front of the device button.
Is cu.usbmodemxxxxxx listed? If so, click it.
You should be able to see a welcome message in the console.

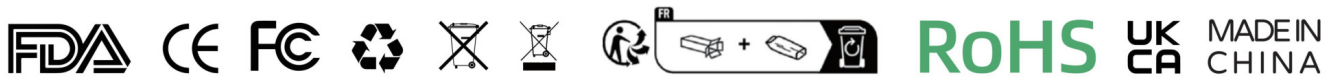

Address: No.1 Building, Jinzhong Smart Industrial Park, Changping, Dongguan 523558, Guangdong, China

