

Infrared Sensor Switch

3 Conductor Wire

WAC



Fixture Type:

Catalog Number:

Project: _____

Location: _____

Model	Finish
IR-96-24VDC-CCT-BK	Black
IR-96-24VDC-CCT-WT	White

PRODUCT DESCRIPTION

IR (Infrared) sensors switch works by turning the lights on when it becomes unobstructed. This cabinet/door sensors switch is perfect for installation into wardrobes, furniture cabinets and drawers with a 96W power capabilities. Designed to work with 3 conductor wire InvisiLED CCT & Dim-To-Warm system.

FEATURES

- Compatible with InvisiLED CCT / Dim-To-Warm tape system
- 24VDC
- Can be surface mounted with bracket provided or double sided adhesive
- 96W Max. power capabilities
- 5 years warranty

Notes: IR sensor must be mounted within 1-3 inches from cabinet door

LINE DRAWING

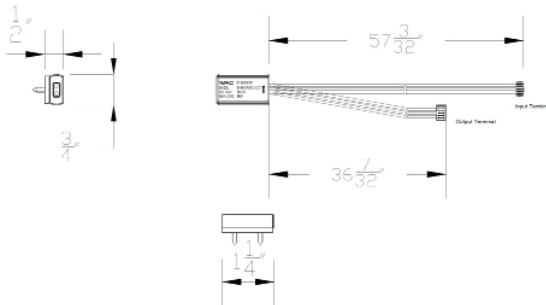

SPECIFICATIONS

Construction:	Plastic
Input:	24VDC, 96W Max.
Output:	24VDC, 96W Max.
Mounting:	Surface mounted with bracket provided or double sided adhesive
Finish:	White / Black
Environment:	50°F - 104°F Indoor used only Dry and damp location

waclighting.com
Phone (800) 526.2588
Fax (800) 526.2585

Headquarters/Eastern Distribution Center
44 Harbor Park Drive
Port Washington, NY 11050

Central Distribution Center
1600 Distribution Ct
Lithia Springs, GA 30122

Western Distribution Center
1750 Archibald Avenue
Ontario, CA 91761