

ZHANE 49 LINEAR SUSPENSION

PRODUCT FEATURES

- Ultra-modern in design and boasts hard and soft lines
- Acrylic diffuser provides a glare-free wash of light onto surfaces below
- Available in modern finishes
- Ships with your choice of energy efficient integrated LED lamping or fluorescent lamping
- Your option of fully dimmable integrated LED or fluorescent lamping creates the desired ambiance
- Protected by a 5-year warranty



LAMPING

Includes 40 watt, 2400 lumen 3000K linear LED strips. Has a maximum drop length of 6 feet. LED dimmable with a low-voltage electronic dimmer. Can be installed on a sloped ceiling up to 45°.

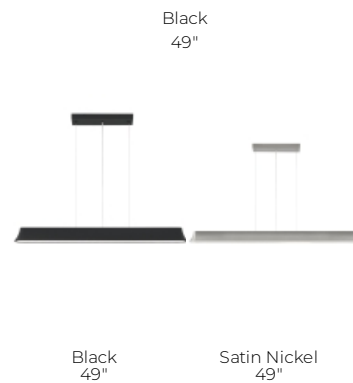

ORDERING INFORMATION

700LSZHN	LENGTH (A)	FINISH	LAMP
	49 49"	B BLACK RUBBERIZED S SATIN NICKEL	-LED LED 90 CRI 3000V 120V (T24) -LED277 LED 90 CRI 3000V 277V

700LSZHN _____

JOB NAME _____

NOTES _____



ZHANE 49 LINEAR SUSPENSION

SPECIFICATIONS

HARDWARE MATERIAL	Metal
SHADE MATERIAL	Acrylic
NET WEIGHT	8.5 lbs
HEIGHT	3in
WIDTH	4in
LENGTH	49in
UP LIGHT / DOWN LIGHT / BOTH?	
WET LISTED	
DAMP LISTED	Yes
DRY LISTED	
MIN. HANGING HEIGHT	10.2in
MAX HANGING HEIGHT	148.2in
TOTAL CORD LENGTH	72in
TOTAL STEM LENGTH	
STEM QTY	
SLOPED CEILING ADAPTABLE?	Yes 45° Max
GENERAL LISTING	ETL Listed
INCLUDES	

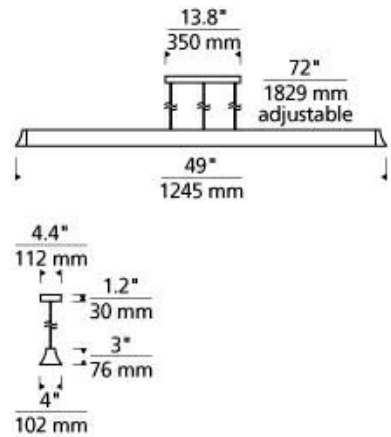

LAMPING SPECIFICATIONS

	LED LAMP	INTEGRATED LED	NON LED	NO LAMP
DELIVERED LUMENS		3100		
WATTS		40		
MAX WATTAGE PER BULB		40W		
INPUT VOLTAGE		120V 277V		
DIMMING TYPE*		ELV, TRIAC 0-10V		
CCT		3000K		
CRI		90 CRI		
LED LIFETIME				
L70		>50000		
AVERAGE BULB HOURS				
FIELD SERVICEABLE LED				
LAMP BASE		Integrated LED		
LAMP SHAPE		Integrated LED		
LAMP INCLUDED?		True		
WARRANTY**		5 Years		

* Dimming information available at www.techlighting.com/Downloads#dimming

** Visit techlighting.com for specific warranty limitations and details.

T20 / T24 INFORMATION

	Integrated LED	Replacement LED Lamp	No Lamp *
This product can be used to comply with California Building Energy Efficiency Standards 2016 Title 24 Part 6.	Yes		
This product can be used to comply with California Appliance Efficiency Standards 2016 Title 20 and may be shipped to and sold in California.	N/A		

* If a light fixture or component does not include a lamp or light source, it is the responsibility of the customer to select a lamp that meets the T24 and T20 requirements.

