

Slimline Anchors

700PRTT0_

1.6



GENERAL PRODUCT INFORMATION:



This product is suitable for indoor dry locations only.

This product should be used with Tech Lighting Kable Lite turnbuckles at the other end.



Install the Slimline Anchors

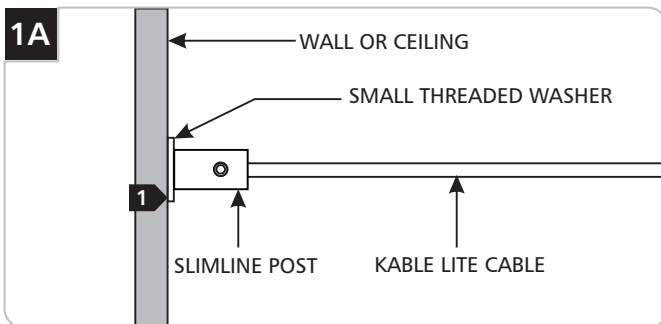

1 Use the small threaded washer when the Kable Lite cable is attached in-line to the slimline post.

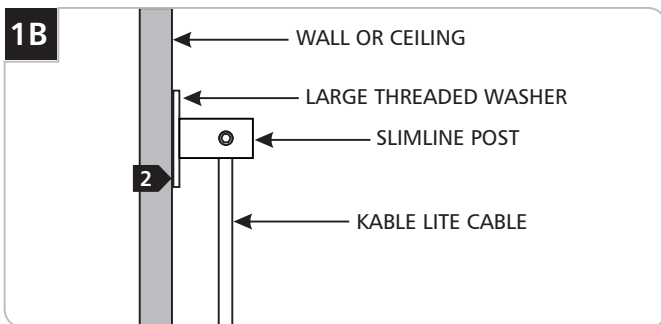

2 Use the large threaded washer when the Kable Lite cable is attached at an angle to the slimline post.

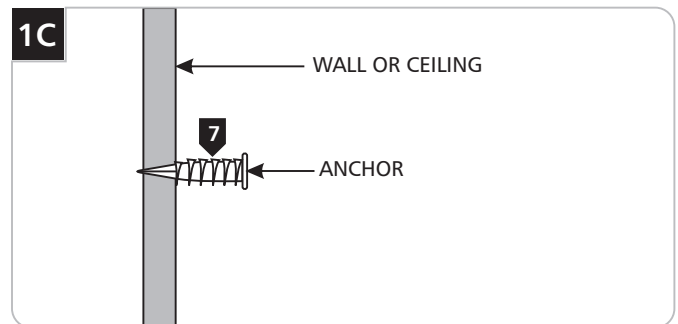

3 Select the right location for the anchors to be mounted.

4 Decide the Kable Lite cable separation. 1" is the minimum separation allowed (use the small threaded washer in this case).

6 Mark the location of the anchors on the wall or ceiling. The distance between the center points of the anchors should be the desired Kable Lite cable separation.

7 Tap the anchors at the marked point up to the threaded portion with a hammer.

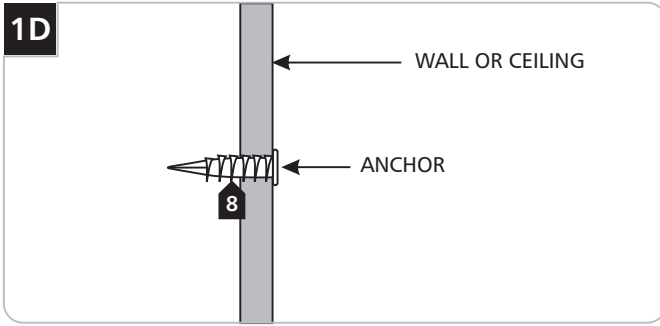

8 Screw the anchors in the rest of the way with a Phillips screwdriver.

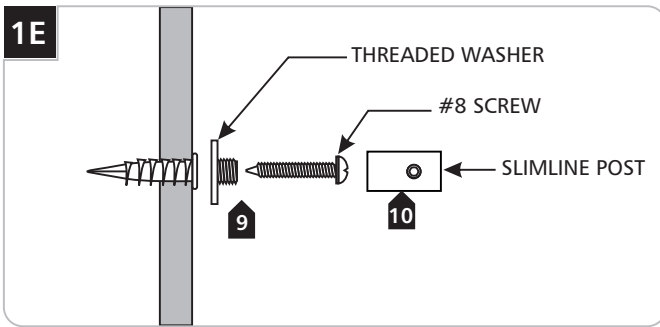

9 Attach the threaded washer to the anchor with the #8 screw.

10 Screw the slimline posts onto the threaded washers.

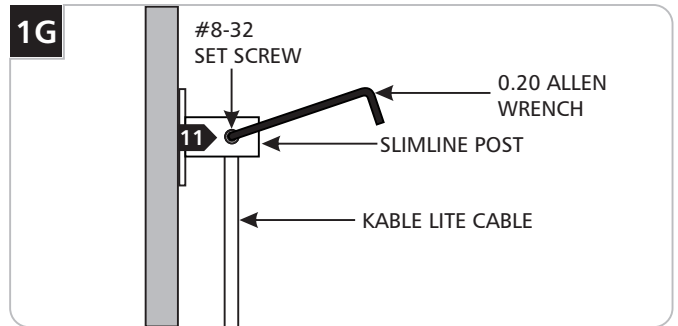
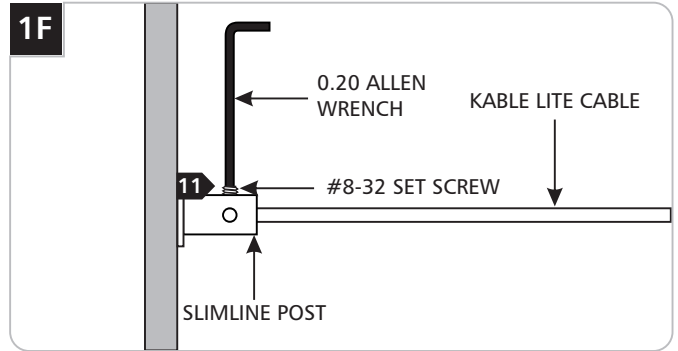

11 Insert one end of the Kable Lite cable into the slimline post and tighten the #8-32 set screws with the 0.20 Allen wrench to secure the wire. The other end of the cable should be attached to a turnbuckle.

SAVE THESE INSTRUCTIONS!



TECH LIGHTING®

7400 Linder Ave, Skokie, IL 60077

847.410.4400

www.techlighting.com

© 2008 Tech Lighting, L.L.C. All rights reserved. The "Tech Lighting" graphic is a registered trademark of Tech Lighting, L.L.C. Tech Lighting reserves the right to change specifications for product improvements without notification.

A Generation Brands Company