

SLAMP®



THE LEADING LIGHT

ASSEMBLING INSTRUCTIONS

LA LOLLO APPLIQUE

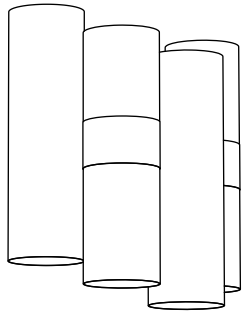
Applique
Dim: 11" x 6-1/4" x h 11-3/4"



-  2 x 6W E12 LED Filament or
-  2 x 6W E12 LED

CE IP 20  



c.n. 4010196
Conforms to UL Std. 1598
Cert. to CSA Std. C22.2 No. 250.0-08

MADE IN ITALY - INTERNATIONAL PATENT
Utility Model, Ornamental Design, Trade Mark, Copyright on Artist Design

SLAMP S.p.A. Via Vaccareccia, 12/14 - 00071 Pomezia (Roma)
Tel.+39 06 9162391 (r.a.) Fax 06 91623933 - info@slamp.it - www.slamp.com

OK - off



A Before assembling the lamp, make sure that main switch is off.



Do not remove the protective bag during this step

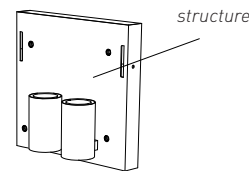
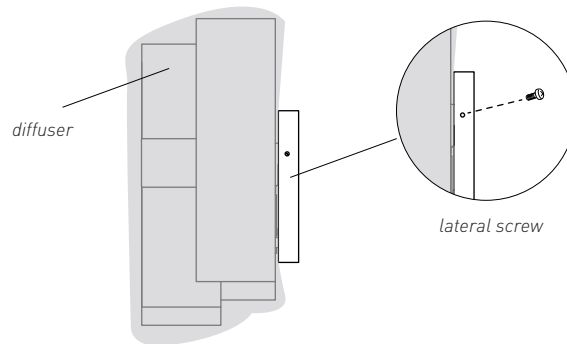

B After removing the lamp from its packaging, separate the diffuser (leaving it in the plastic) from the structure, unscrewing the lateral screws as shown.

ELECTRICALLY CONNECT THE LAMP

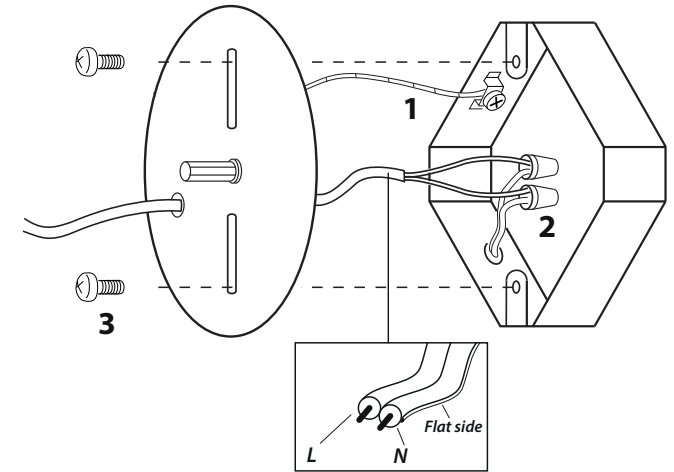

1) Connect the green/yellow-green ground-wire to both the junction box's green screw and the plate, using the UL and CSA-listed green wire and respective terminal nut.

2) Connect N (neutral) supply line lead (flat side on transparent cable) to junction box white wire. Connect the L or brown (color may vary) supply line lead to junction box black wire; connect power leads to circuit breaker, or other protection device.

C **3)** Secure the plate to junction box using provided screws and screw-anchors, avoiding damage to the wires.

HANG THE STRUCTURE ON THE WALL

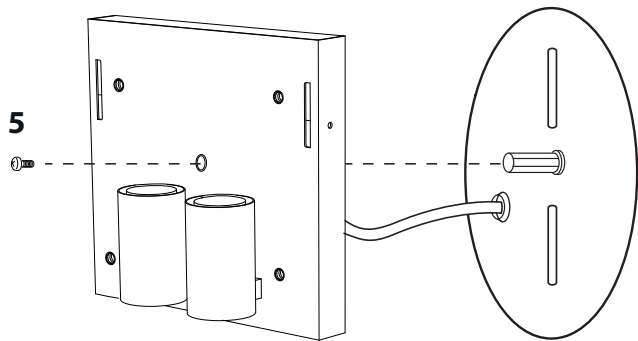

5

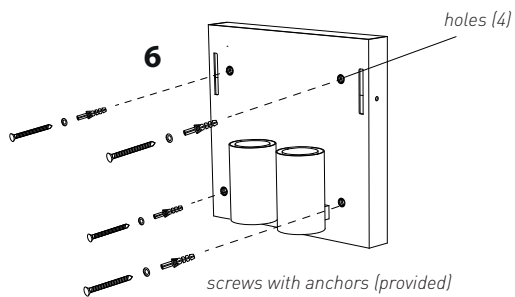

6

holes (4)

screws with anchors (provided)

5) Fix the structure to the plate using the provided screw as shown.

6) Position the screw holes by using the provided support structure, making sure the bulb sockets are as shown in the figure. Place the support on the wall, and install the 4 anchors and screws.

D

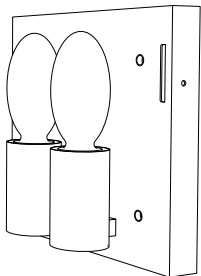

E

Insert the bulbs, using only the indicated wattage, to avoid damaging the product.

CONNECT THE DIFFUSOR TO THE STRUCTURE

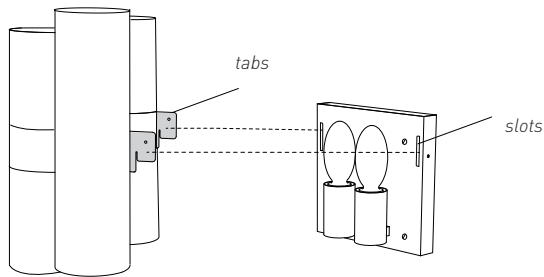

tabs

slots

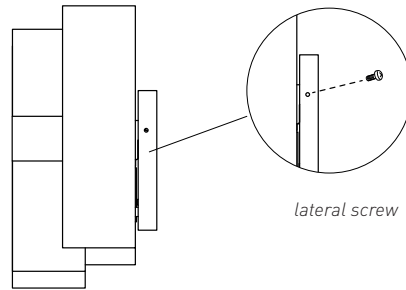

lateral screw

F

Fit the diffusor tabs in the structure's slots. Secure the the lamp to the wall by using the screws removed in step b.

CHANGING BULBS

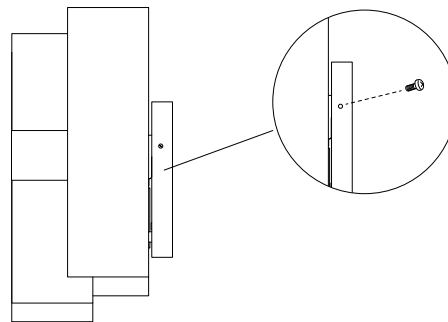

To change bulbs, remove the lateral screws and diffuser. Change bulb or bulbs, and reinstall diffuser and screws.

Our lamp's surfaces should be cleaned using a soft, water damp cloth, otherwise use antistatic spray. Under no circumstances should acetone, trichloroethylene, ethyl alcohol, ammonia, or detergent containing even small quantities of these substances be used, because they attack plastic surfaces. Scouring powder, abrasive creams and all cleaning equipment with rough surfaces, should also be avoided.



SLAMP is in conformity with Directive 2002/96/EC (Waste Electrical and Electronic Equipment - WEEE).

ENGLISH/ INFORMATION FOR USERS

Directive 2002/96/EC (Waste Electrical and Electronic Equipment - WEEE)

The use of the WEEE symbol indicates that this product may not be treated as household waste. By ensuring this product is disposed of correctly you will help protect the environment. For more detailed information about the recycling of this product, please contact your local authority, your household waste disposal service provider or the shop where you purchased the product.



If the lamp's external electric wire has been damaged, to avoid dangers, it must be replaced exclusively by manufacturer, by its customer service, or by other skilled workers.