

SLAMP®
THE LEADING LIGHT

ARIA INFINITA

2rd ARRANGEMENT

DESIGN BY ZAHA HADID

LAMP INSTALLATION - INSTALLAZIONE LAMPADA

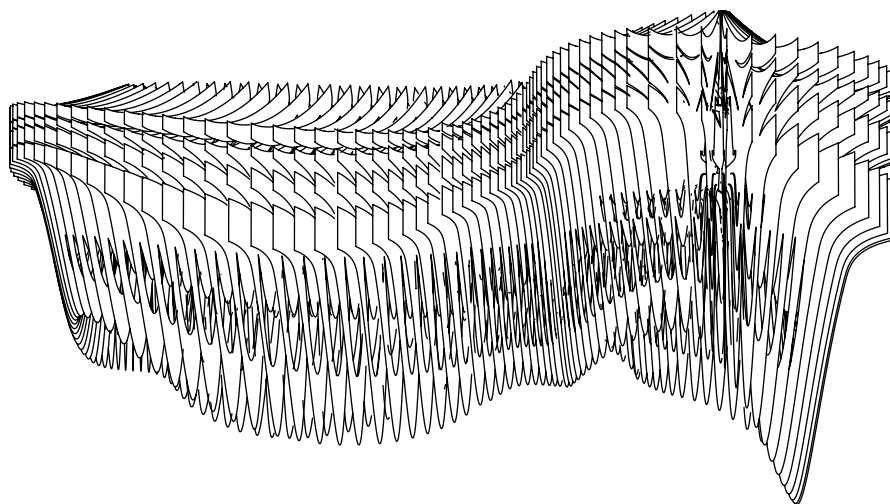

54 x 12 W - LED Filament bulbs

+

14 x 12 W - LED Spot PAR 38

(290 Kg)



EN- READ THE INSTRUCTIONS BEFORE UNPACKING THE LAMP!

IT- PRIMA DI DISIMBALLARE LA LAMPADA LEGGERE LE ISTRUZIONI!

100% HANDMADE IN ITALY

WARNING - ATTENZIONE - AUFMERKSAMKEIT - ATTENTION

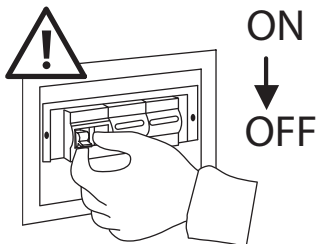

EN- Turn off the mains before installing the lamp.

IT- Spegner e l'alimentazione generale prima di installare la lampada.

DE- Schalten Sie die Stromversorgung aus, bevor Sie die Lampe installieren.

FR- Coupez le courant avant d'installer la lampe.

DAMAGE - DANNEGGIAMENTO - BESCHÄDIGUNG - ENDOMMAGER

EN- If the lamp's external electric wire has been damaged, to avoid dangers, it must be replaced exclusively by manufacturer, by its customer service, or by other skilled workers.

IT- Se il cavo flessibile esterno di questo apparecchio viene danneggiato, deve essere sostituito esclusivamente dal costruttore, dal suo servizio di assistenza, o da personale qualificato equivalente, al fine di evitare pericoli.

DE- Wird das äußere Stromkabel dieses Gerätes beschädigt, darf es zur Vermeidung von Gefahren nur durch den Hersteller, durch seinen Kundendienst oder durch gleichwertiges Fachpersonal ausgetauscht werden.

FR- Afin d'éviter tout danger, si le câble électrique externe du luminaire a été endommagé, il doit être remplacé exclusivement par le fabricant, par le service client ou par des professionnels compétents.



LIGHTBULB WATTAGE - WATTAGGIO LAMPADINE - WATT-ZAHL DER LEUCHTMITTEL - PUISSANCE DES AMPOULES

EN- The Company's suggested lightbulb wattage and size ensure that each each product exhibits optimal illumination and aesthetic impact: E27/E26: Ø6 cm (2-1/4") E14/E12 Ø4,5cm (1-1/2"). Stronger wattage may be used exclusively with a LED bulb of the same size.

IT- Il wattaggio delle lampadine sul seguente catalogo è suggerito dall'azienda per un ottimale balance fra resa luminosa ed estetica del prodotto oltre che alla dimensione del bulbo E27: Ø6 cm - E14: Ø4,5cm. Possono essere utilizzati wattaggi superiori purchè si utilizzino esclusivamente lampadine LED con una dimensione del bulbo adeguata.

DE- Die Watt-Zahl der Leuchtmittel im folgenden Katalog wird vom Unternehmen für ein optimales Gleichgewicht zwischen Lichtleistung und Produktästhetik sowie der Größe des Leuchtmittels E27 vorgeschlagen: Ø6 cm - E14: Ø4,5cm. Höhere Watt-Zahlen können verwendet werden, vorausgesetzt Sie verwenden ausschließlich LED-Lampen mit einer geeigneten Lampengröße.

FR- La puissance des ampoules indiquée sur ce catalogue est suggérée par l'entreprise pour un équilibre optimal entre le rendement lumineux et l'esthétique du produit ainsi que la taille de l'ampoule E27 : Ø6 cm - E14 : Ø4.5cm. Des puissances plus élevées peuvent être utilisées à condition que ce soit des ampoules LED d'une taille appropriée.

1 COMPONENTS LIST - ELENCO COMPONENTI



x32 SCREW ANCHORS



x32 SCREWS



x32 CEILING ATTACHMENT



x32 GRIPLOCK



x20 WHITE SCREWS

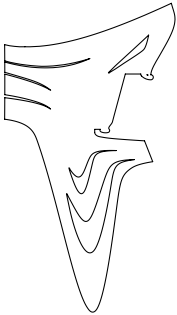

144 FINS

x3 SET 1_ fins n°1/n°12

x3 SET 2_ fins n°13/n°24

x3 SET 3_ fins n°25/n°36

x3 SET 4_ fins n°37/48

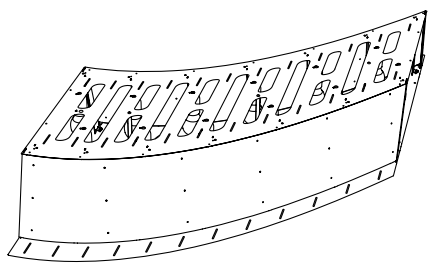

x2 MODULE

A

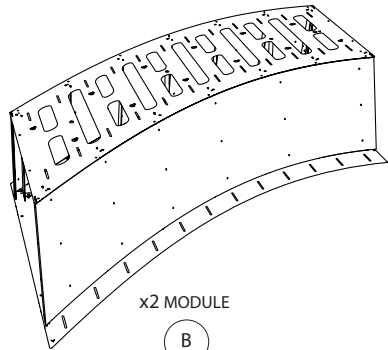

x2 MODULE

B

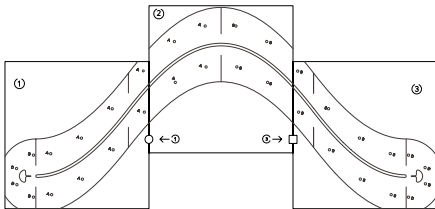

x1 DRILLING TEMPLATE

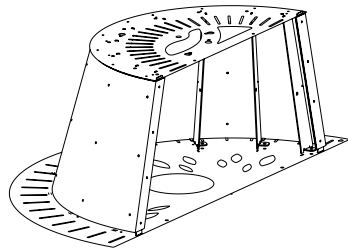

x2 MODULE

D

2 UNBOXING- DISIMBALLARE

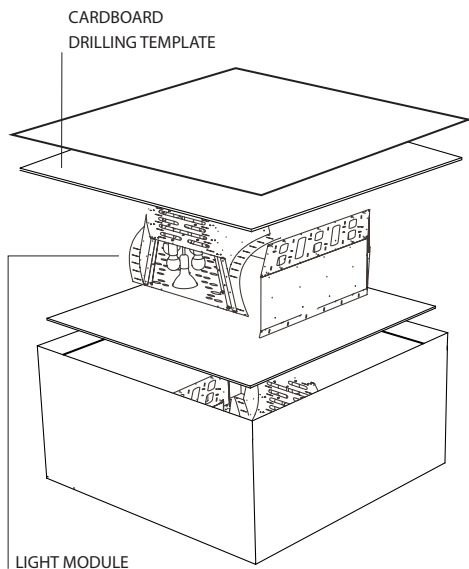

EN-Attention: You need 4 people to install the lamp due to its weight (322 Kg) and size.

Unwrap the cardboard drilling template and the light modules.

IT-Attenzione! Date le misure e il peso (322Kg) della lampada installarla in 4 persone.

Estrarre la dima di appendamento e i cestelli.



3 FIX THE CARDBOARD DRILLING TEMPLATE- FISSARE LA DIMA

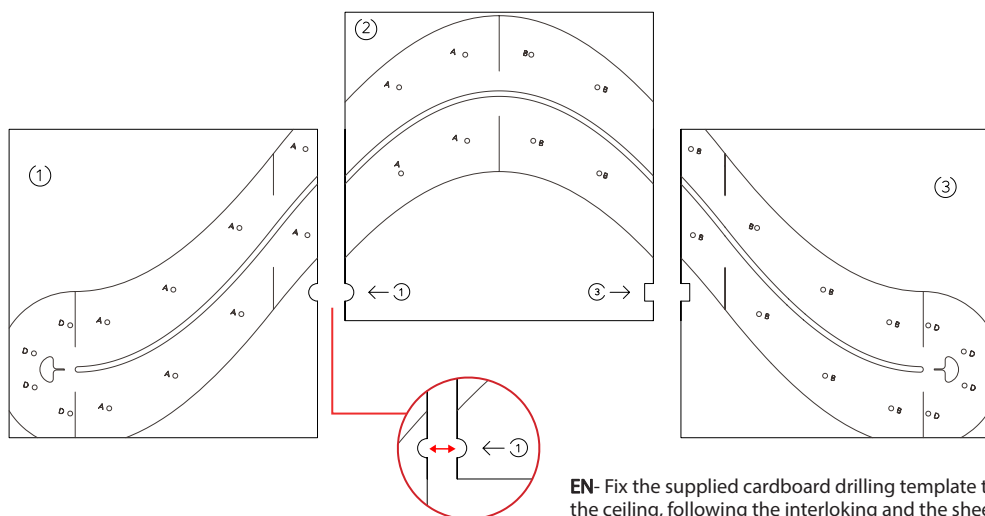

EN- Fix the supplied cardboard drilling template to the ceiling, following the interlocking and the sheet numbering.

IT- Fissare la dima al soffitto seguendo gli incastri e la numerazione su i singoli fogli.

4 DRILLING TEMPLATE- DIMA

EN- Drill the ceiling following the holes on the drilling template. Insert the screw anchors. Mount the ceiling attachments with the supplied screws.

IT- Forare il soffitto in corrispondenza dei fori sulla dima. Inserire i tasselli nei fori. Fissare i rosoni tramite le viti fornite.

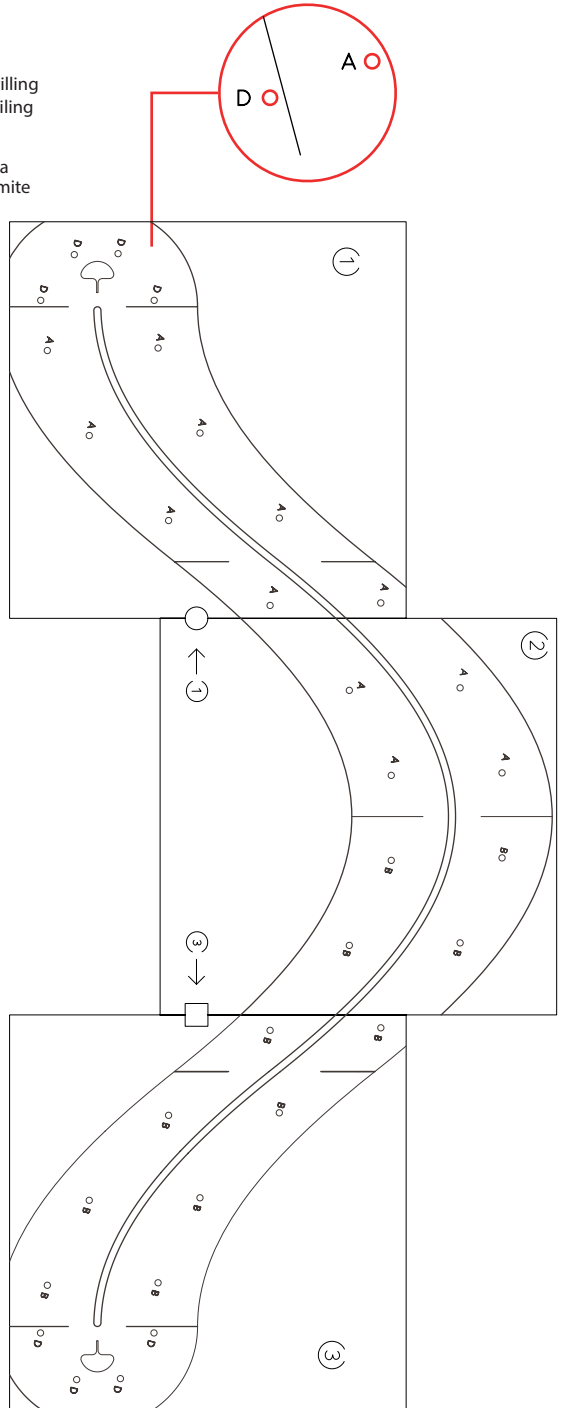
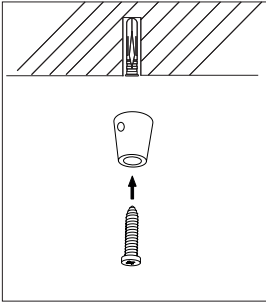

5 SEQUENCE ASSEMBLY- SEQUENZA DI MONTAGGIO

EN- Follow the module lights numbering to install the lamp. Beware of sequence labeling on the module.

IT- Rispettare la progressione dei diffusori per installare la lampada. Prestare attenzione alle etichette riportate su ogni modulo.

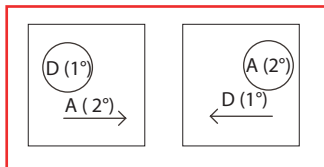

SEQUENCE LABELING ON THE MODULE
ETICHETTE SU I MODULI

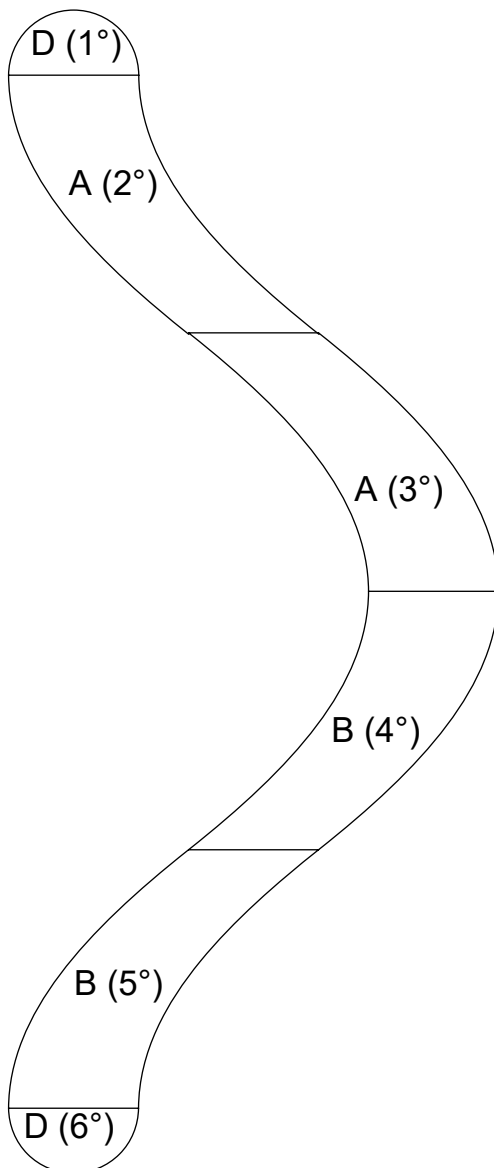

5 FIX THE STRUCTURE - FISSARE LA STRUTTURA

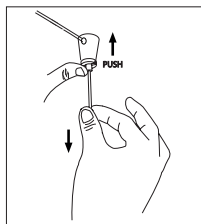
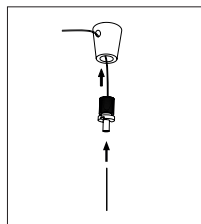

EN- Thread the steel cable inside the griplock and tighten and choose the heights. Join the modules by screwing up and down the plaques.

IT- Inserire il cavo d'acciaio nel morsetto e regolare l'altezza. Unire i cestelli avvitando le placca superiore e inferiore.

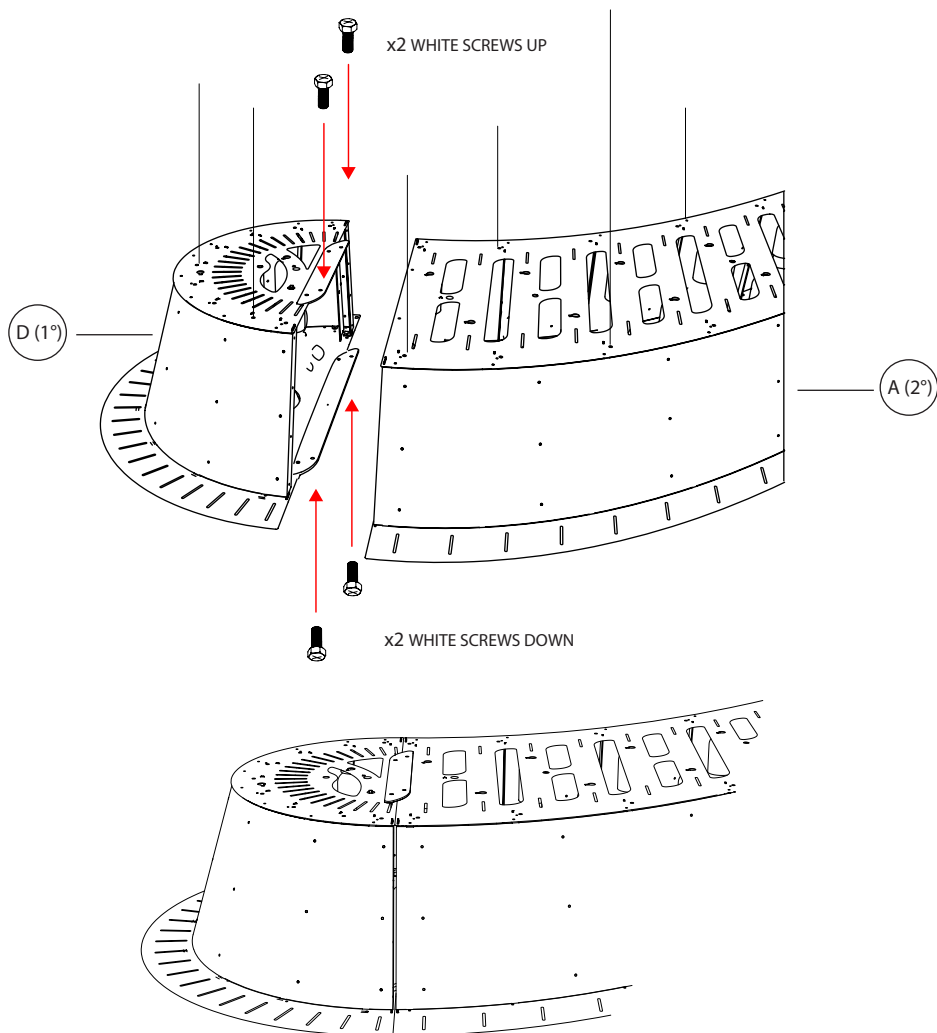

5 SCREW IN LED BULB AND SPOT LED - INSERIRE LAMPADINE E FARETTI

EN- Screw at the first the bulb and after the spot led.

IT- Inserire le lampadine e successivamente gli spot led.

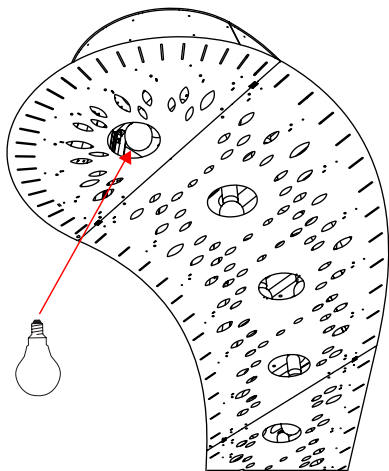

54 x 12 W -
LED Filament bulbs

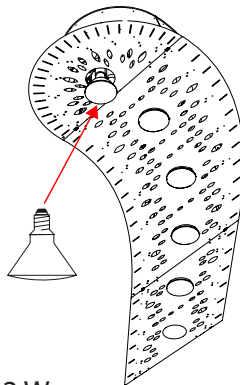

14 x 12 W -
LED Spot PAR 38

6 ELECTRICAL CONNECTION - CONNESSIONE ELETTRICA

EN- There is one electrical power wire.
The electrical connection between the module is entrusted to the female and male connectors.

IT- E' presente un solo cavo di alimentazione .
La connessione tra i cestelli avviene tramite i connettori maschio femmina.

FEMALE AND MALE CONNECTORS
CONNETTORI MASCHIO FEMMINA

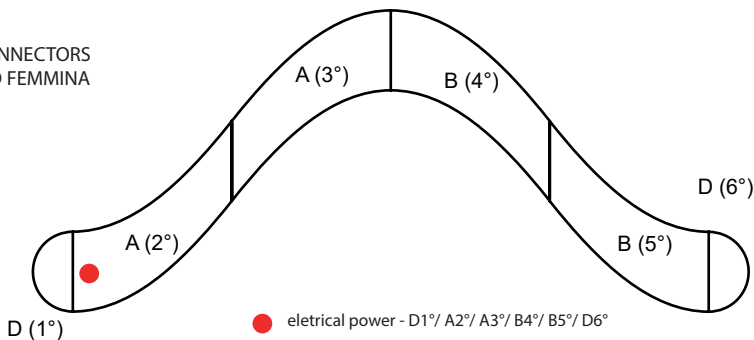
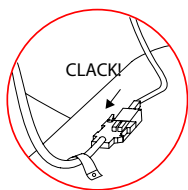

7 LAMP LAYOUT - LAYOUT LAMPADA

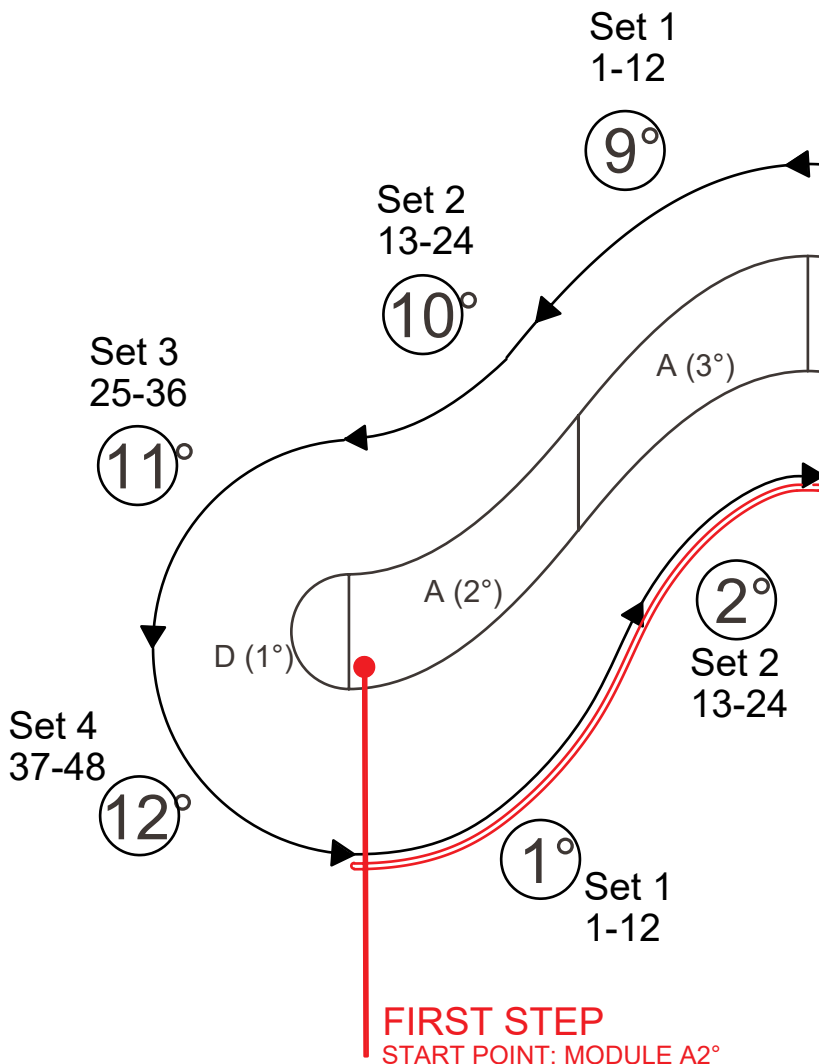

EN- FIRST STEP: start to hang the Set 1 by fin n.1 until n.48 in the module A2°
SECOND STEP: start to hang the Set 1 by fin n.1 until n.48 in the module D6°
Complete the layout insert the Set 1 by fin n.1 from where the previous Set 4 ends.

IT- PRIMO STEP: appendere il Set 1 nel moulo A2°, iniziando dal braccio n.1 fino al n.48
SECONDO STEP: appendere il Set 1 nel modulo D6°, iniziando dal braccio n.1 fino al n.48
Completare la configurazione inserendo il braccio n.1 del Set 1 da dove termina il Set 4 precedentemente installato.

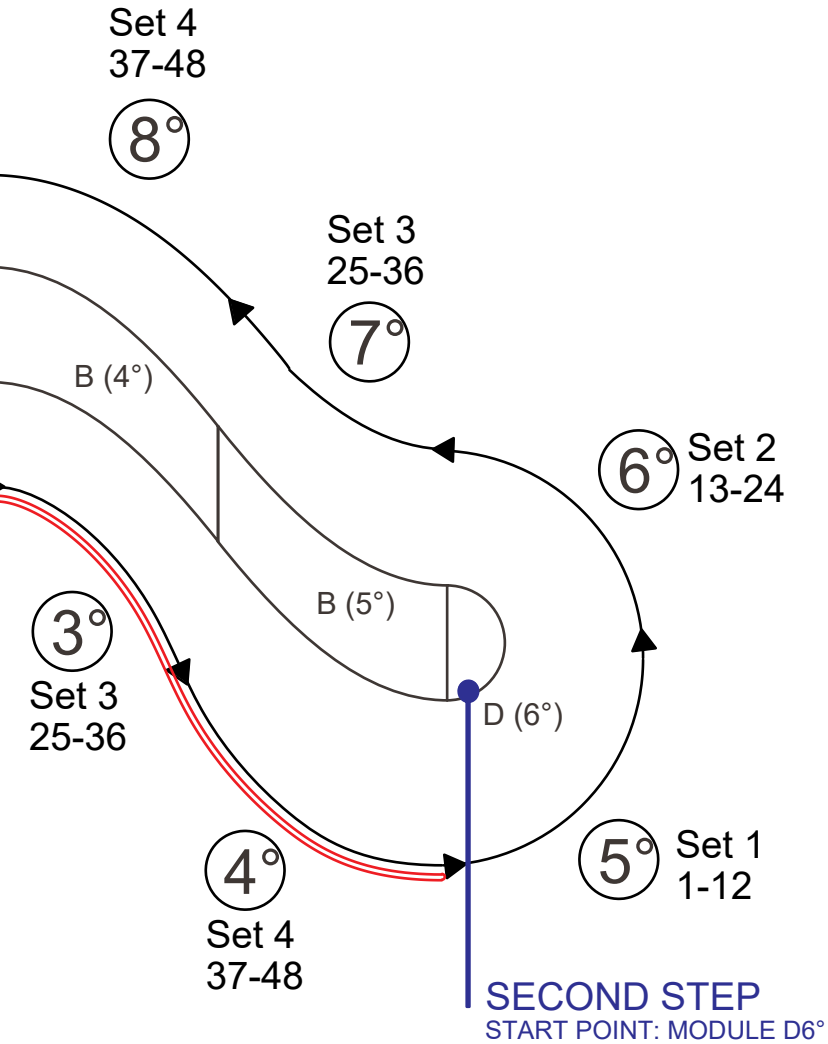

8 LAMP LAYOUT - LAYOUT LAMPADA

EN- Start assembling the decorative elements with Set1 fin n.1

IT- Iniziare il montaggio degli elementi decorativi con il braccio n.1 del Set1.

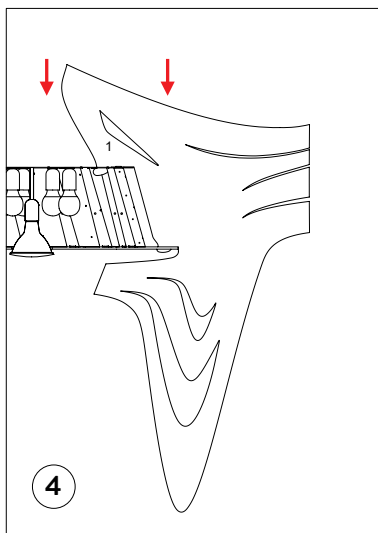
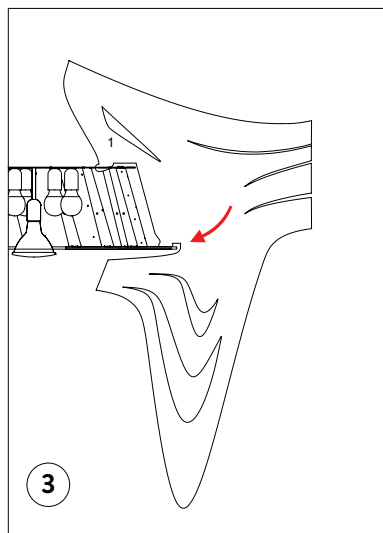
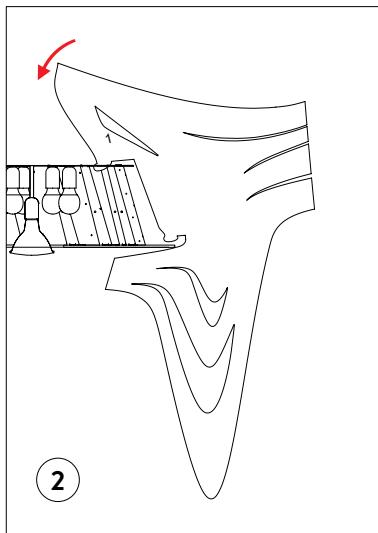
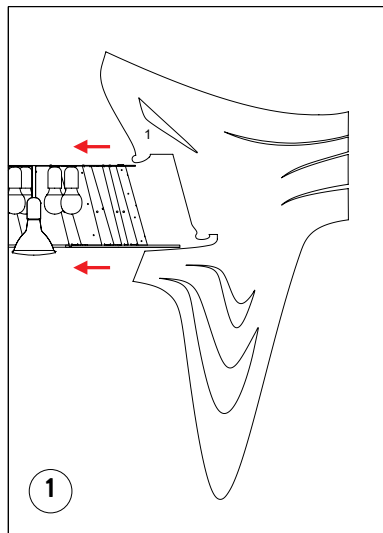
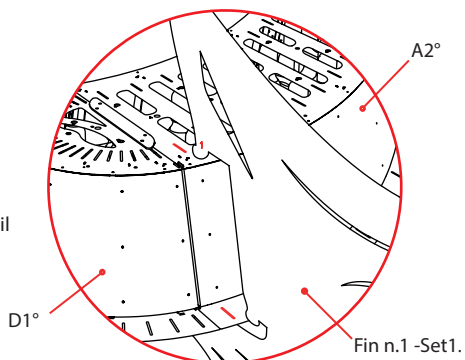



EN- SLAMP complies with the EU (European Union) Directive of 2002 (2002/96 / EC) on waste electrical and electronic equipment, which aims to reduce the impact of electronic waste on the environment. The WEEE Directive has been transposed into the laws of all member states of the European Union.

IT- SLAMP è conforme alla Direttiva UE (Unione Europea) del 2002 (2002/96/CE) riguardante i rifiuti di apparecchiature elettriche ed elettroniche, che mira a ridurre l'impatto di rifiuti elettronici sull'ambiente. La Direttiva RAEE è stata recepita dalle leggi di tutti gli stati membri dell'Unione Europea.

DE- SLAMP erfüllt die EU-Richtlinie (Europäische Union) des Jahres 2002 (2002/96/EU) bezüglich Abfällen elektrischer und elektronischer Geräte, die darauf abzielt, den Umwelteinfluss elektronischer Abfälle zu verringern. Die RAEE-Richtlinie wurde von den Gesetzen aller Mitgliedsstaaten der Europäischen Union ratifiziert.

FR- SLAMP est conforme à la directive UE (Union européenne) de 2002 (2002/96/CE) relative aux déchets d'équipements électriques et électroniques, qui vise à réduire l'impact des déchets électroniques sur l'environnement. La directive DEEE a été transposée dans les législations de tous les États membres de l'Union européenne.



CLEANING - PULIZIA - REINIGUNG - NETTOYAGE

EN- Our lamp's surfaces should be cleaned using a soft, water damp cloth, otherwise use antistatic spray. Under no circumstances should acetone, trichloroethylene, ethyl alcohol, ammonia, or detergent containing even small quantities of these substances be used, because they attack plastic surfaces. Scouring powder; abrasive creams and all cleaning equipment with rough surfaces, should also be avoided.

IT- Le superfici delle nostre lampade vanno pulite con un panno soffice inumidito con acqua, in alternativa utilizzare uno spray antistatico. Bisogna assolutamente evitare l'uso di acetone, alcool, trielina, ammoniaca, o di prodotti che contengano anche in minime quantità di questi detersivi. Evitare anche i detersivi in polvere, le paste abrasive e gli strumenti di pulizia con superficie ruvida quali le pagliette o le spugne ruvide.

DE- Die Oberflächen unserer Leuchten werden mit einem weichen, mit Wasser angefeuchteten Tuch gereinigt, alternativ können Sie ein Antistatikspray verwenden. Azeton, Alkohol, Trichloräthylen, Ammoniak oder Produkte, die auch nur minimale Mengen dieser Reinigungsmittel enthalten, müssen unbedingt vermieden werden. Vermeiden Sie auch Reinigungsmittel in Pulverform, Scheuerpasten und Reinigungswerkzeuge mit rauer Oberfläche wie Stahlwolle oder raue Schwämme.

FR- La surface du luminaire doit être nettoyé à l'aide d'un chiffon doux humidifié d'eau ou d'un liquide antistatique. En aucun cas, des produits tels que l'acétone, le trichloroéthylène, l'alcool éthylique, l'ammoniac ou un détergent contenant même de petites quantités de ces substances ne doivent être utilisés. Toute poudre à récurer, crème abrasive et tous les produits de nettoyage ayant une surface rugueuse doivent être également évités.

SLAMP®

100% HANDMADE IN ITALY - INTERNATIONAL PATENT- Utility Model, Ornamental Design, Trade Mark, Copyright on Artist Design

SLAMP S.p.A. Via Vaccareccia 12/14 - 00071 Pomezia (Roma)

Tel.+39 06 9162391 - Fax 06 91623933 - info@slamp.it - www.slamp.com



SLAMP®
THE LEADING LIGHT