

FOREVER
SCHONBEK

SEDUCTION
SJW4314



THIS DESIGN IS THE PROPRIETARY
TRADE DRESS/TRADEMARK OF
W SCHONBEK LLC.

FOREVER
SCHONBEK



All electrical components must be installed by a licensed electrician in accordance with the National Electric Code and the appropriate local electrical codes.

Fixture must be assembled per the provided instructions. Altering number of crystal modules may cause product failure and will void warranty.

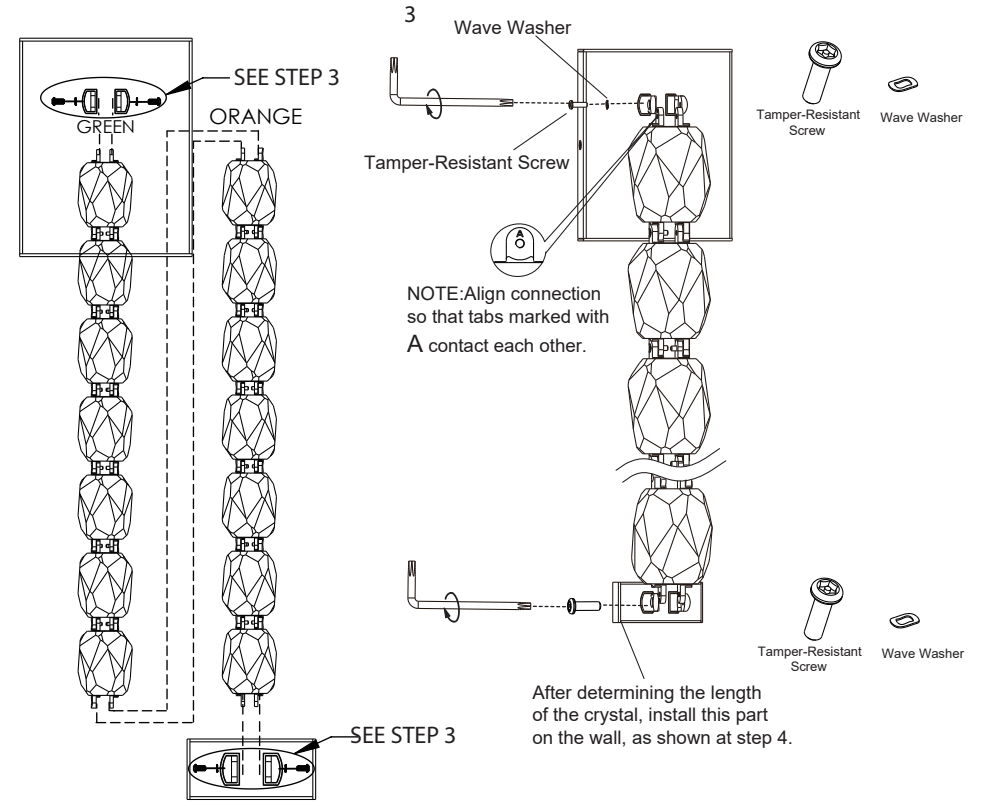
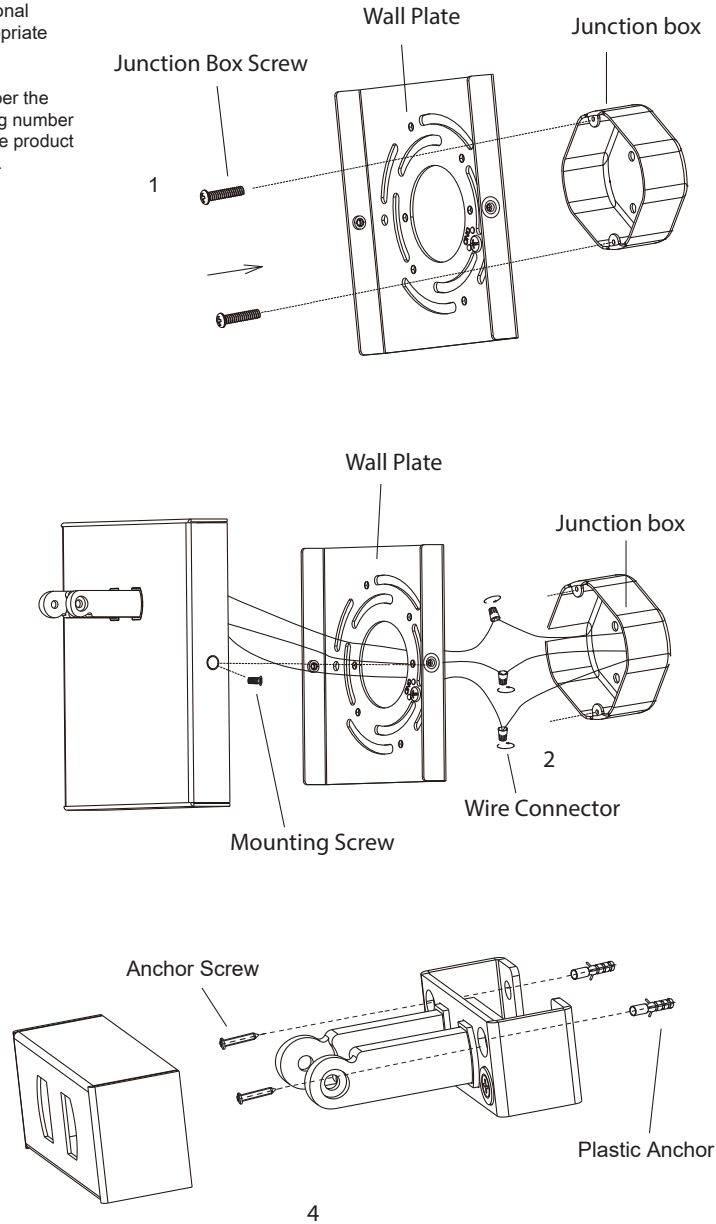

Each string of lights is identified by colored straps. Remove straps before installing. Connect sections as shown in the figure above. First, connect Green section to backplate. Attach Orange section to end of green section.

FULLY ASSEMBLE FIXTURE BEFORE TURNING ON POWER. TO ADJUST 3CCT SETTING, TURN OFF BEFORE ADJUSTING SWITCH.

Tabs marked 'A' must contact each other at connection.

