



Project: _____

Location: _____

Fixture Type: _____

Catalog Number: _____

AVAILABLE FINISHES:



Razor

FM-4716

PRODUCT DESCRIPTION

A thick slab of pristine glass rests on perfectly crossed blades for a subtle design with intriguing intensity. The timeless yet modern look is only surpassed by the innovative endurance of the technology, as powerful LEDs illuminate rich, ambient light for years. Perfect for transitional and industrial-inspired spaces, Razor cuts a mean figure anywhere you mount it.

FEATURES

- ACLED driverless technology
- Polished 304 stainless steel hardware, etched glass diffuser

SPECIFICATIONS

Rated Life	80000 Hours
Standards	ETL, cETL, Damp Location Listed
Input	120 VAC, 50/60Hz
Dimming	ELV
Mounting	Can be mounted on ceiling or wall in all orientations
Color Temp	3000K
CRI	90
Construction	Stainless Steel construction with etched glass

REPLACEMENT PARTS

RPL-GLA-4716 - Glass

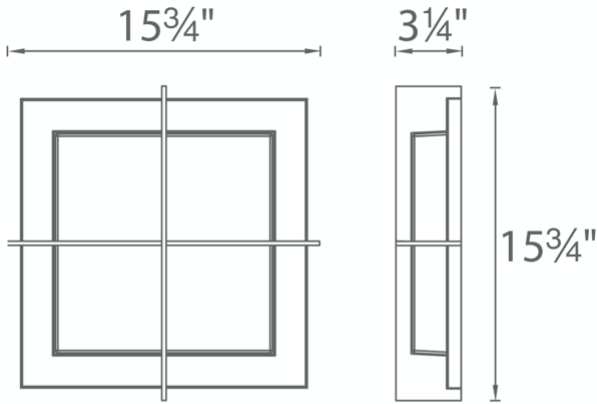

FM-4716-SS

Model & Size	Color Temp	Finish	LED Watts	LED Lumens	Delivered Lumens
FM-4716 16"	3000K	SS Stainless Steel	40W	2800	1160

Example: **FM-4716-SS**

For custom requests please contact customs@modernforms.com