



1718 W. Fullerton Chicago, IL 60614  
 Ph: 773.770.1195 • Fax: 773.935.5613  
 www.PureEdgeLighting.com • info@PureEdgeLighting.com  
 © 2016 PureEdge Lighting. All Rights Reserved.

## Installation Instructions for Tie Stix Wall 2-Light Tunable White with Remote Power

TXW2R-\_\_-2K4K-\_\_

### IMPORTANT INFORMATION

- This product is ETL listed.
- This instruction shows a typical installation.
- This product is wall mount only.
- The 4SQ version mounts to a standard junction box with plaster ring or octagon box.
- The 1RE version mounts to the provided Slim Profile Junction Box.
- The 2RE version mounts to a single gang box.

**SAVE THESE INSTRUCTIONS!**

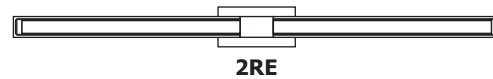
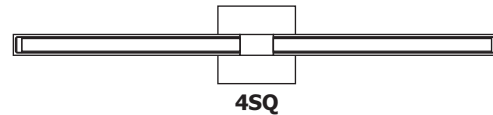

### Section One: 4SQ Version

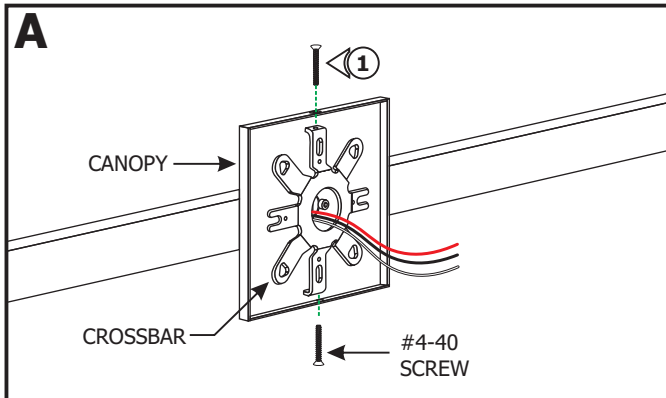

**NOTE:** Before beginning any electrical work, ensure that the power to the junction box is off.

- 1:** Remove the two #4-40 screws from the canopy using a 1/16" Allen wrench to remove the crossbar.

**NOTE:** Omit steps 2 through 6 if using dimming module for two channel controls. Refer to wiring diagram on page 6.

- Use the "Low Voltage Wire Size Chart" on Page 2 to determine proper wire size connecting to the DMX controller terminals.
- Run the proper size red, black and white wires from the fixture to the power supply enclosure.
- Connect the red fixture wire to the red "+" DMX terminal and tighten the screw.
- Connect the black fixture wire to the red "-" DMX terminal and tighten the screw.
- Connect the white fixture wire to the green "-" DMX terminal and tighten the screw.

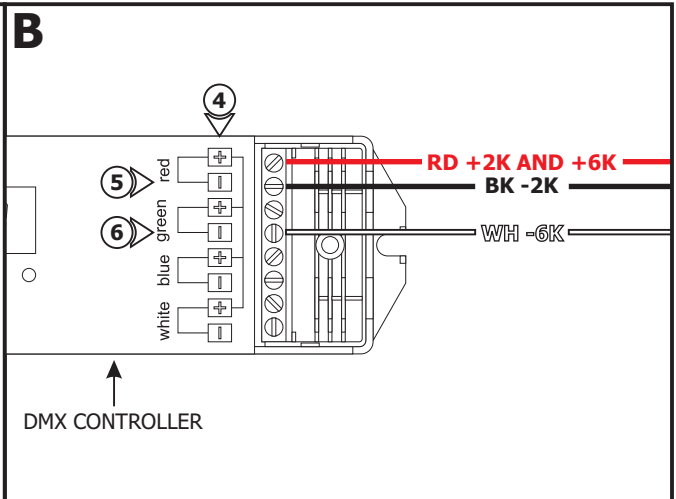

100W, 24VAC LOW VOLTAGE WIRE SIZE CHART					
3% VOLTAGE DROP	WIRE LENGTH IN FT	UP TO 31FT	32FT-49FT	50FT-81FT	82FT-124FT
	WIRE SIZE	14 AWG	12 AWG	10 AWG	8 AWG
	VOLTAGE AT END OF THE WIRE	23.28 VAC	23.29 VAC	23.28 VAC	23.28 VAC

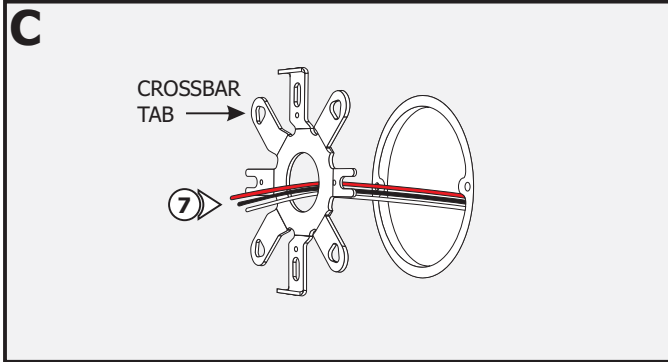

**7:** Feed the wires coming from the DMX controller or dimming module through the center hole of the crossbar. Refer to the instructions provided with the power supply.

**8:** Align the crossbar tabs vertically and mount the crossbar to the junction box holes with the two #8-32 screws provided.

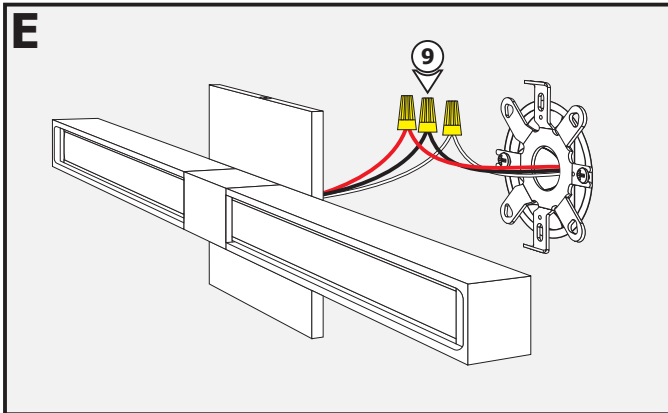
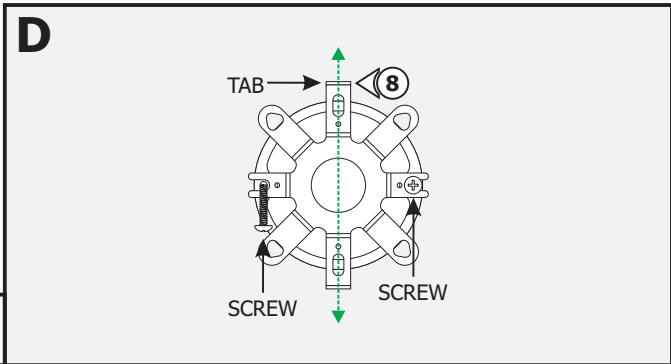

**9:** Refer to the wiring diagrams on pages 5 and 6 to connect the wires properly.

**10:** Place all the wires and wire connections inside the junction box.

**11:** Place the fixture against the crossbar and secure it with the provided #4-40 screws using a 1/16" Allen wrench.

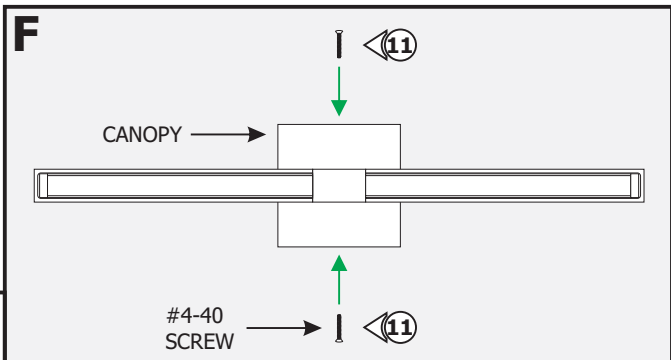

## Section Two: 1RE Version

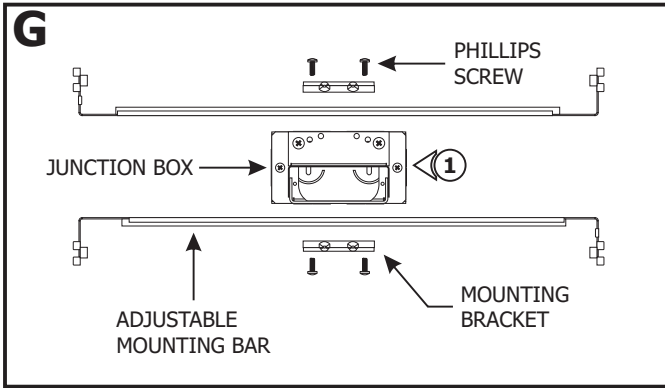

**NOTE:** Before beginning any electrical work, ensure that the power to the electrical box is off.

- 1:** Mount each adjustable mounting bar to one side of the junction box and secure them with the provided mounting brackets and two Phillips screws.

**NOTE:** Adjustable mounting bars mount to studs that are spaced 15" to 25" apart. If the span needs to be shorter than 15", then break the bar arms from dedicated lines.

- 2:** Place the adjustable mounting bar tabs between the studs. Secure the adjustable bars to the studs with the #8 screws.

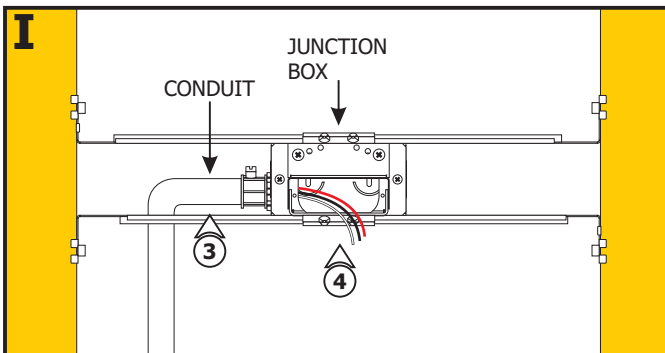
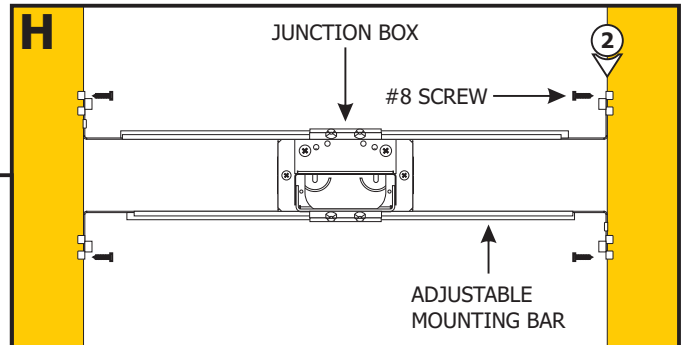

- 3:** Remove a knockout to install a conduit into the junction box. Install conduit(s) (if required by local electrical code).

- 4:** Run the wires coming from the DMX controller (refer to Drawing B, steps 2 through 6 on page 1) or dimming module for two channel controls to the junction box.

- 5:** Mark the rectangular junction box opening shape on the drywall where the junction box will be located.

- 6:** Cut out the marked rectangle opening, using a "Dremel Multi-Max" with the "wood & drywall" cutting bit.

- 7:** Install the drywall and plaster around the junction box. Sand and then paint.

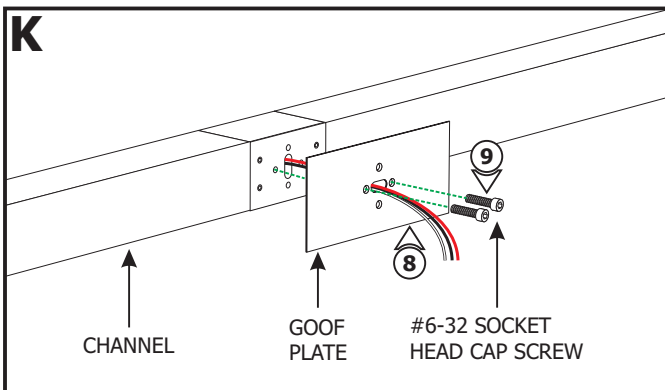
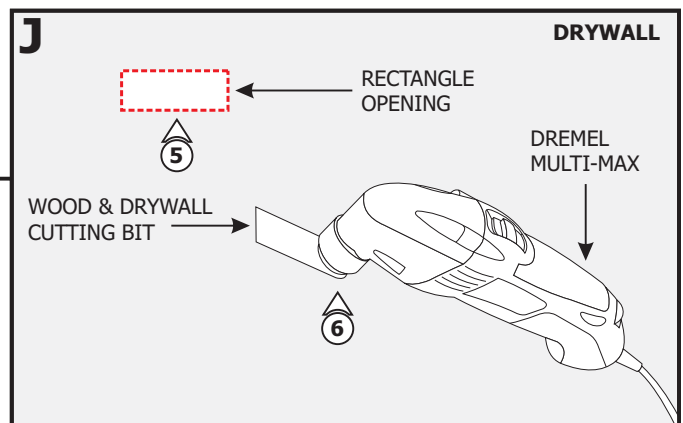

- 8:** Feed the wires of the channel through the goof plate.

- 9:** Place the provided goof plate (paint to match prior) onto the Tie Stix channel. Secure it with the two 1/2" #6-32 socket head cap screws using a 7/64" Allen wrench (provided).

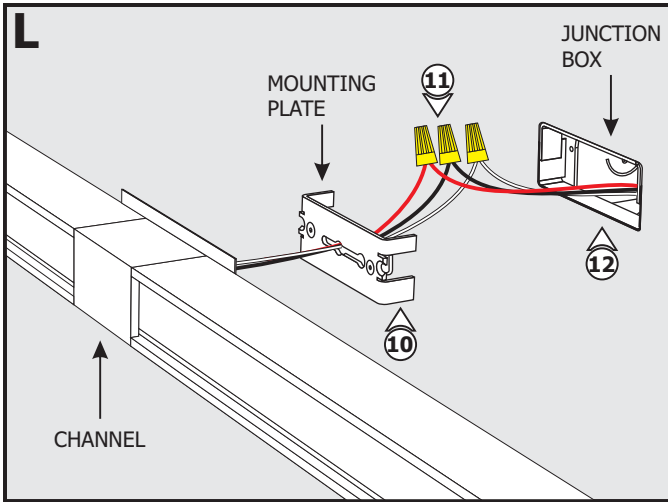

**10:** Feed the wires from the channel through the mounting plate.

**11:** Refer to the wiring diagrams on pages 5 and 6 to connect the wires properly.

**12:** Place all the wires and wire connections inside the junction box.

**13:** Place the mounting plate into the junction box. Secure it with the two Phillips screws.

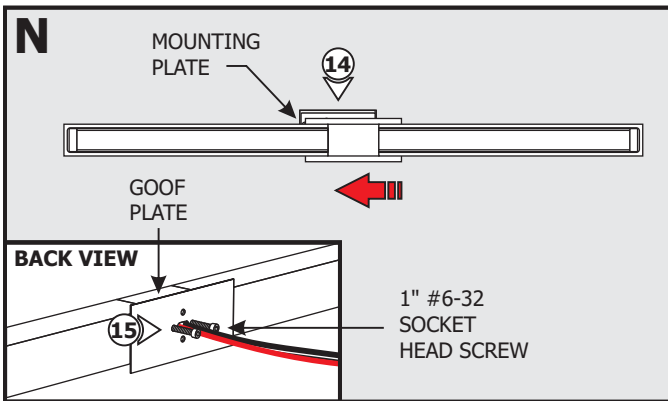
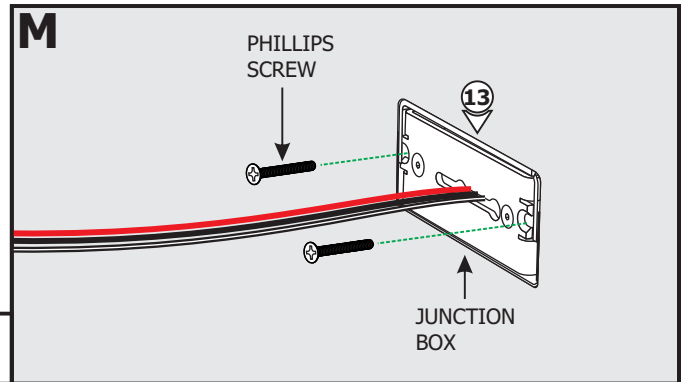

**14:** Insert the socket head cap screws into the opening of the mounting plate, then slide sideways to lock in place.

**15:** If the drywall is thicker than 3/4", use the two 1" #6-32 socket head cap screws (provided) for the goof plate with a 7/64" Allen wrench.

### Section Three: 2RE Version

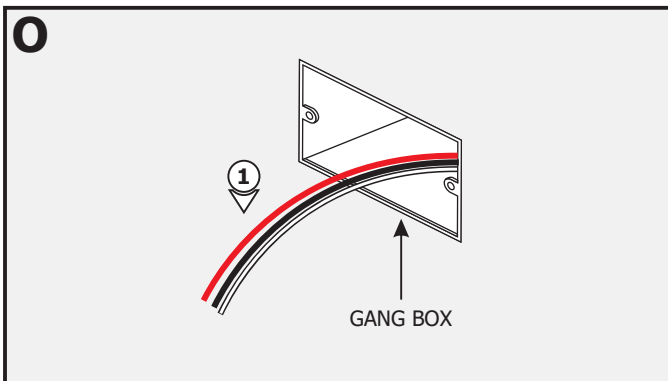

**NOTE:** Ensure single gang box is oriented horizontally.

**1:** Run the wires coming from the DMX controller (refer to Drawing B, steps 2 through 6 on page 1) or dimming module for two channel controls to the gang box.



# Tunable White: LED Power Supply with two Channel Controls, for Intensity and Color Temperature

