



1718 W. Fullerton Chicago, IL 60614
 Ph: 773.770.1195 • Fax: 773.935.5613
 www.PureEdgeLighting.com • info@PureEdgeLighting.com
 © 2016 PureEdge Lighting. All Rights Reserved.

Installation Instructions for **Sail LED - Tunable White with DMX**

SAIL-LED-DMX-2K6K

IMPORTANT INFORMATION

- This product is wall mounted only.
- Supply power to mirror in accordance with local electrical codes.
- This instruction shows a typical installation.
- This product must be installed by a qualified electrician.

SAVE THESE INSTRUCTIONS!

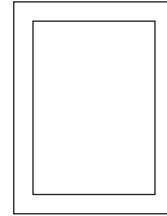

Install the Fixture

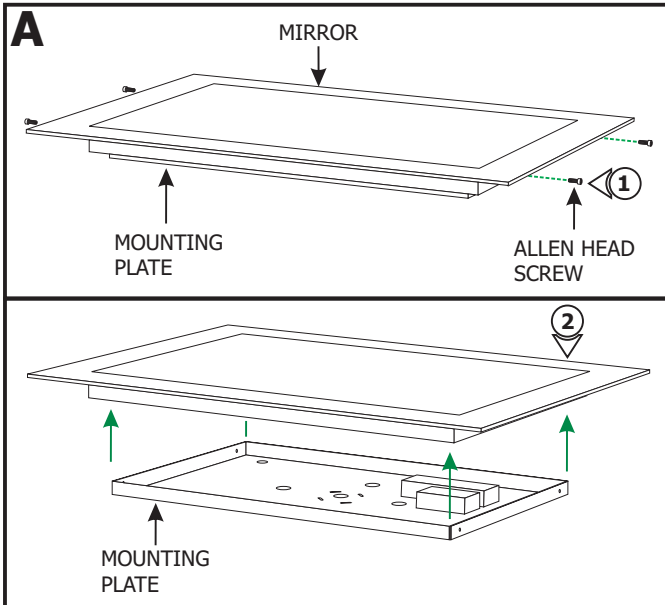

NOTE: It is recommended that one person holds the mounting plate while the electrician installs it.

- 1: Loosen and remove the four Allen head screws on the top and bottom of the mounting plate with an Allen wrench.
- 2: Pull the mounting plate completely out of the mirror.

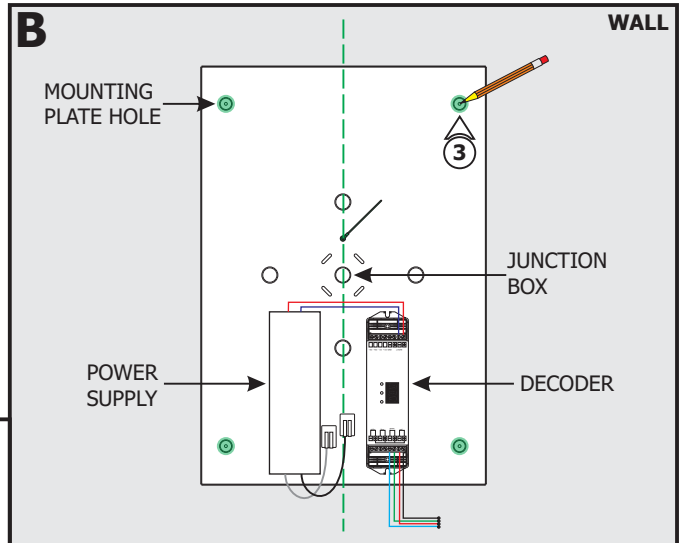

NOTE: Make sure that the mounting plate is leveled.

- 3: Using the mounting plate as a template, mark four mounting holes (highlighted in GREEN) onto the wall.

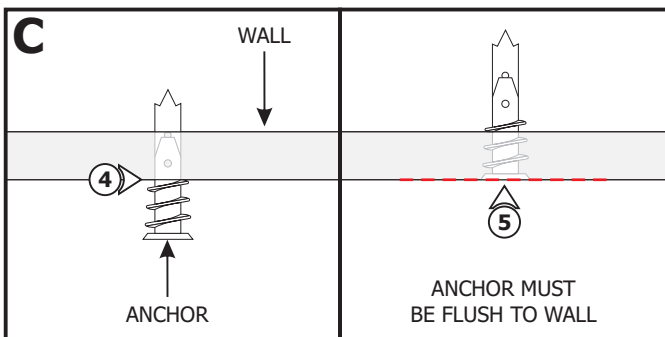

- 4: Tap the anchors onto the marked locations up to the threaded portion with a hammer.
- 5: Screw in the threaded portion of the anchors with a Phillips screwdriver.

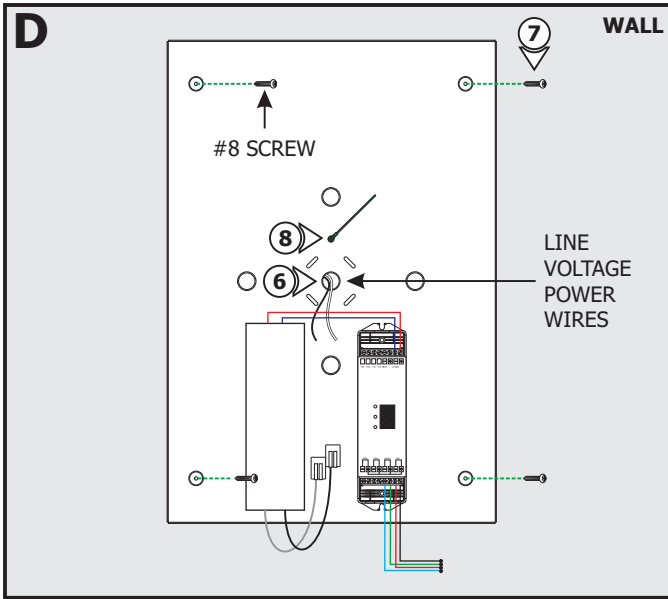

6: Feed the line voltage power wires through the mounting plate using 1/2" knockouts and appropriate connectors in accordance with local electrical codes.

7: Line up the mounting plate holes with the anchors and secure it with the four #8 screws provided.

8: Ensure the mounting plate is grounded in accordance with local electrical codes.

NOTE: Contains integrated 24V LED lights consuming a total of 76 Watts.

- 9:** On the lever nut that the black power supply wire is connected, pull up an available lock lever and insert the hot line wire. Press the lever down to connect and lock in place.
- 10:** On the lever nut that the white power supply wire is connected pull up an available lock lever and insert the neutral line wire. Press the lever down to connect and lock in place.

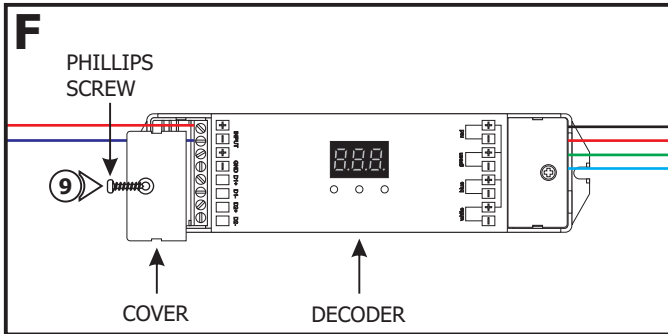
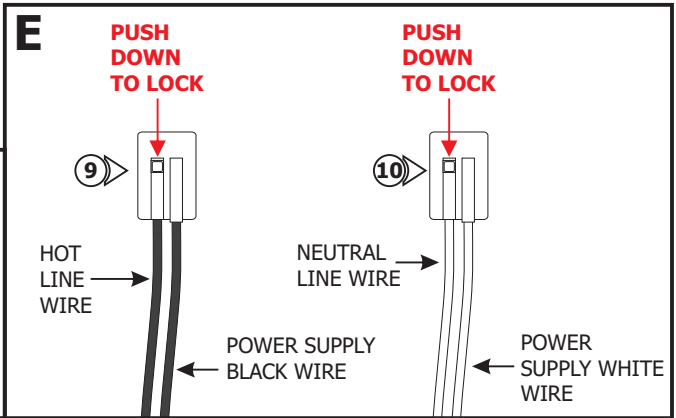

11: Loosen the Phillips screw on the input side of the decoder to remove the cover.

NOTE: To install the controller & run the DMX wires to the decoder prior to the steps below, refer to the instructions provided with the controller. Use the Programming Guide on Page 3 to set the decoders.

- 12:** Loosen the screws on the "GND," "D1+," and "D1-" terminals of the DMX decoder with a flat head screw driver.
- 13:** Insert the end of the first data wire (blue with white stripes wire) into the "D1-" DMX terminal and tighten the screw.
- 14:** Insert the end of the second data wire (white with blue stripes wire) into the "D1+" DMX terminal and tighten the screw.
- 15:** Insert the end of the third data wire (bare shield wire) into the "GND" DMX terminal and tighten the screw.

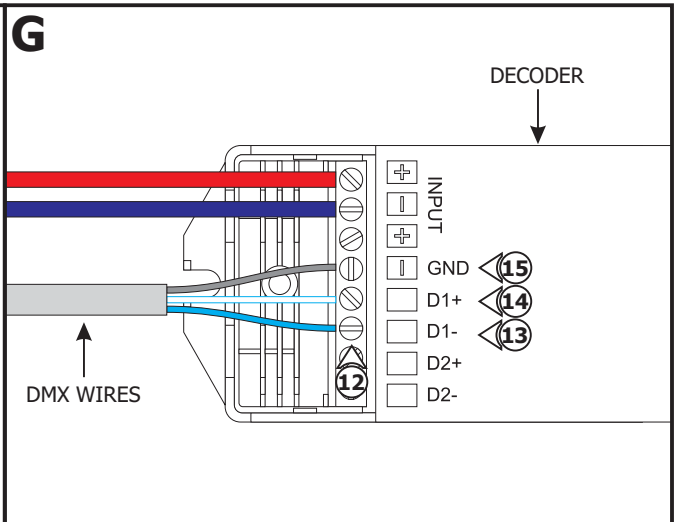

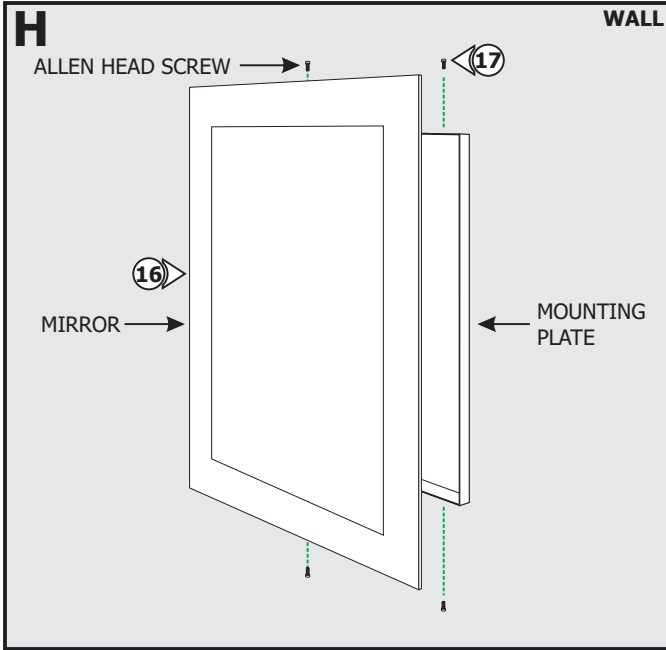

16: Carefully place the mirror onto the mounting plate.

17: Secure the mirror to the mounting plate by tightening the four Allen head screws using an Allen wrench.

Decoder Programming Guide

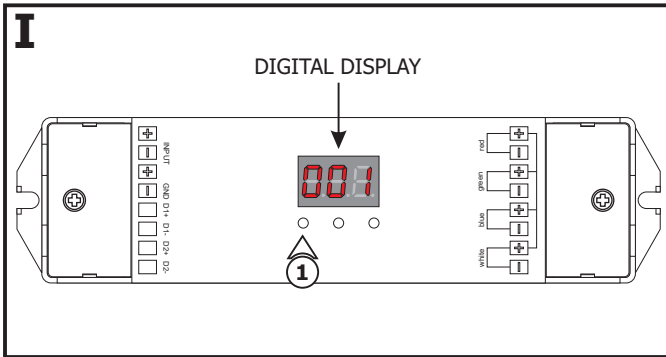

1: Press and hold the first button for two seconds until the digital display flashes to choose a DMX address.

2: Use the three buttons to set the DMX address.

3: Press and hold any button for two seconds to confirm.

4: Press and hold the second and third buttons at the same time for two seconds until the digital display flashes to choose a channel.

5: Press the first button to toggle the channel to 2.

6: Press and hold any button for two seconds to confirm.

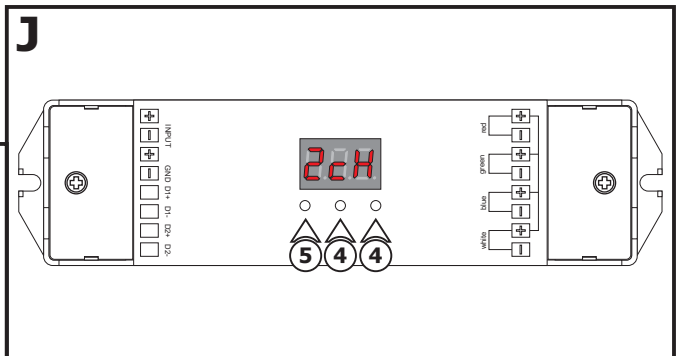

7: Press and hold the first and third buttons at the same time for two seconds until the digital display flashes to enter the PWM frequency settings.

8: Press the first button and toggle to 2, meaning 200Hz. Press the third button and toggle to 2, meaning linear dimming.

9: Press and hold any button for two seconds to confirm.

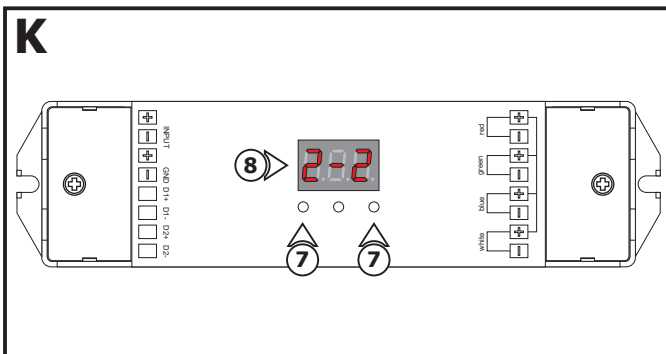

General Wiring Diagram

