



1718 W. Fullerton Chicago, IL 60614  
 Ph: 773.770.1195 • Fax: 773.935.5613  
 www.PureEdgeLighting.com • info@PureEdgeLighting.com  
 © 2016 PureEdge Lighting. All Rights Reserved.

## Installation Instructions for **Piston**

FJ-PST-\_\_

### IMPORTANT INFORMATION

- This instruction shows a typical installation.
- This product is intended to be used with PureEdge Lighting Monorail and Fast Jack systems only.

**SAVE THESE INSTRUCTIONS!**

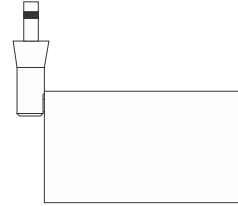

## Install the Fixture to Monorail Connector

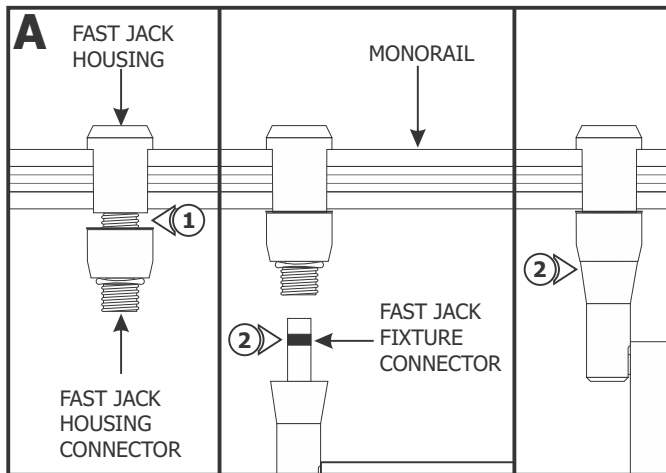

- 1: Place the Fast Jack housing onto the Monorail and use fingers to tighten the Fast Jack housing connector to the Fast Jack housing. **Make sure that the Fast Jack housing connector is not cross threaded.**
- 2: Use fingers to tighten the Fast Jack fixture connector into the Fast Jack housing connector.

## Install the Fixture to Monorail 2 Circuit Connector

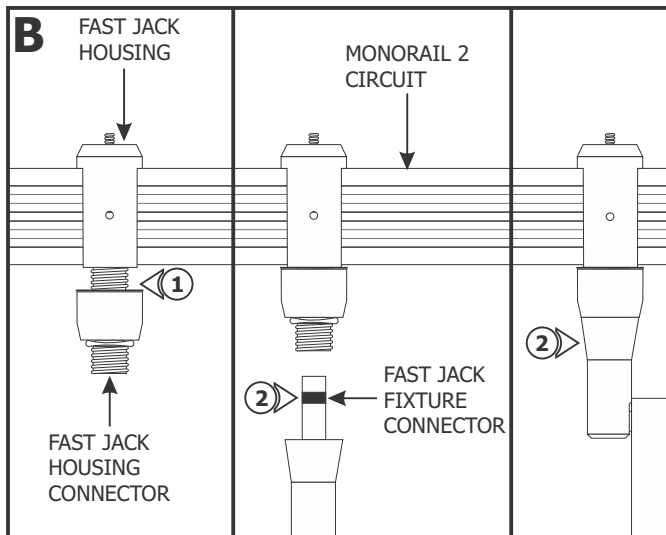

- 1: Place the Fast Jack housing onto the Monorail 2 Circuit and use finger to tighten the Fast Jack housing connector to the Fast Jack housing. **Make sure that the Fast Jack housing connector is not cross threaded.**
- 2: Use fingers to tighten the Fast Jack fixture connector into the Fast Jack housing connector.

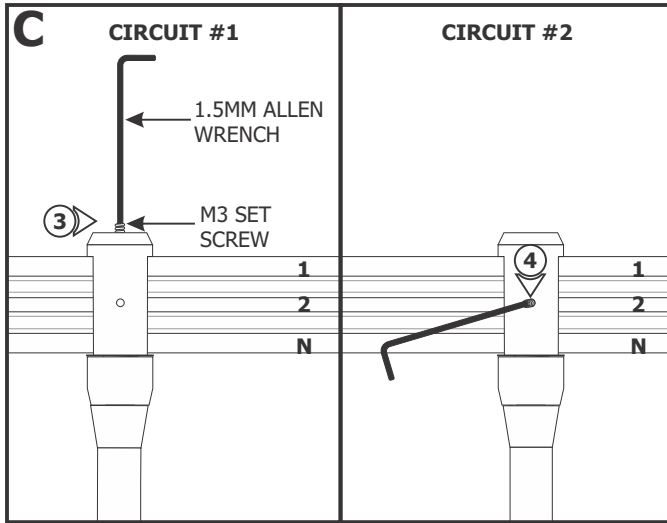

**3:** To power the fixture from circuit #1, top and bottom (neutral) rails, tighten the M3 set screw on top of the housing with the 1.5mm Allen wrench. **Make sure this set screw connection is very tight.**

**4:** To power the fixture from circuit #2, middle and bottom (neutral) rails, remove the M3 set screw from top of the housing and tighten it into the side threaded hole with the 1.5mm Allen wrench. **Make sure this set screw connection is very tight.**

**NOTE:** To avoid shorting the system, do not use more than one set screw to select a circuit on the Monorail 2 Circuit connector.

**NOTE:** Do not load either circuit over the maximum system rating.

## Install the Fixture to Fast Jack LED Single or Multiport Canopies

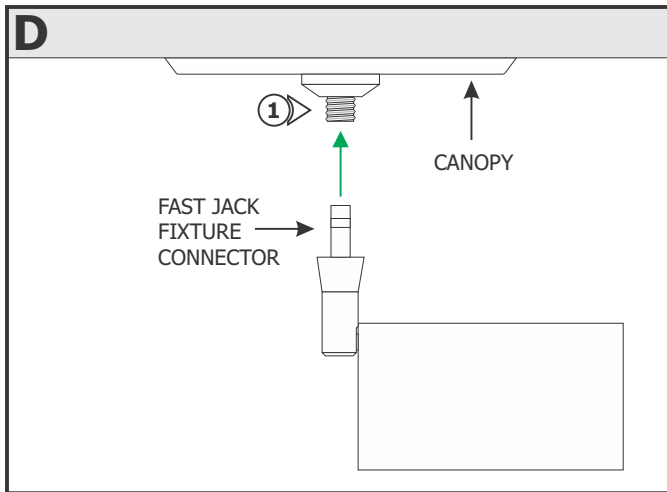

**1:** Use fingers to tighten the Fast Jack fixture connector into the Fast Jack Canopy connector.

## Adjust the Fixture

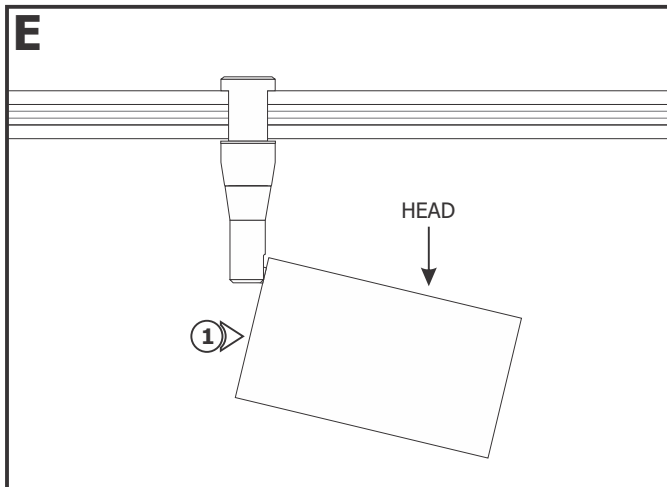

**1:** Rotate the fixture head to desired angle.

**NOTE:** The Piston contains an integrated LED lamp. Each fixture consumes **9** watts.