



© 2017 Edge Lighting. All Rights Reserved.

1718 W. Fullerton Ave
Chicago, IL 60614
Tel: 773-770-1195
Fax: 773-935-5613
www.edgelighting.com
info@edgelighting.com

LC45-____-____

Installation Instructions for **DIY** or **Completed 45 Degree Light Channel**

IMPORTANT INFORMATION

- This instruction shows a typical installation.

SAVE THESE INSTRUCTIONS!

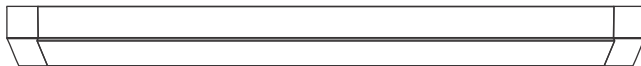

Section One: Assemble the Light Channel

A	WATTAGE	MAX STRIP LENGTH IN INCHES
	2.5 WATTS	480
	5 WATTS	240
	7.5 WATTS	144

NOTE: Omit Section One if the fixture is complete.

1: The maximum length of channel is 120". Use the chart to determine the number of channels needed based on soft strip wattage. If the amount of LED soft strip needed is greater than 120", two or more channels should be used.

NOTE: Do not trim the strip at unmarked sections which may cause that section of the strip to not light up.

2: Determine the amount of LED strip needed. Trim the LED strip at the marked line above the contacts with a sharp scissor.

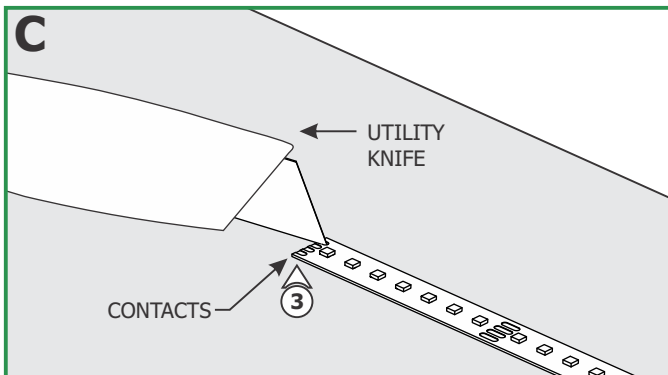
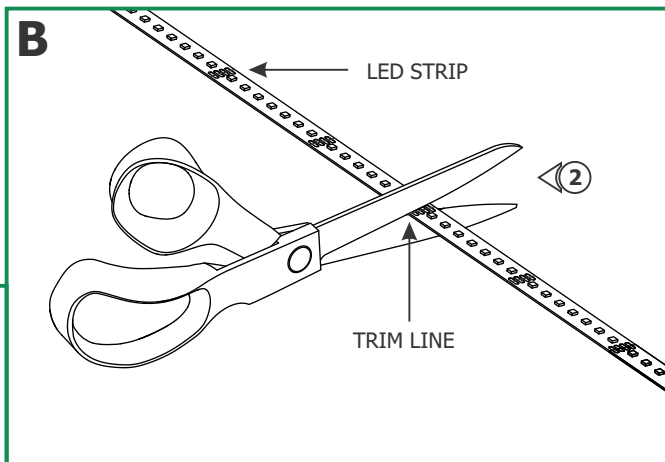

3: Place the LED strip on a flat, stable surface. Using a utility knife, carefully scrape the protective coating from the contacts on both ends.

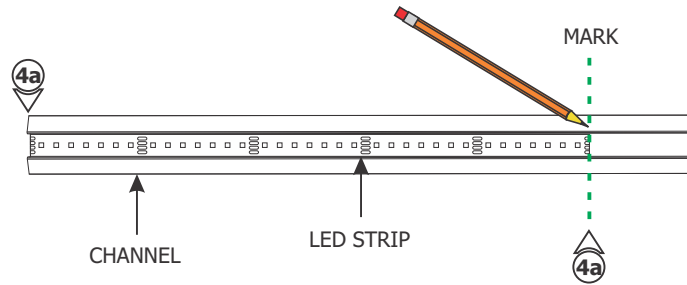
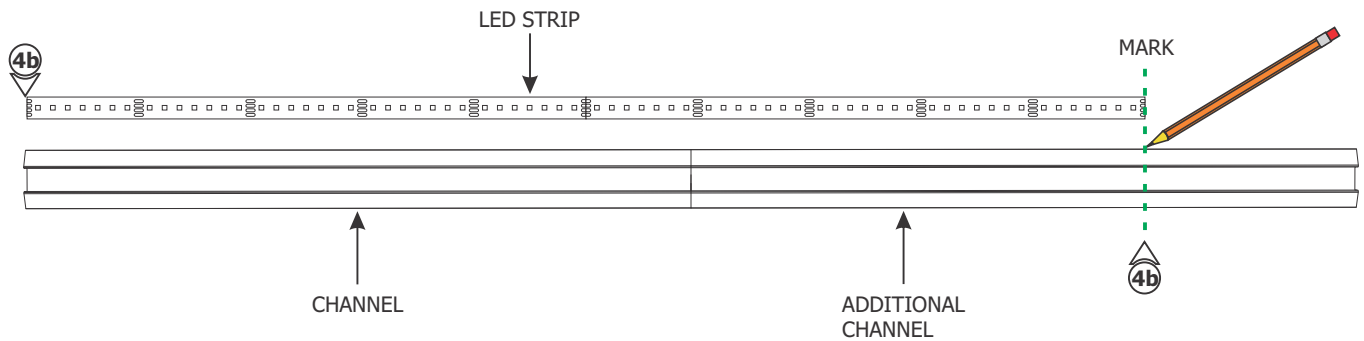
D**USING SINGLE CHANNEL****USING MULTIPLE CHANNELS**

4a: If using a single channel, lay the LED strip inside the single channel flush to one end and mark the length of the LED strip on the channel.

4b: For multiple channels, put the channels next to each other from one end to another. Lay the LED strip inside both channels flush to one end and mark the length of the LED strip on the channel.

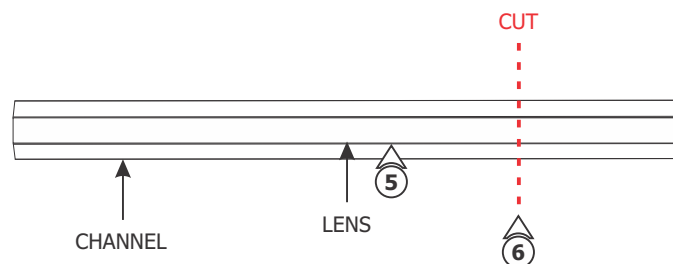
E

5: Remove the LED soft strip and snap the lens on the channel **BEFORE** cutting to length. This ensures a proper fit after installation.

6: To match the LED strip length, cut the channel and lens with a hack or chop saw.

NOTE: Clean the burs at the end with sandpapers.

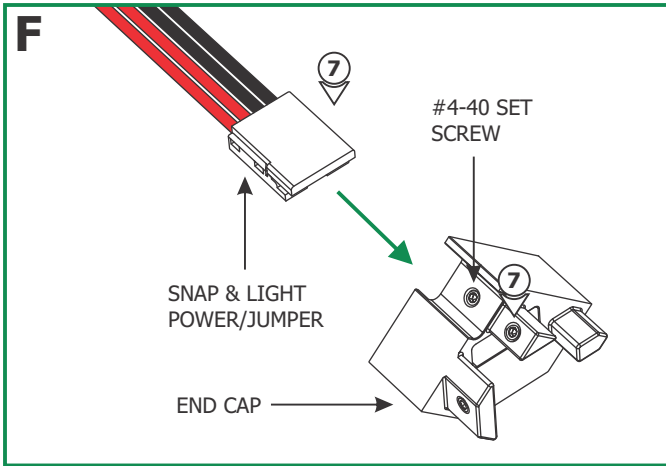

7: Loosen (**Do Not Remove**) the three #4-40 set screws on the end cap using a 0.05" Allen wrench. Insert the Snap & Light Power/Jumper connector through the end cap.

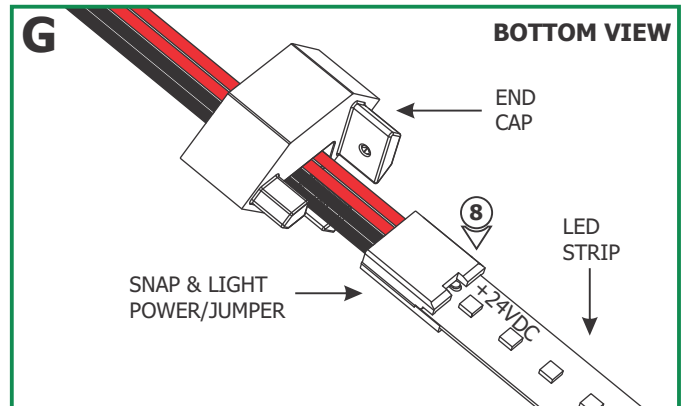

8: Insert the LED strip into one end of the Snap & Light Power/Jumper connector so that the "24VDC+" mark on the strip is aligned with the red wires. Ensure the LED strip contacts align fully with the contact pins. Push the LED strip completely into the contact pins.

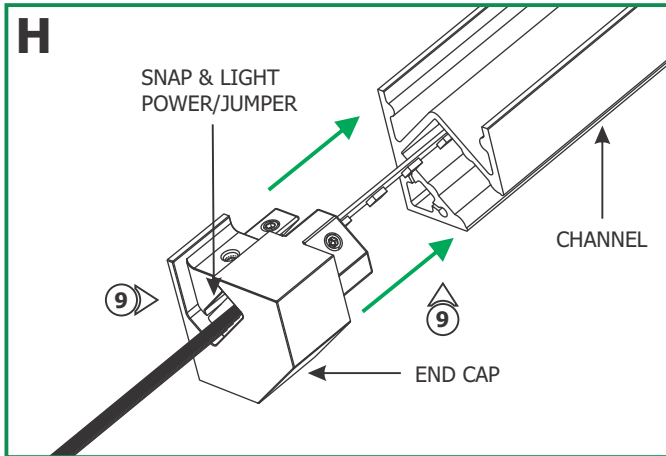
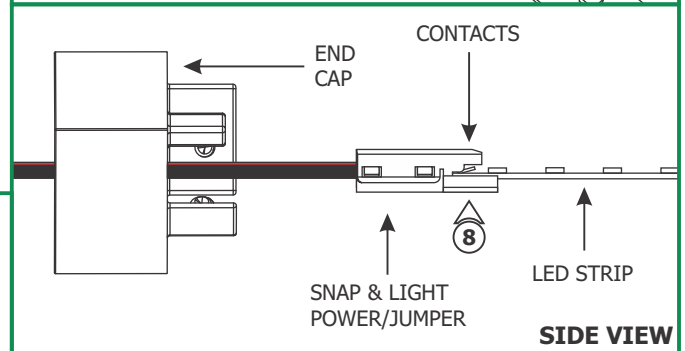

9: Insert the Snap & Light Power/Jumper connector inside the end cap and slide the end cap into the channel.

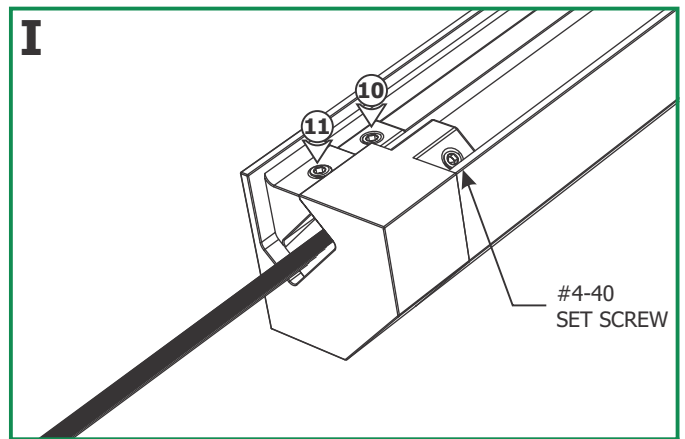

10: Secure the end cap to the channel by tightening the two #4-40 set screws using a 0.05" Allen wrench.

11: Secure the connector to the end cap by tightening the #4-40 set screw with a 0.05" Allen wrench.

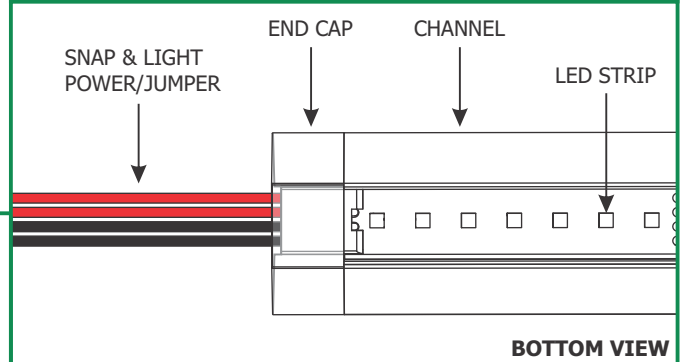

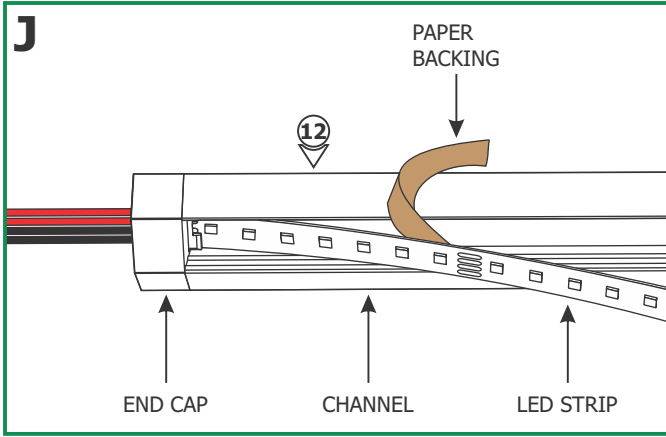

12: Carefully remove the backing from the LED strip, make sure not to remove the tape from the strip. Firmly press down the adhesive portion of the strip onto the channel surface while removing the rest of the backing, making sure there are no air bubbles that can cause surface irregularities.

NOTE: Refer to page 7 for important information regarding installation and rework of the LED strip.

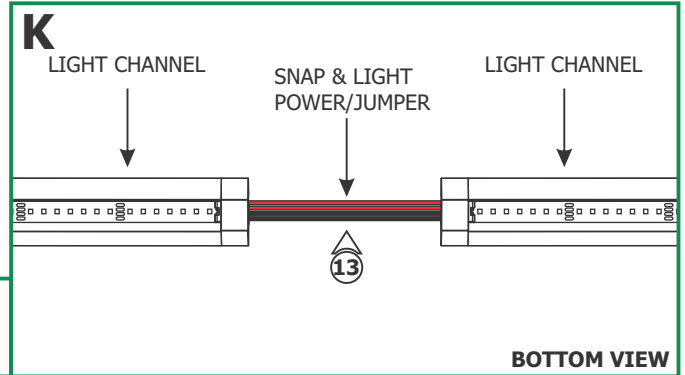

13: To power jump one light channel to the other repeat steps 7 through 12, otherwise follow step 10 to install the end cap.

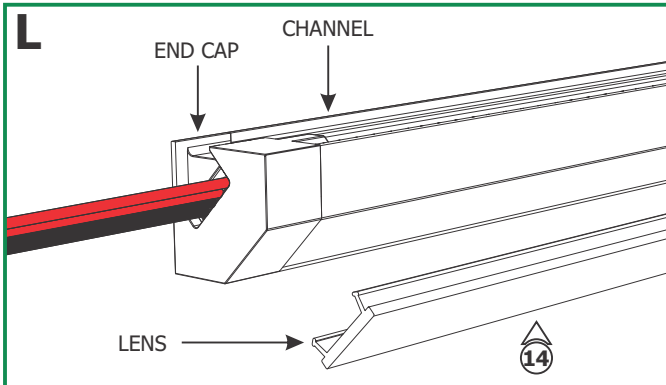

14: Snap the lens(es) to the assembled channel(s).

Section Two: Installing Light Channel Snap & Light Connectors

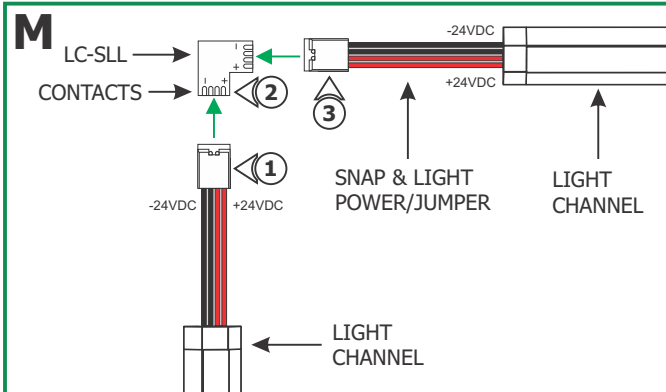

NOTE: Light Channel Snap & Light L-Connector (LC-SLL) is shown (sold separately).

- 1:** Insert the Light Channel Snap & Light Connector completely into the Snap & Light Power/Jumper Connector so that the "+" mark on the connector is aligned with the red wires.
- 2:** Ensure the contacts of the Snap & Light Connector align fully with the contact pins of the Power/Jumper Connector. Push the connector completely into the contact pins.
- 3:** Repeat steps 1 and 2 for each end of the Light Channel Snap & Light Connector.

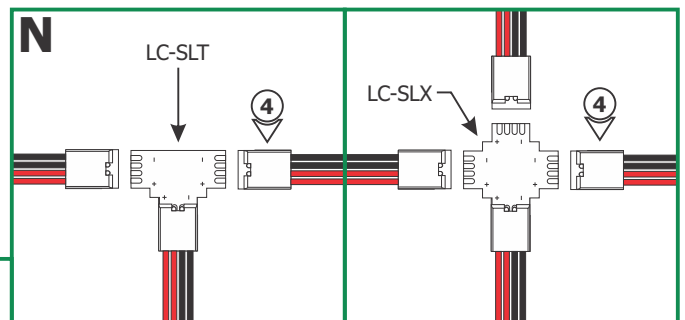

4: Refer to steps 1 through 3 if using the Light Channel Snap & Light X-Connector or T-Connector (sold separately).

Section Three: Install the Light Channel

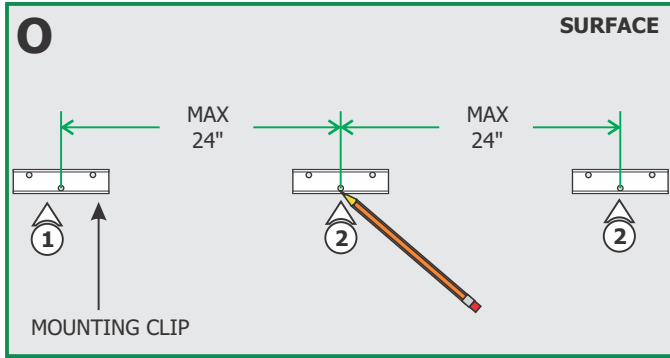

- 1: Determine the location of the 45 Degree Light Channel.
- 2: Mark the location of the mounting clips evenly on a straight line. Mounting clips must be maximum 24" apart from each other.

NOTE: Steps 3 through 5 are for drywall mounting. Omit these steps if mounting the clips to a wood surface directly.

- 3: Tap the anchors onto the marked points up to the threaded portion with a hammer.
- 4: Screw in the threaded portion of the anchors with a Phillips screwdriver.

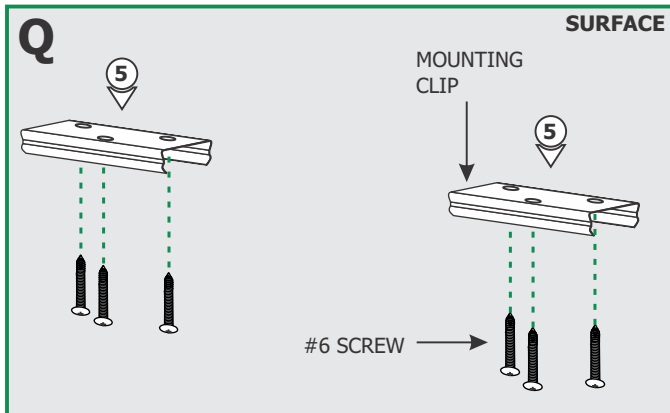
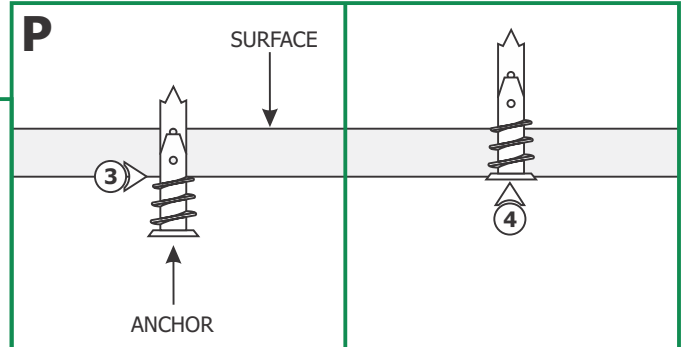

- 5: Line up the mounting clips to the anchors and secure them to the anchors by tightening the three #6 screws.

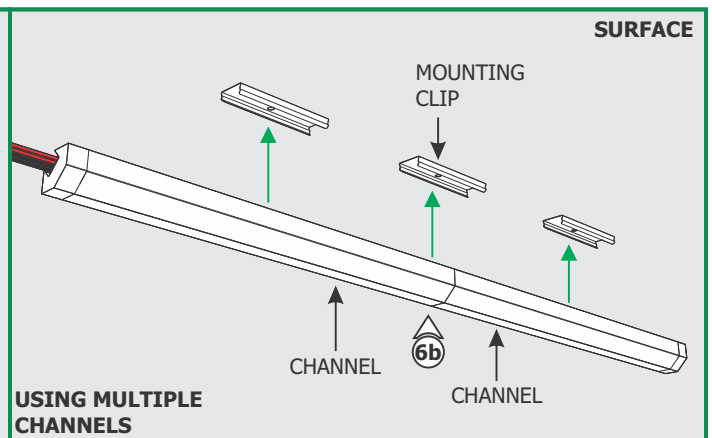
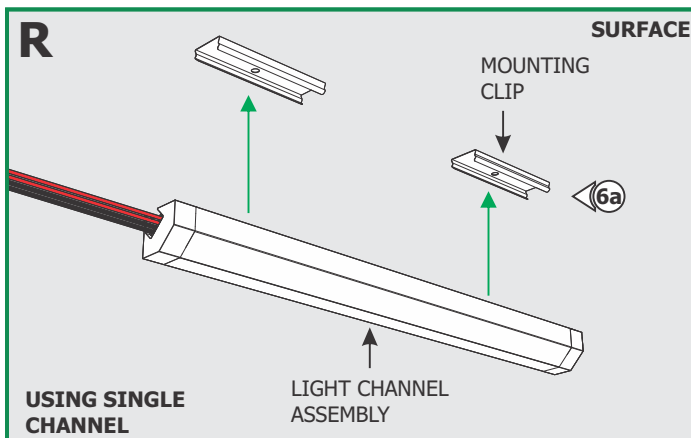

6a: Snap the light channel assembly to the mounting clips.

6b: For multiple channels, ensure that a mounting clip is in the center where the channels meet together.

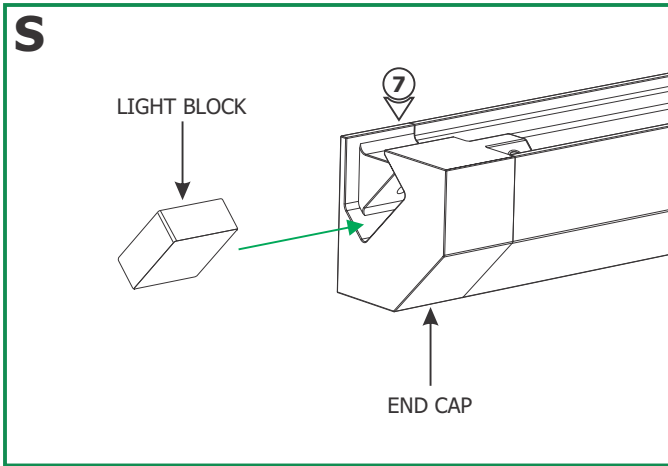

7: Insert the light block into the end cap. Secure the light block by tightening the #4-40 set screw using a 0.05" Allen wrench.

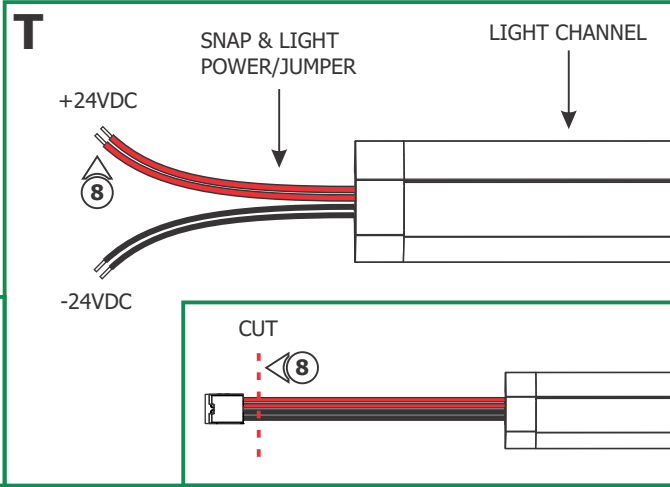

8: Cut the end of the power cord that is going to be connected to power and discard the unused connector. Strip the ends of the wires.

NOTE: Follow the instructions provided with the power supply to power the light channel.

General ELV Wiring Diagram

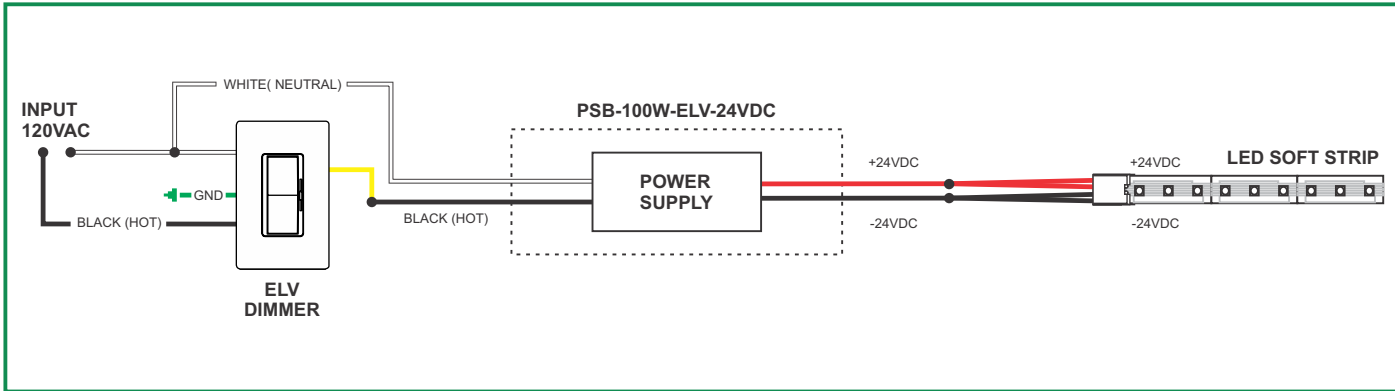

General 0-10 Wiring Diagram

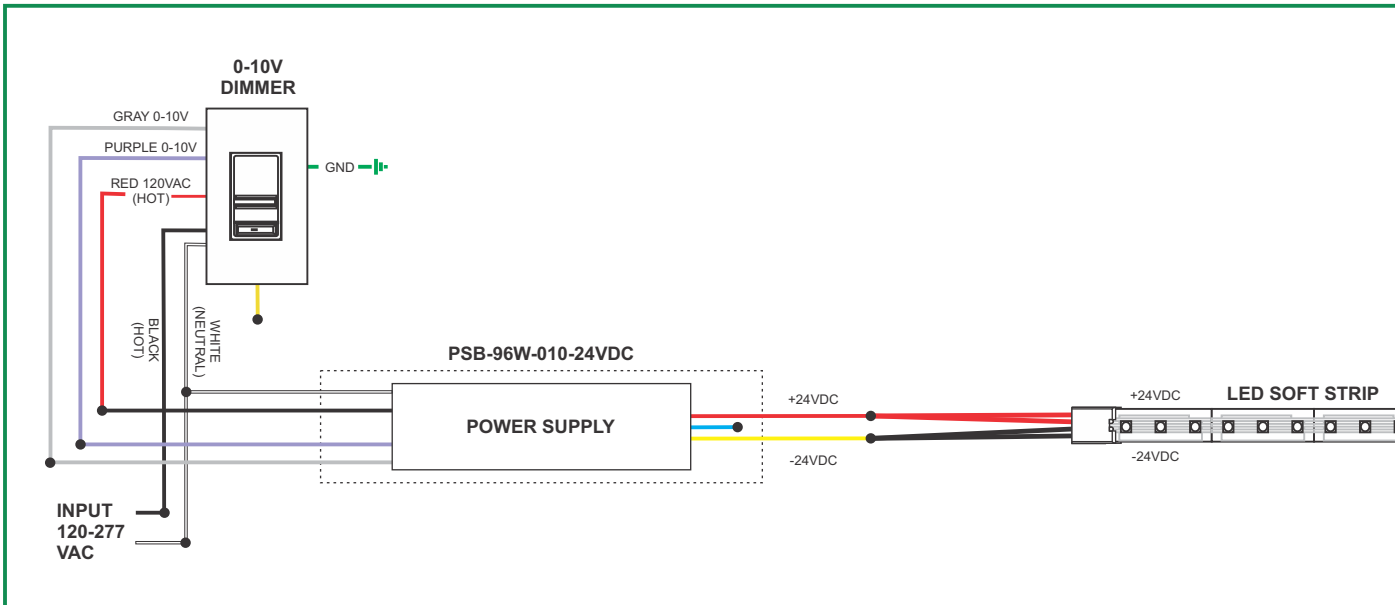

IMPORTANT INFORMATION REGARDING INSTALLATION AND REWORK OF SOFT STRIP LED

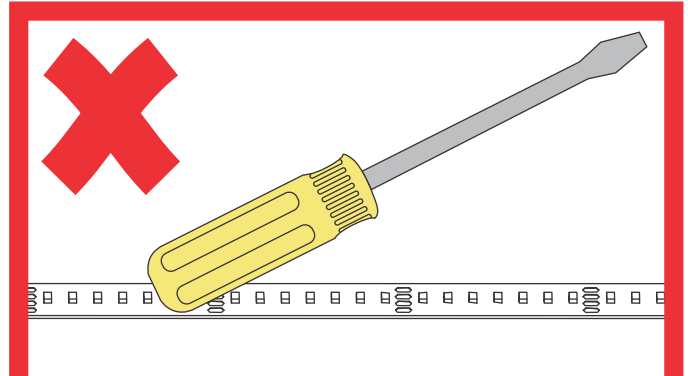
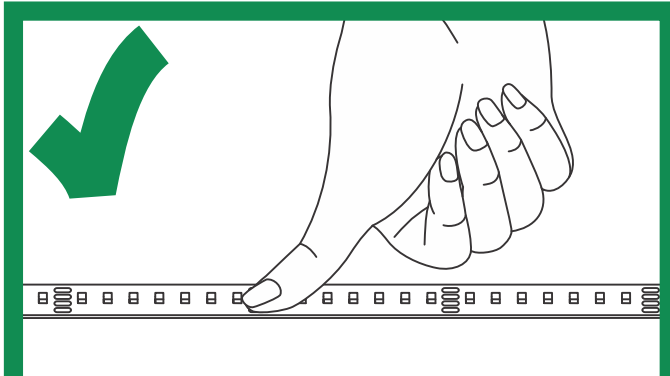
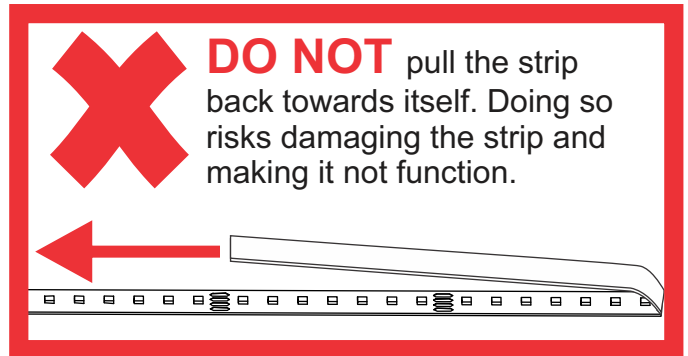
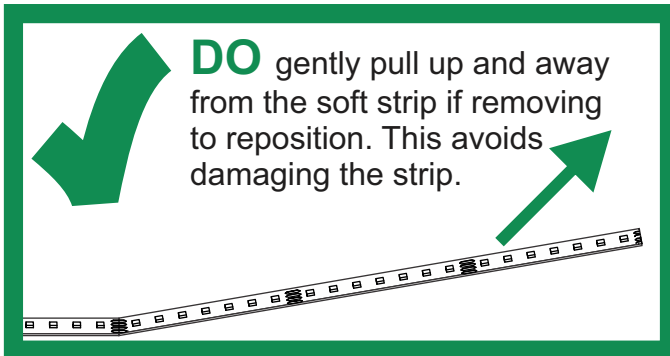

Relocating Soft Strip (Optional)

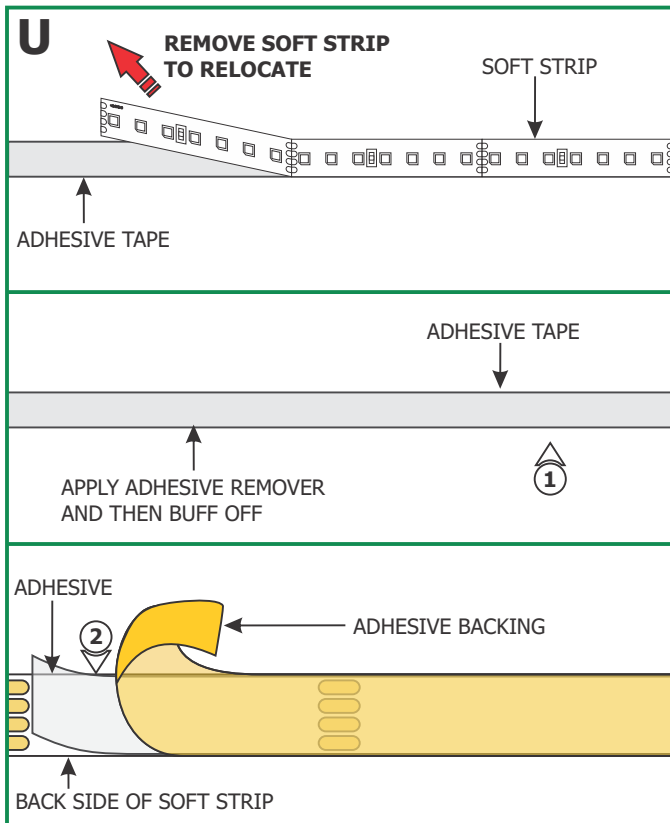

NOTE: If relocating the installed soft strip, make sure that the adhesive tape on back of the soft strip covers the entire strip. The adhesive tape isolates the strip from the installation surface. Damaged or inconsistent adhesive tape may cause the contacts on the back of the strip to come in contact with the conductive heat sink which will cause the strip to short and burn. Call Edge Lighting to get replacement adhesive tape and/or optional aluminum heat sink tape (SS-HR-F).

- 1:** To remove tape residue from back of the strip, apply WD-40, Goo Gone, or a mixture of warm water and lemon oil to the corner of a clean, dry towel. Gently buff the area containing the adhesive residue until it is completely removed.
- 2:** Gently remove a few inches from one side of the tape backing. Attach the adhesive tape to the back of the soft strip and apply moderate pressure to affix the tape. Continue this step a few inches at the time until the entire adhesive tape is attached to back of the soft strip.
- 3:** Refer to steps 8 through 12 in Section One to reinstall the soft strip.