

# Task Table & Floor Light

## Instruction Manual

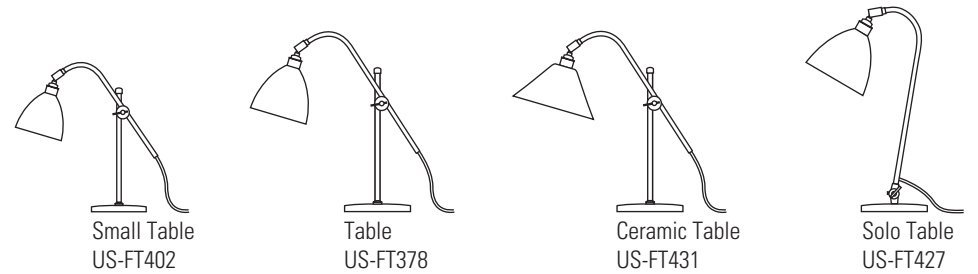

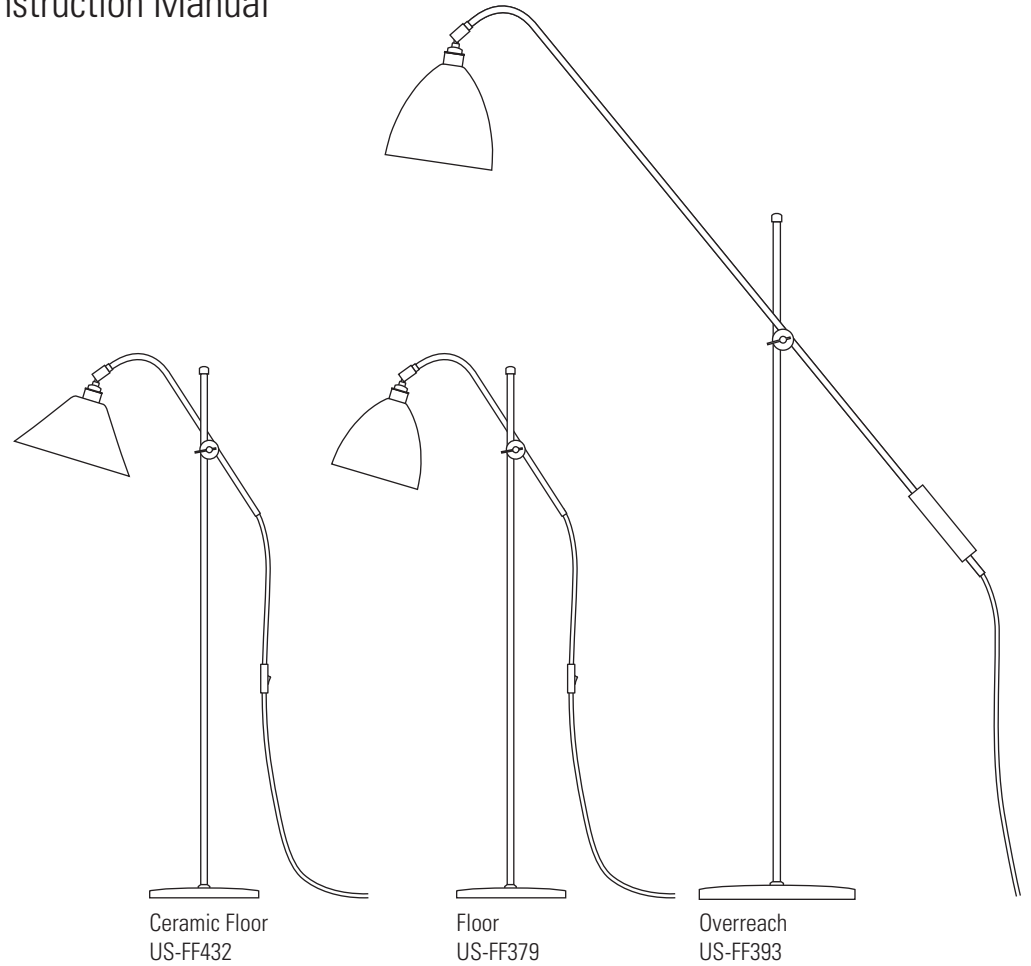

Established in 1990, Original BTC manufactures relaxed, familiar lighting for traditional and contemporary homes.  
All products are hand-assembled in Oxford from high quality components, produced in the UK.

# Task Table Light

| 120V ac 60Hz | IP20 |

US-FF432	Ceramic Floor	US-FT402	Small Table
US-FF379	Floor	US-FT378	Table
US-FF393	Overreach	US-FT431	Ceramic Table
		US-FT427	Solo Table

The Task range of lights can be moved, angled or adjusted bringing greater flexibility and creative scope, while focussing a high level of illumination directly where it is needed. Shades can be angled and swivelled, to throw either a concentrated pool or illuminate a larger area.

LAMP GUIDANCE					
BASE	SHAPE	TYPE*	WATTAGE**		
	 	INCANDESCENT ✓	60W MAX (a)	100W MAX (b)	
E26	A BALL	CFL ✓	15W	20W	
		ECO-HALOGEN ✓	42W	70W	
		LED ✓	10W	18W	

(a) US-FF432/379, US-FT402/378/431/427  
 (b) US-FF393  
 \* Warm white (2700k) low energy lamps recommended.  
 \*\* Wattage value provided as a guide to suitable lamps. Lower wattage than stated may be used.

## Safety Instructions

ENG WARNING – RISK OF FIRE AND ELECTRIC SHOCK.  
 SUITABLE FOR DRY LOCATIONS ONLY

FR ATTENTION – RISQUE D'INCENDIE, RISQUE DE CHOC.  
 POUR EMPLACEMENTS SECS SEULEMENT

- Ensure the lamp type and max wattage is followed- do not exceed. Take care not to overtighten lamp.
- Do not touch the lamp (bulb) or lamp holder while in operation, as both become very hot.
- Turn off and unplug fitting, leaving lamp to cool before changing lamp. Dispose of old lamps carefully.
- Adjust light fitting only when power to the fitting is off and has been left to cool.
- Never leave a fitting without a lamp in position.
- Keep light fitting away from combustible materials such as soft furnishings.
- Ensure children do not play with the light fitting.
- Ensure the light is positioned on a solid, level and non-slip surface and make sure the position of the cable does not pose a trip hazard.
- If the electrical flex or electrical components become damaged at any point, the fitting must be unplugged from the power supply immediately and not operated until the damaged parts are fixed/replaced.
- For use in a dry, indoor environment only. Ensure the fitting does not come into contact with any liquids.

## Cleaning and Maintenance

Metal finishes should only be cleaned with a soft, dry cloth. Do not use polishes or abrasives. Bone china can be cleaned by hand, using a soft damp cloth with a diluted mild detergent (nonabrasive) if necessary. Switch off power to the fitting before cleaning.

## Adjusting Fitting

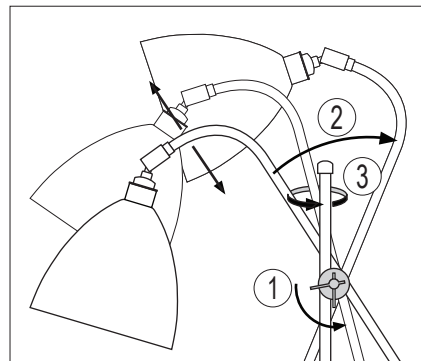

### Adjusting Position of Arm

- 1 Loosen the handle of the clamp, by gently turning clamp by one quarter-turn in an anti-clockwise direction.
- 2 Position arm into desired position, then secure by tightening handle of clamp firmly. Do not overtighten.
- 3 The arm may be rotated, when held in the clamp by gently twisting the arm while holding the clamp in position.

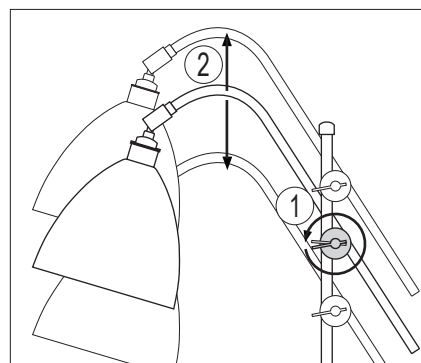

### Adjusting Height of Arm

- 1 Loosen the handle of the clamp, by gently turning clamp almost one full turn in an anti-clockwise direction.
- 2 While supporting both clamp and arm, position arm at desired height, then secure by tightening handle of clamp firmly. Do not overtighten.

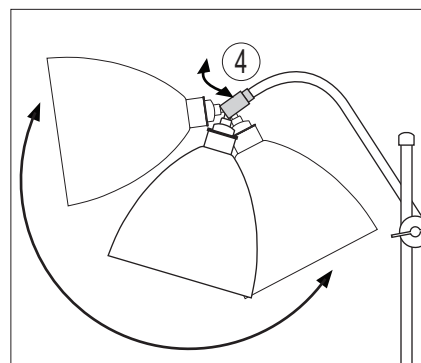

### Adjusting Shade

- The swivel joint allows great flexibility of movement, allowing the shade to be tilted or rotated into position as desired.
- Adjust angle of shade by gently pivoting shade on swivel joint (4)- tilting up/down up to 90° or rotating up to 180° in either direction.



When adjusting the clamp, ensure it is supported with other hand and take care not to loosen the handle too far, as this can cause the handle to detach from the clamp body and fall from the fitting, causing damage/injury.