

Safety & Installation Instructions

v1.1-06.19

ENG WARNING – RISK OF FIRE AND ELECTRIC SHOCK. THIS PRODUCT IS BEST INSTALLED BY A QUALIFIED ELECTRICIAN. INSTALL IN ACCORDANCE WITH CURRENT NEC WIRING REGULATIONS.

SUITABLE FOR DAMP LOCATIONS

THE FITTING MUST BE GROUNDED. TURN OFF POWER AT THE MAIN FUSE BEFORE COMMENCING INSTALLATION.

FR ATTENTION – RISQUE D'INCENDIE, RISQUE DE CHOC.

CE PRODUIT DOIT ÊTRE INSTALLÉ SELON LE CODE D'INSTALLATION PERTINENT, PAR UNE PERSONNE QUI CONNAÎT BIEN LE PRODUIT ET SON FONCTIONNEMENT AINSI QUE LES RISQUES INHÉRENTS.

CONVIENT AUX EMPLACEMENTS HUMIDES

L'APPAREIL DOIT ÊTRE MIS À LA TERRE. COUPEZ LE FUSIBLE PRINCIPAL AVANT DE COMMENCER L'INSTALLATION.

- 1 Ensure that the electrical supply is OFF. Disconnect the electrical supply at the fuse-board.
- 2 If removing an existing fitting first, note all wiring connections: record which of the house wires is connected to the live (hot), neutral and earth (ground) terminals.
- 3 Carefully identify where the supply cable is (and check there are no other cables in the area) to avoid damage to concealed wiring during installation.
- 4 Position the light where desired ensuring that there is access to a suitable junction box for the fixture and suitable support adjacent to where you will connect to the house supply. It may be possible to fit the luminaire directly to the junction box with the existing screws, if this is not the case mark and drill suitable holes as described below:
 - a. Brick or masonry: Drill holes into which the wall plugs tightly fit, then insert wall plugs.
 - b. Wood: No hole necessary (unless small pilot hole required), screws can be screwed directly into the timber.
 - c. Plaster/Cavity: Special cavity wall fittings are required, rather than provided fixings.
- 5 This fitting is supplied unwired. Connect the main supply from your junction box directly to the terminals on the lampholder. Open your junction box and connect the live (hot) black wire to the live terminal and the neutral white wire to the neutral terminal. Connect the bare copper or green/yellow ground wire to the earth (ground) terminal.

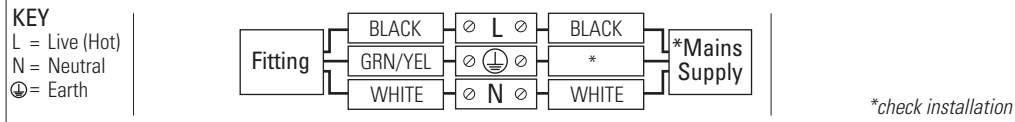

- 6 Support the fitting so that no strain is applied to the wiring when making the electrical connections.
- 7 Double check all the connections are secure, no wires are trapped behind or within the fitting and complete the installation, screwing the fitting to the wall, over your junction box.
- 8 Fit the correct type and wattage of bulb, referring to guidance inside. Do not overtighten bulb.
- 9 Switch on at the fuse-board. Your light fitting is now ready for use.

Other Important Information

Switch off at mains before changing lamp(s). Never fit a lamp of greater wattage than recommended. Ensure children do not play with the light fitting. Dispose of old lamps carefully. Never leave a fitting without a lamp in position (or someone can accidentally touch the contacts). If the electrical flex or electrical components become damaged at any point, power to the fitting should be disconnected immediately and not operated until the damaged parts are fixed/replaced.

Cleaning and Maintenance

Metal finishes should only be cleaned with a soft, dry cloth. Do not use polishes or abrasives. Switch off power to the fitting before cleaning.

Established in 1990, Original BTC manufactures relaxed, familiar lighting for traditional and contemporary homes. All products are hand-assembled in Oxford from high quality components, produced in the UK.

ORIGINALBTC.COM
+44 (0)1993 882 251
UNIT 21 / 22 AVENUE ONE, STATION LANE, WITNEY, OX28 4XZ, ENGLAND



Brass Bulkhead Fitting

Instruction Manual

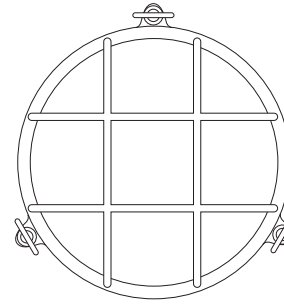

Brass Bulkhead Fitting
with Internal Fixing Point
7027

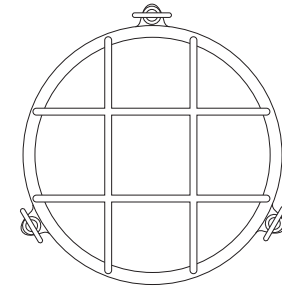

Brass Bulkhead Fitting
with Internal Fixing Point
7028

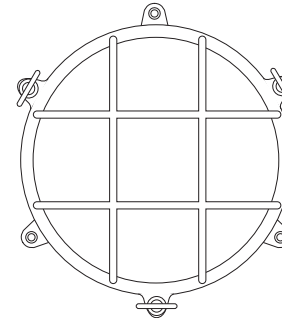

Brass Bulkhead Fitting
with External Fixing Point
7029

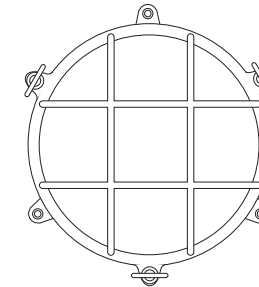

Brass Bulkhead Fitting
with External Fixing Point
7030

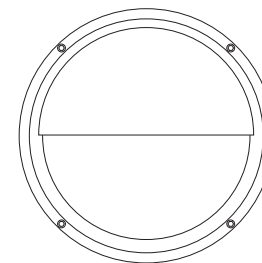

Brass Bulkhead Fitting
with Internal Fixing Point
7225

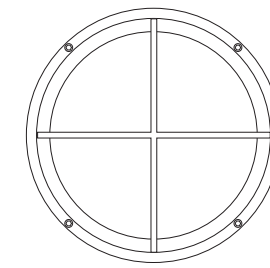

Brass Bulkhead Fitting
with Internal Fixing Point
7226

ORIGINAL BTC
BRITISH LIGHTING MANUFACTURERS
LONDON - PARIS



Brass Bulkhead Fitting

| 120V ac 60Hz | IP54

US-DP7027 Brass Bulkhead Fitting
 US-DP7028 Brass Bulkhead Fitting
 US-DP7029 Brass Bulkhead Fitting

US-DP7030 Brass Bulkhead Fitting
 US-DP7225 Brass Bulkhead Fitting
 US-DP7226 Brass Bulkhead Fitting

LAMP GUIDANCE					
PRODUCT	BASE	SHAPE	TYPE*	WATTAGE**	
US-DP7028 US-DP7030	E26	A BALL	INCANDESCENT ✓ CFL ✓ ECO-HALOGEN ✗ LED ✓	60W MAX 15W n/a 12W	
US-DP7027 US-DP7029	E26	A BALL	INCANDESCENT ✓ CFL ✓ ECO-HALOGEN ✗ LED ✓	75W MAX 18W n/a 15W	
US-DP7225 US-DP7226	E26	A BALL	INCANDESCENT ✓ CFL ✓ ECO-HALOGEN ✗ LED ✓	100W MAX 20W n/a 18W	

* Warm white (2700k) low energy lamps recommended.
 ** Wattage value provided as a guide to suitable lamps. Lower wattage than stated may be used.

Installation Diagram

E26 Lampholder Diagram

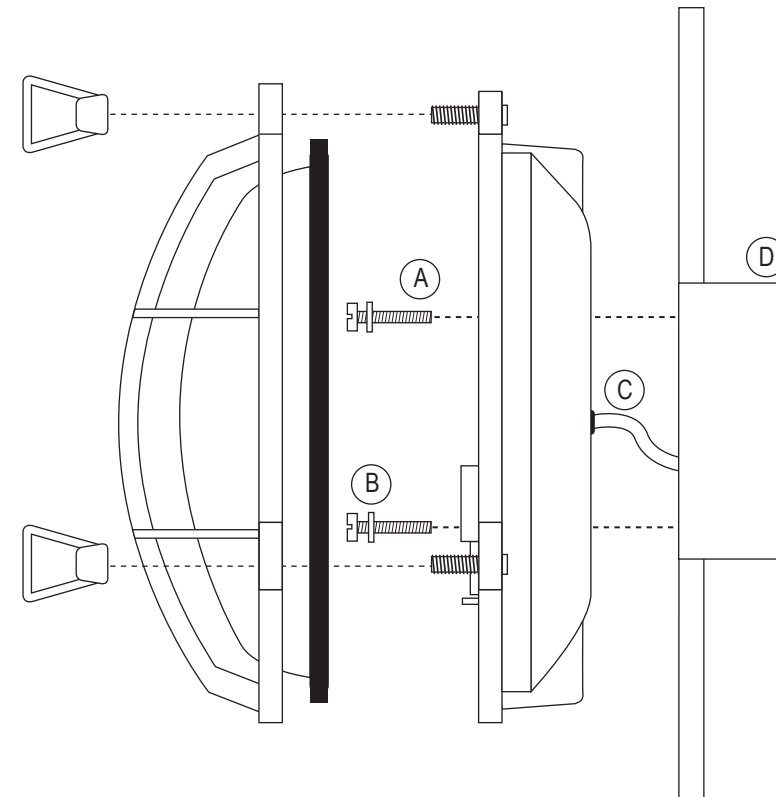
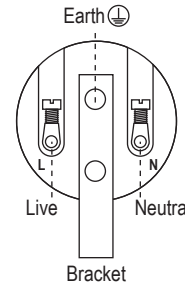

Fixings not supplied. The screws from your junction box may be compatible with the fitting or suitable screws and wall plugs may be required.

Key	
A	Screws*
B	Rubber Seals
C	Main Supply*
D	Junction Box*
*	Not Supplied

PLEASE READ THE INSTRUCTIONS ON THE REVERSE BEFORE YOU BEGIN INSTALLING YOUR LIGHT

Installation and Assembly Instructions

This fitting comes unwired. The lampholder will require wiring into main supply. Remove wing nuts to remove guard and glass, then follow the instructions overleaf to install light fitting.

When positioning fitting, ensure the bulbholder side is at the bottom of the appliance. Having completed installation, screw wing nuts through guard to base plate so the glass is held firmly in place, creating a tight seal. DO NOT OVERTIGHTEN.

