

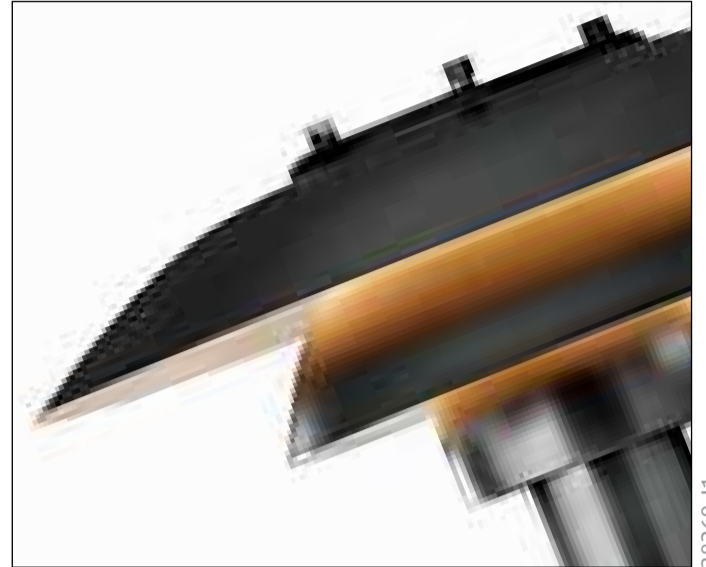

# PH 3-2½ Wall

Design Poul Henningsen

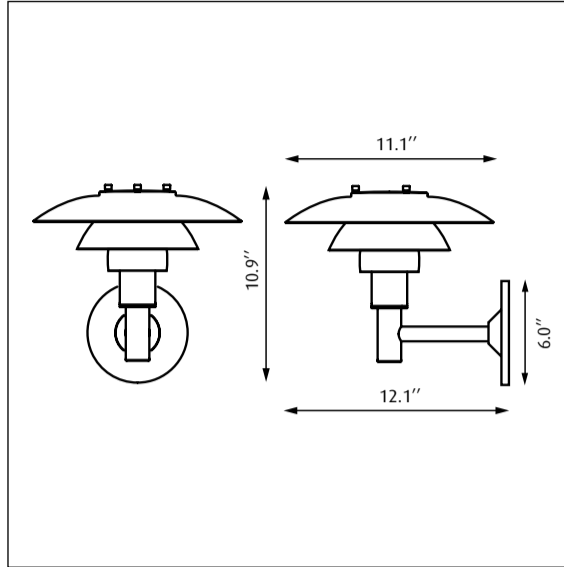

38269-11

Light source	Voltage	Weight	Electric shock protection	Ingress protection
<b>1/15W LED/A-19/ medium</b> 	<b>Max 120V</b>	<b>5,5 Lbs</b>	<b>Cl. I</b>	<b>IP 20, wet location</b>

**Recommended cleaning substances:**

Wipe off dust with a dry, soft cloth. Remove greasy spots etc. with a soft cloth dampened in lukewarm water (<122° F/ 50° C) with a mild detergent. Never use detergents containing abrasives and solvents.

Warning: Scouring powder and similar substances will scratch surfaces.

All installation is subject to local code and jurisdiction. Consult a qualified electrician to ensure correct branch circuit conductor. The installer must ensure that the wall can support the luminaire's weight. The installer must if necessary reinforce the wall structure by adequate means.



Louis Poulsen A/S disclaims any liability if a half mirror light bulb is used. This type of light source reflects the heat and may damage/melt parts of the fixture.

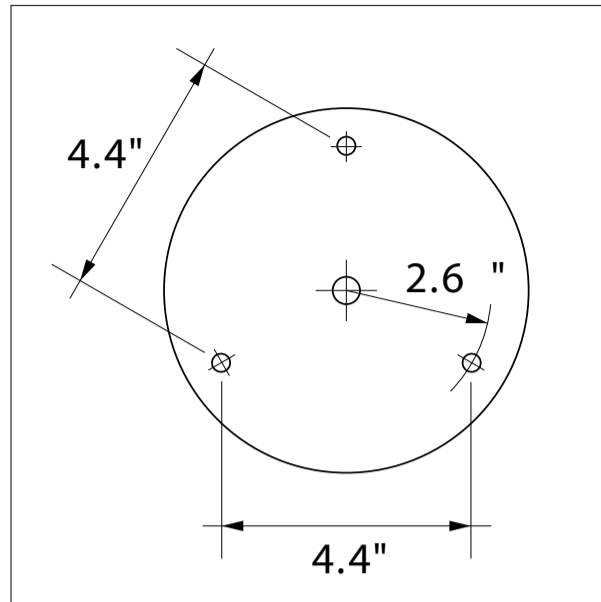
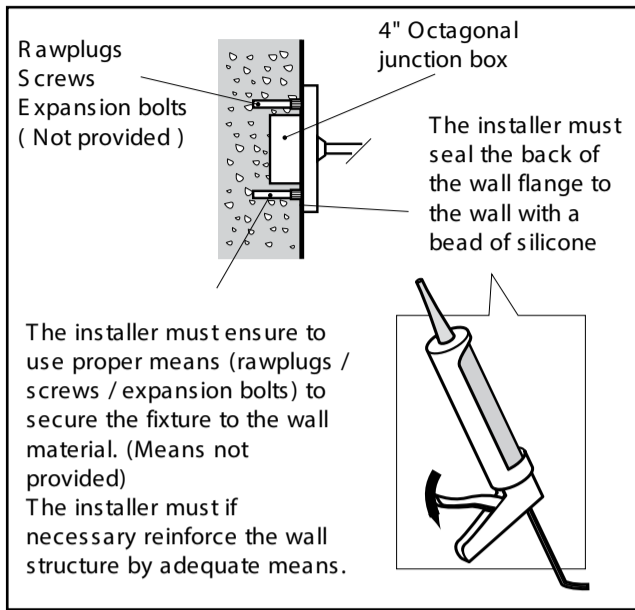



CONNECT WIRES TO JUNCTION BOX IN WALL

- Green to Green (ground)
- White to White
- Black to Black

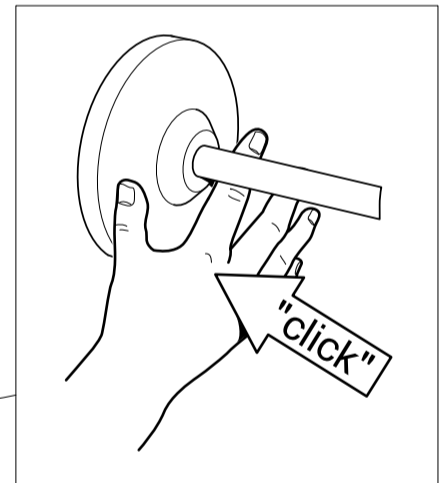
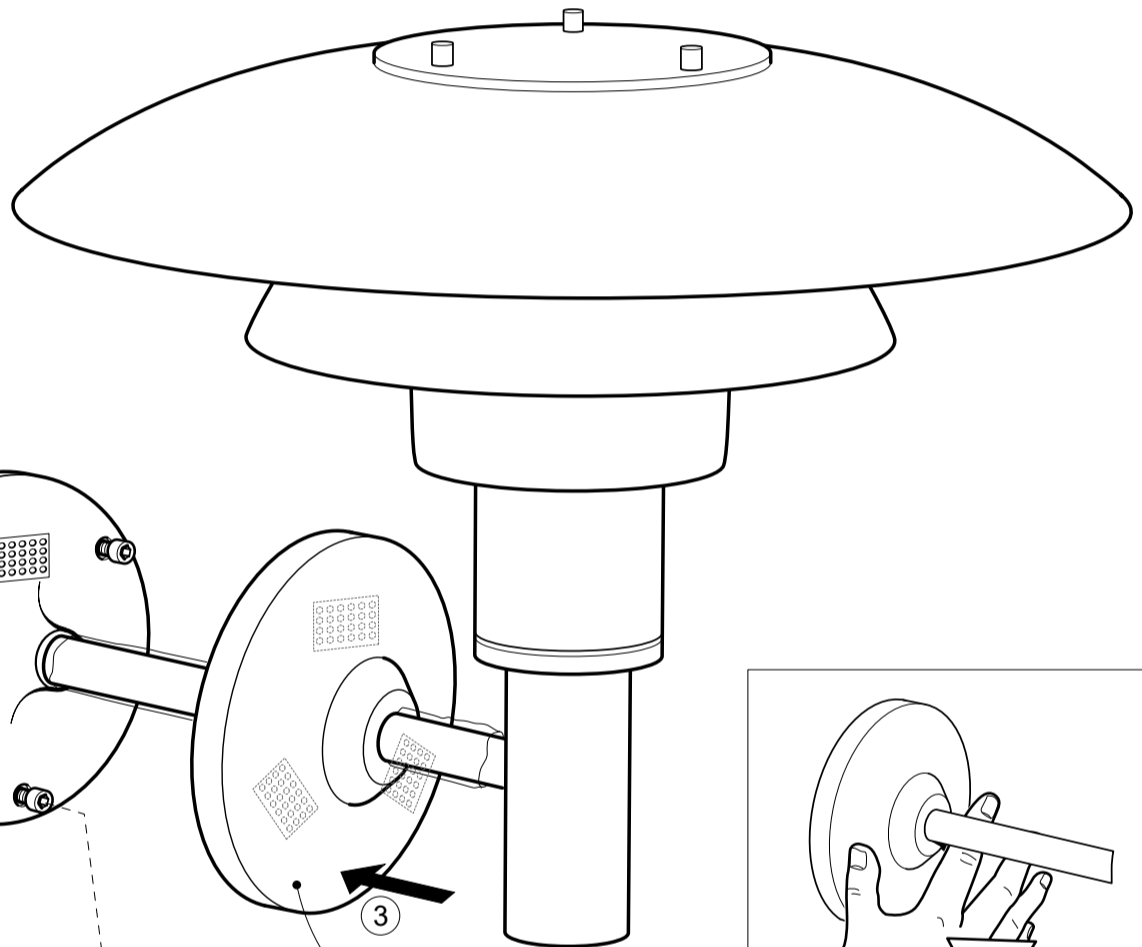
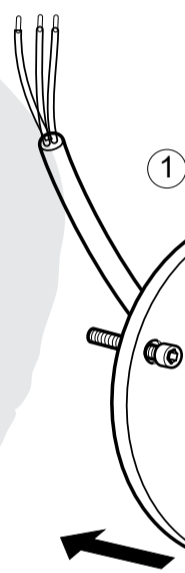
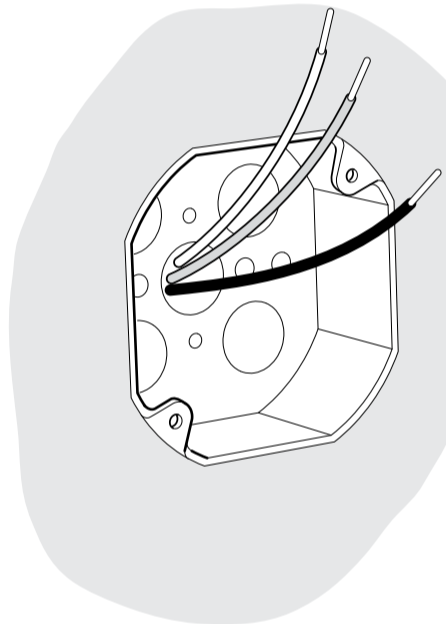

x 3



 Use only light source in accordance to the lamp Replacement label on the luminaire

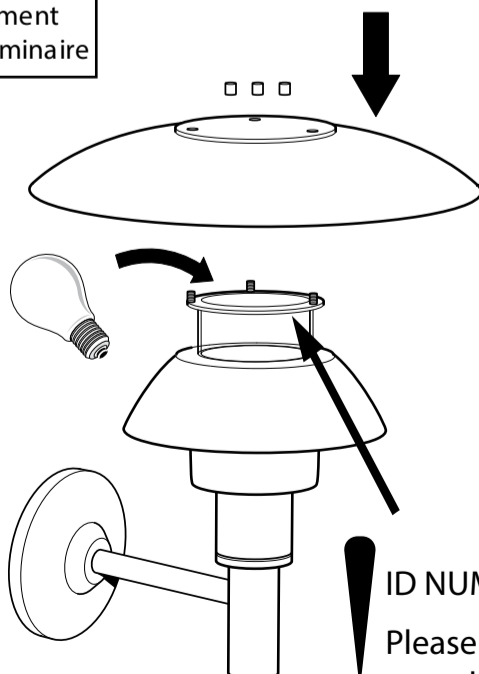
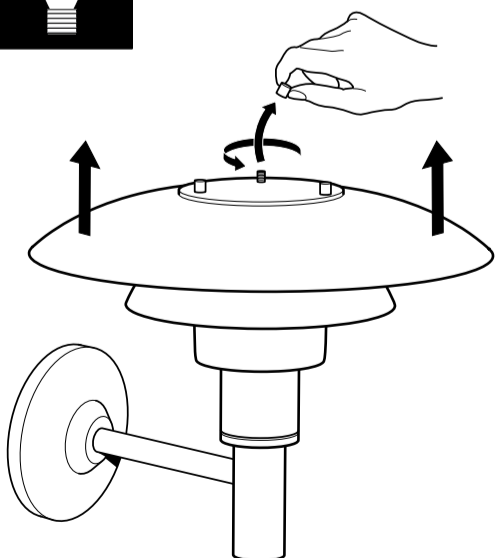
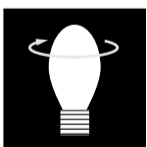

! ID NUMBER: \_\_\_\_\_  
Please register ID number at [www.louispoulsen.com](http://www.louispoulsen.com)

