

## INSTALLATION INSTRUCTIONS

### WARNING

- Before starting the wiring, joint the earth wire to the fixing bracket.
- Always unplug the appliance from the power socket before beginning installation or any sort of maintenance work.
- Use a qualified electrician for installation of this lighting fixture.
- Installation of this fixture must comply with local building codes.
- A fixture weighing more than 50lb must be mounted or supported independently of an outlet box.
- If the power lead to the appliance is damaged in any way, it must only be replaced by the manufacturer, an authorised service centre or a qualified electrician to prevent any sort of risk for the user.

### INSTRUCTIONS

- Avant d'effectuer le câblage, relier le conducteur de terre à l'élément de fixation.
- Avant de procéder à l'installation de l'appareil, ainsi qu'avant toute opération d'entretien, il est nécessaire de couper le courant au disjoncteur.
- Employer un électricien qualifié pour l'installation de ce luminaire.
- L'installation de ce montage doit être conforme à codes du bâtiment locaux.
- Un montage pesant plus que 50lb doit être monté ou soutenu indépendamment d'une boîte de sortie.
- Afin d'éviter tout risque, si le câble électrique de cet appareil est endommagé il doit être remplacé exclusivement par le fabricant, son service après-vente ou par du personnel qualifié équivalent.

### ADVERTENCIAS

- Antes de realizar el cableo, acople el conductor de puesta a tierra a la brida de sujeción.
- Antes de proceder a la instalación del aparato y en cualquier caso antes de efectuar cualquier operación de mantenimiento, corte la tensión de red.
- Usar un electricista calificado para la instalación de esta luminaria.
- La instalación de este accesorio debe conformarse con códigos técnicos de la edificación locales.
- Un accesorio que pesa más que 50lb se debe montar o apoyar independientemente de una caja de enchufe.
- Si el cable eléctrico de este aparato viene dañado, a fin de evitar peligros, debe ser sustituido exclusivamente por el constructor, por su servicio de asistencia, o de personal calificado equivalente.

## TECHNICAL DATA

### JJ GREAT - JJ BIG PENDANT

45W LED 220-240V 50/60Hz  
6691 lm CRI≥90  
148 lm/W  
Push Dim 0/1-10V DALI

### JJ GREAT - JJ BIG PENDANT

for US market only  
37W LED 120V 50/60Hz  
5623 lm CRI ≥ 90  
151 lm/W  
Push Dim 0/1-10V

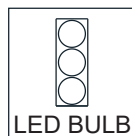

### LOCATION

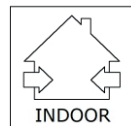

# LEUCOS®

## JJ GREAT PENDANT JJ BIG PENDANT

PENDANT LED

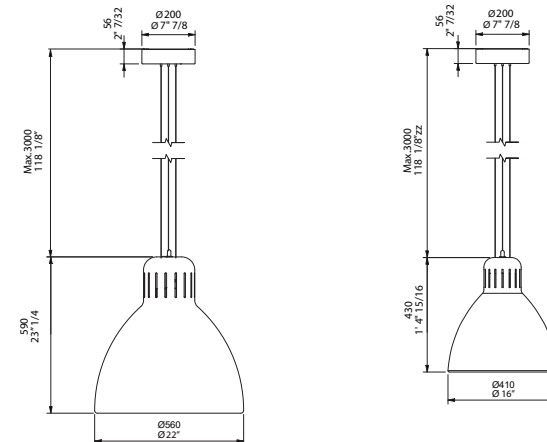

LEUCOS® A brand of Clann srl

www.leucos.com

via delle lavoro 22 - 30030 Salzano (VE) - Italy



Two installers  
Deux installateurs  
Dos instaladores

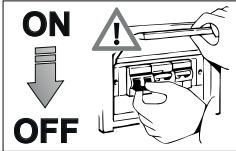

- ESEGUIRE LE OPERAZIONI DI MONTAGGIO SEGUENDO L'ORDINE NUMERICO PROGRESSIVO.
- FOLLOW THE ASSEMBLY INSTRUCTIONS BY READING THE NUMERICAL PROGRESSION.
- EXÉCUTER LES OPERATIONS DE MONTAGE, EN SUIVANT L'ORDRE DE NUMÉRATION PROGRESSIF.
- BITTE FOLGEN SIE DEN EINZELNEN SCHRITTEN DER MONTAGEANLEITUNG ENTSPRECHEND DER AUFSTIEGENDEN NUMMERIERUNG.
- EJECUTAR LAS OPERACIONES DEMONTAJE SIGUIENDO EL ORDEN NUMERICO PROGRESIVO.

1

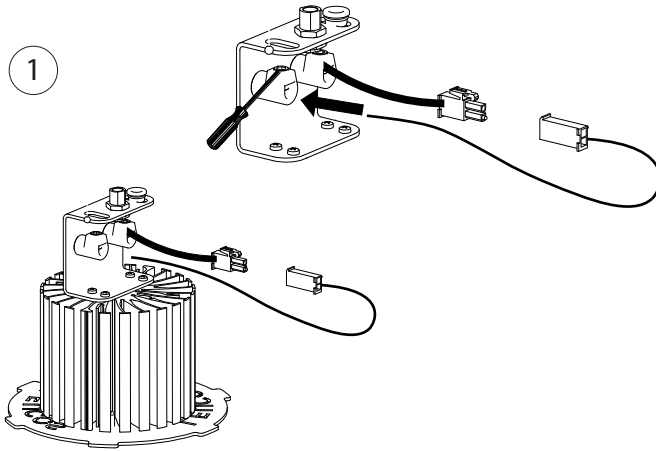

2

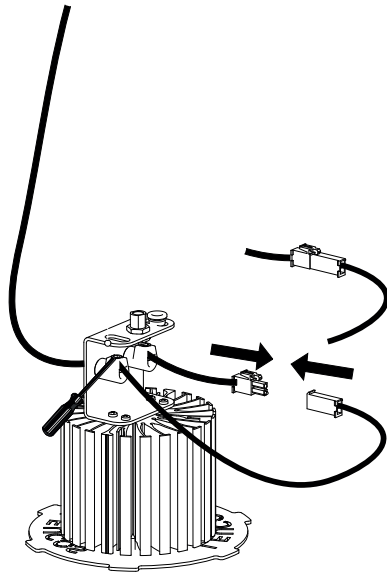

3

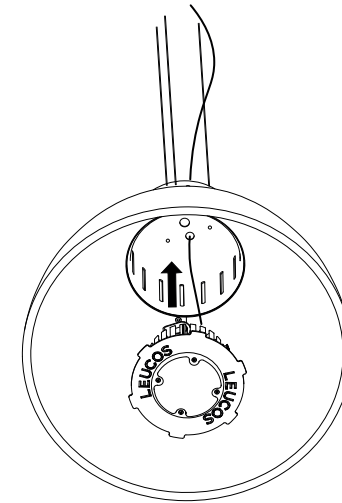

4

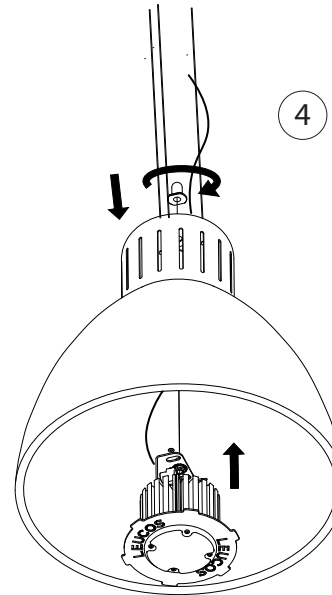

5

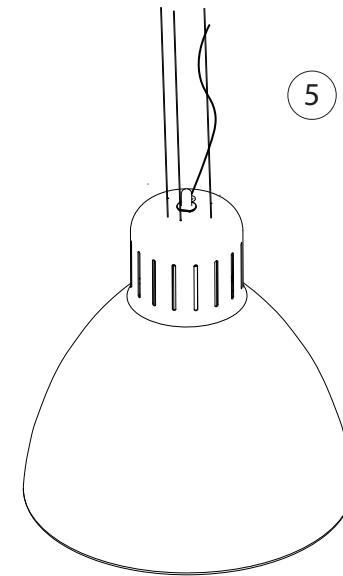

FOLLOW THE ASSEMBLY INSTRUCTIONS BY READING THE NUMERICAL PROGRESSION.  
EXÉCUTER LES OPERATIONS DE MONTAGE, EN SUIVANT L' ORDRE DE NUMERATION PROGRESSIF.  
EJECUTAR LAS OPERACIONES DEMONTAJE SIGUIENDO EL ORDEN NUMERICO PROGRESIVO.

Label  
1 - 10V  
+ -

Label  
SEC  
+ -

Label  
N  
⊖ ⊕  
Push L

Label  
1 - 10V  
+ -  
Push L

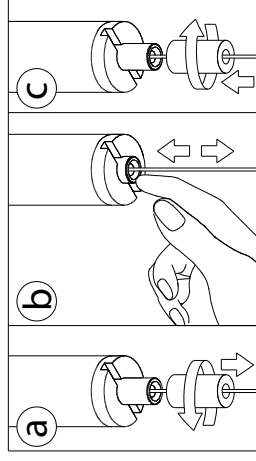
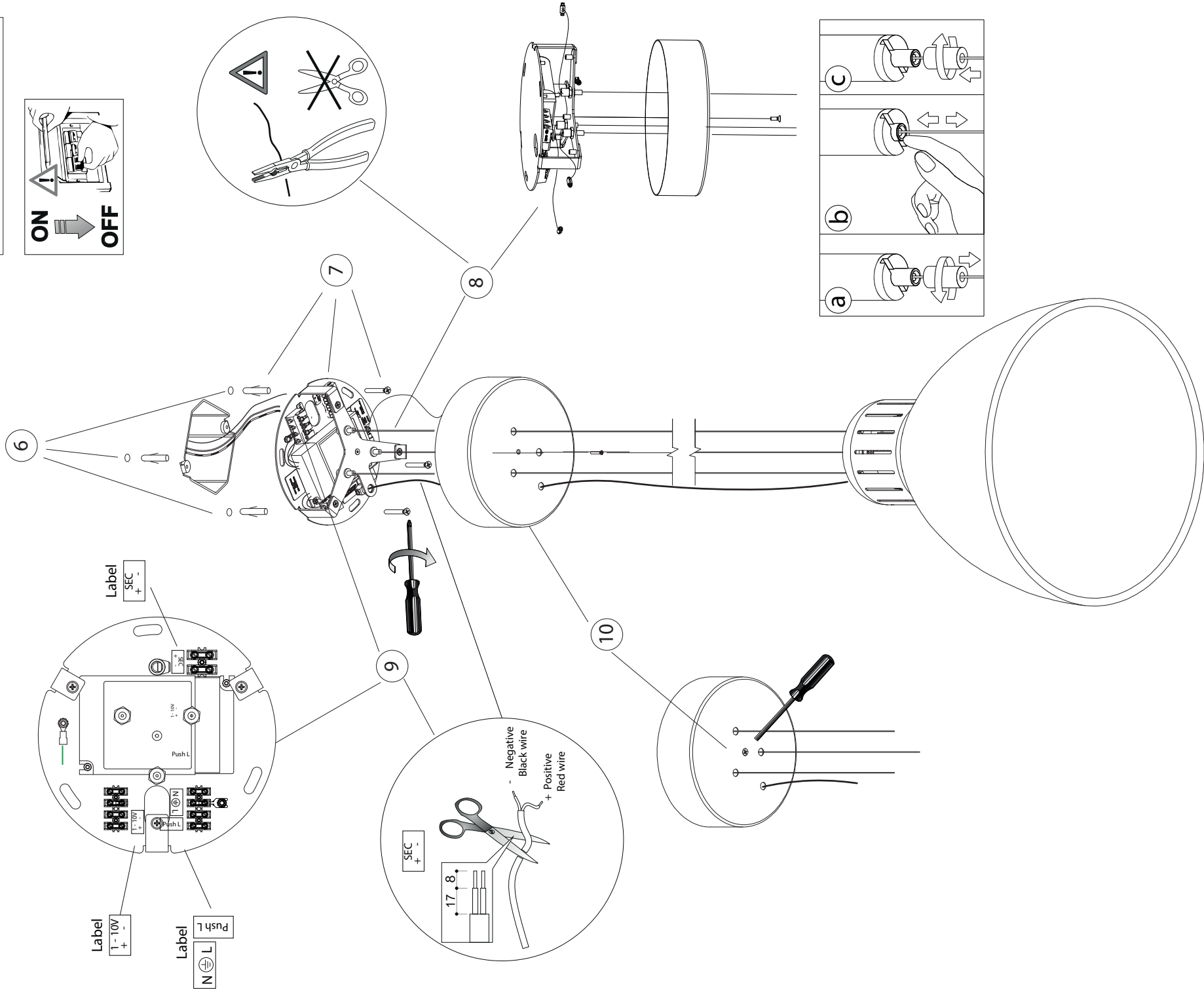
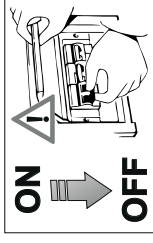

The safety and reliability are guaranteed only when installation instructions are properly followed. Please retain this instruction sheet for future reference.  
La sécurité de cet appareil n'est pas garantie en cas de non-respect de ces instructions, qu'il est nécessaire de conserver.  
La seguridad del aparato se garantiza sólo utilizando de forma apropiada las siguientes instrucciones, por lo tanto es necesario conservarlas.

# ISTRUZIONI PER LA SOSTITUZIONE DEL LED

## INSTRUCTIONS FOR LED REPLACEMENT

ESEGUIRE LE OPERAZIONI DI MONTAGGIO SEGUENDO L'ORDINE NUMERICO PROGRESSIVO.  
FOLLOW THE ASSEMBLY INSTRUCTIONS BY READING THE NUMERICAL PROGRESSION  
EXÉCUTER LES OPERATIONS DE MONTAGE, EN SUIVANT L'ORDRE DE NUMÉRATION PROGRESSIF.  
BITTE FOLGEN SIE DEN EINZELENEN SCHRITTEN DER MONTAGEANLEITUNG ENTSPRECHEND DER AUFSTEIGENDEN NUMMERIERUNG.  
EJACUTAR LAS OPERACIONES DEMONTAJE SIGUIENDO EL ORDEN NUMERICO PROGRESSIVO



Two installers  
Deux installateurs  
Dos instaladores

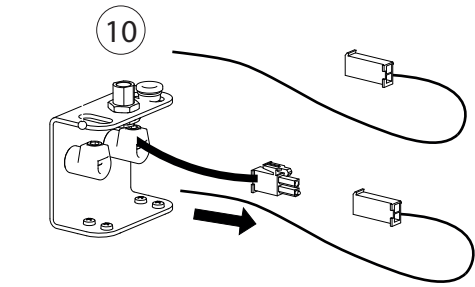
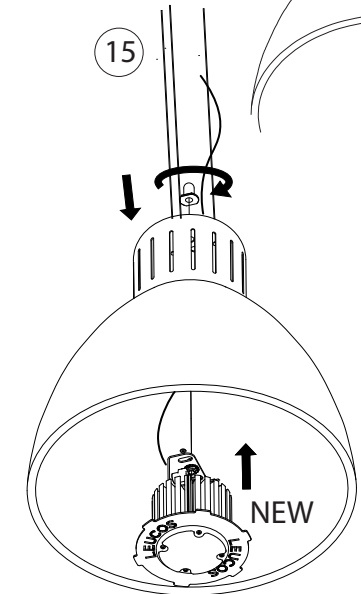
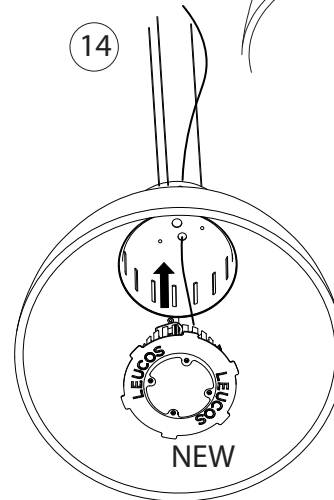
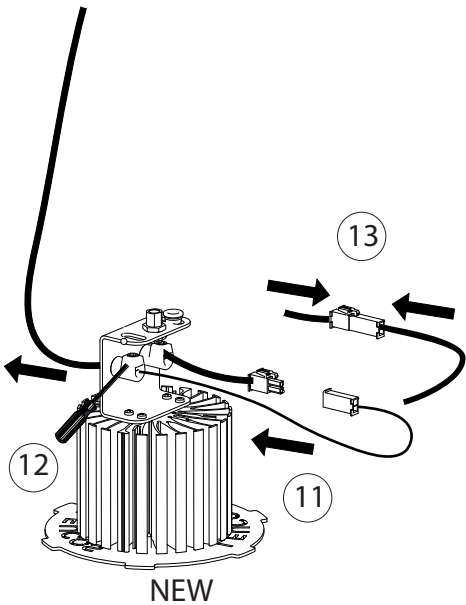
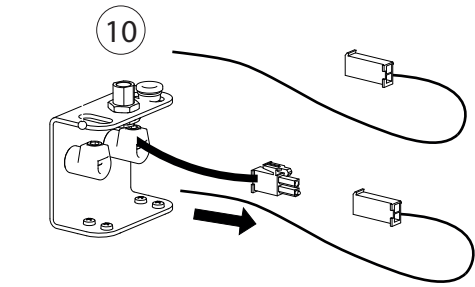
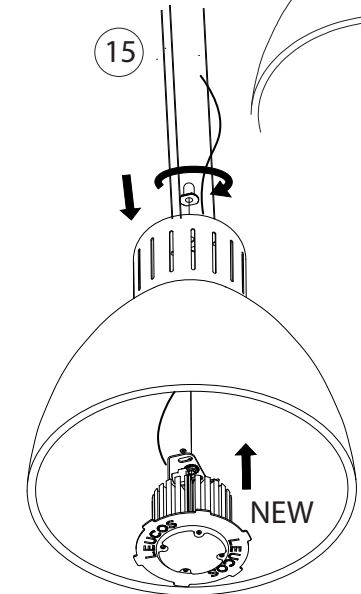
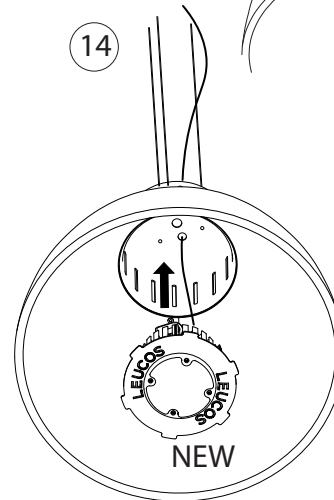
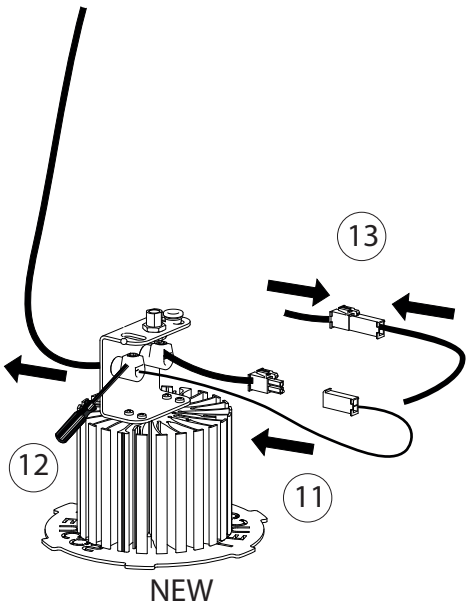
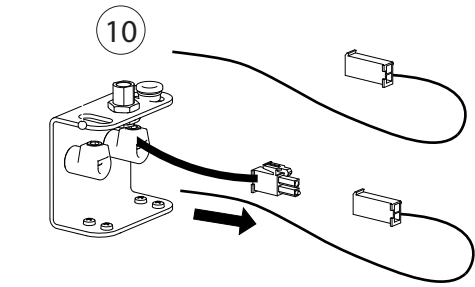
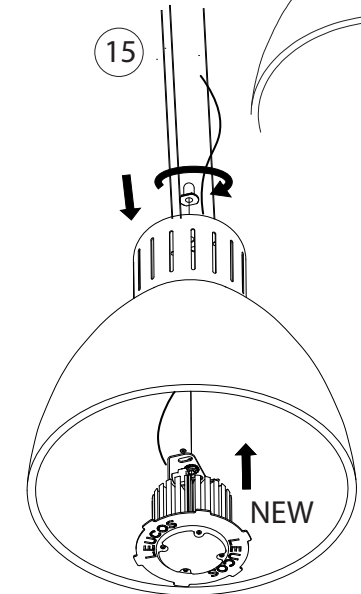
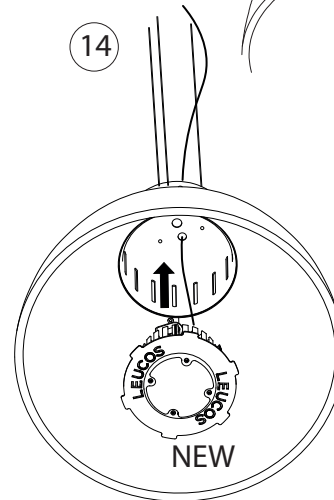
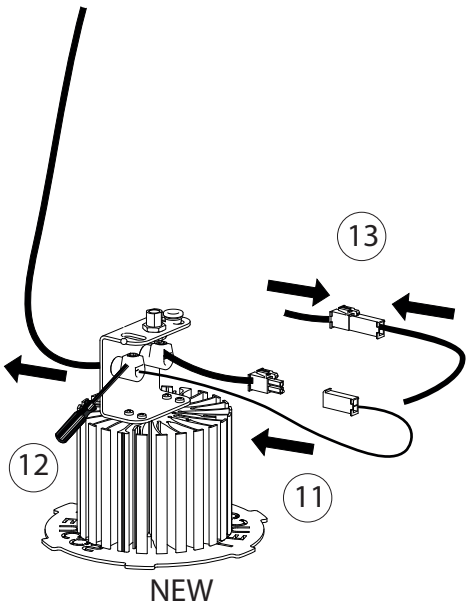
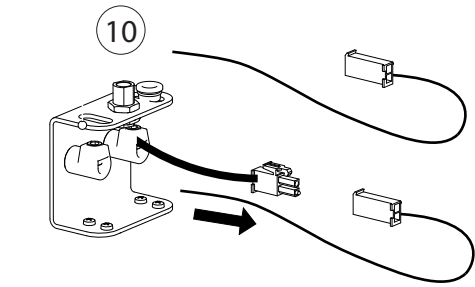
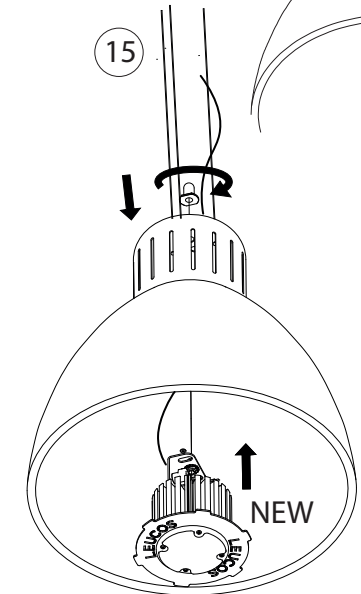
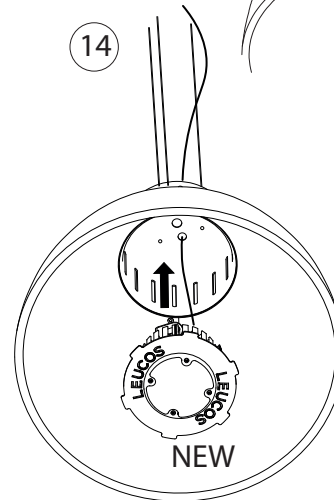
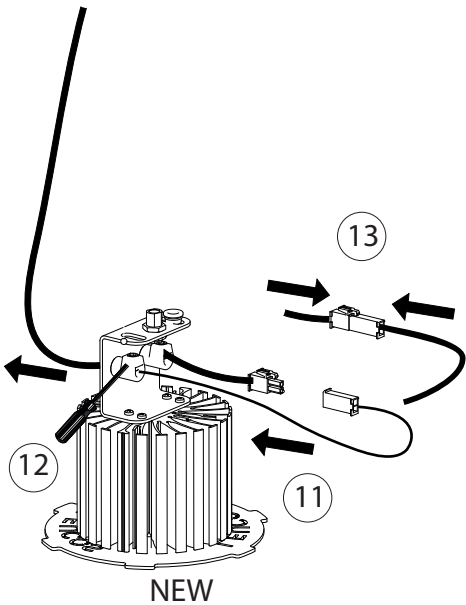
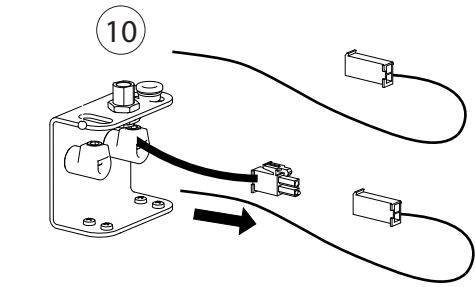
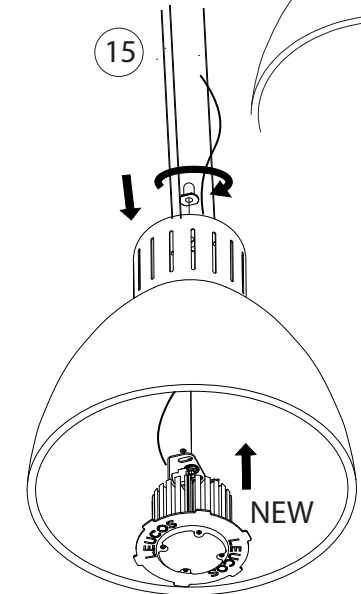
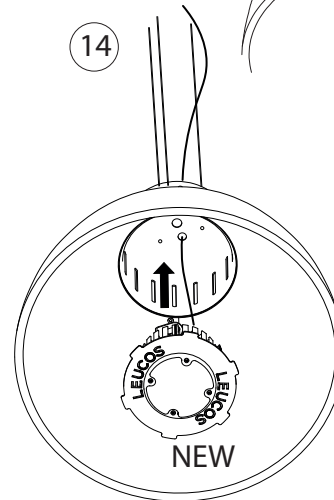
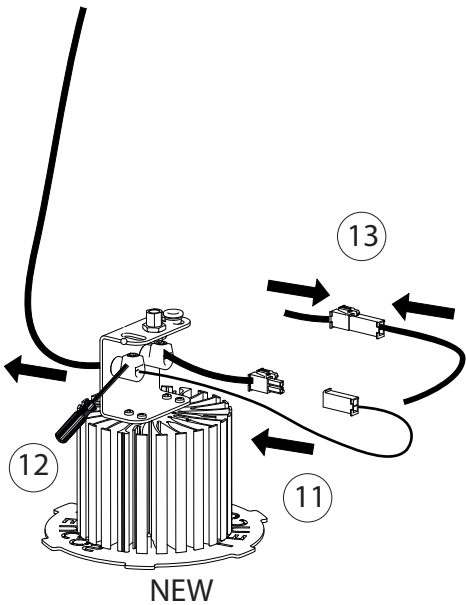
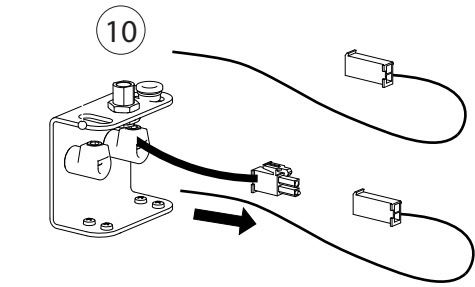
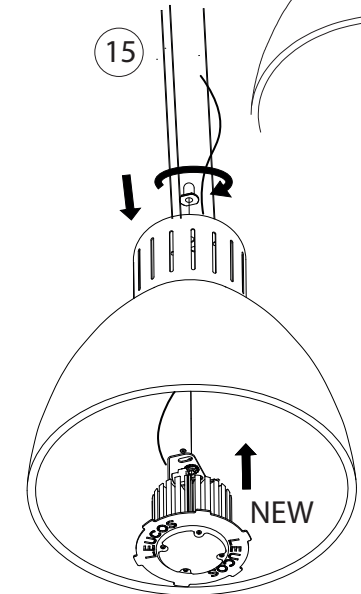
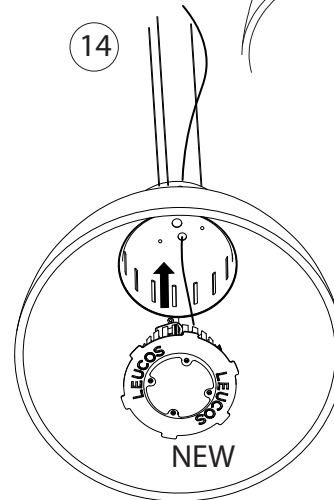
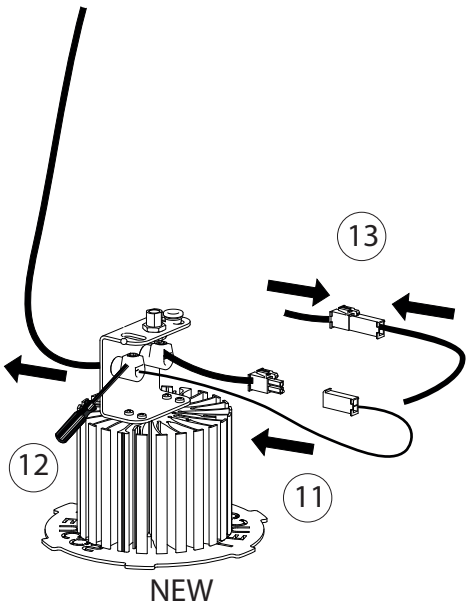
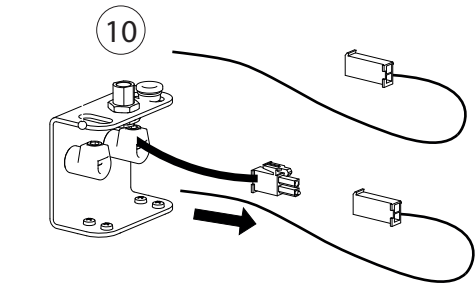
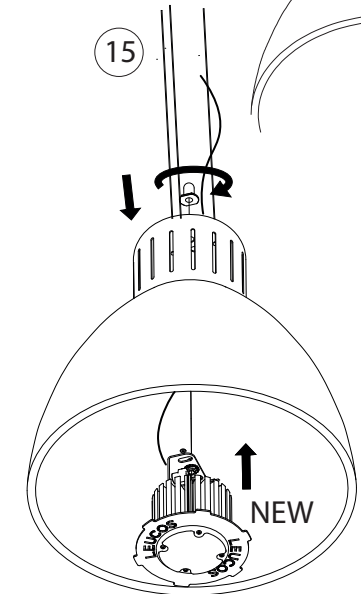
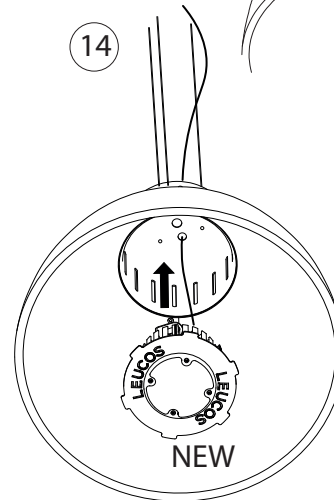
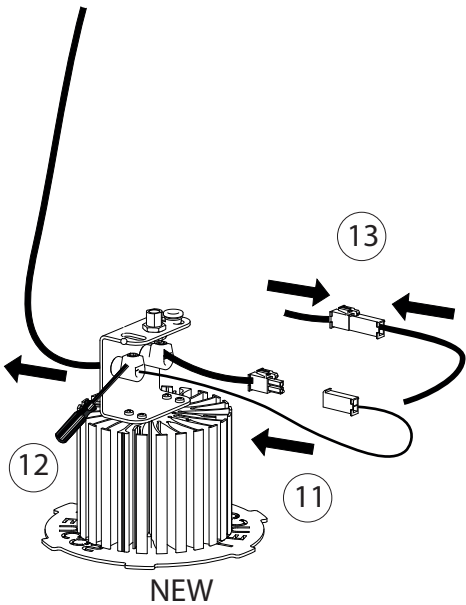
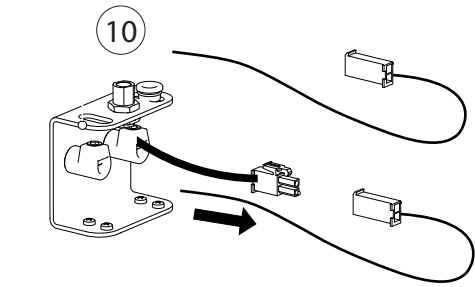
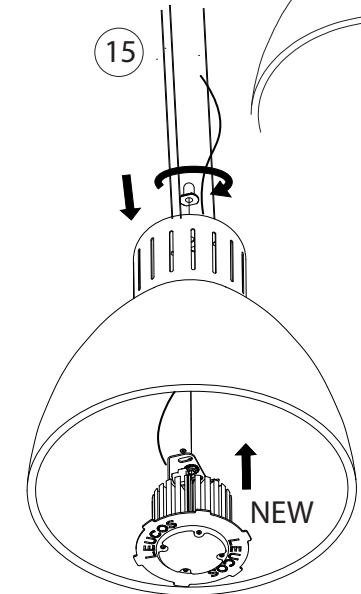
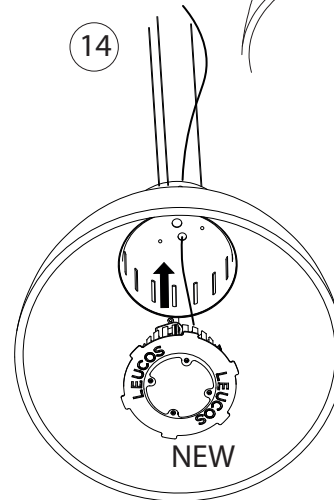
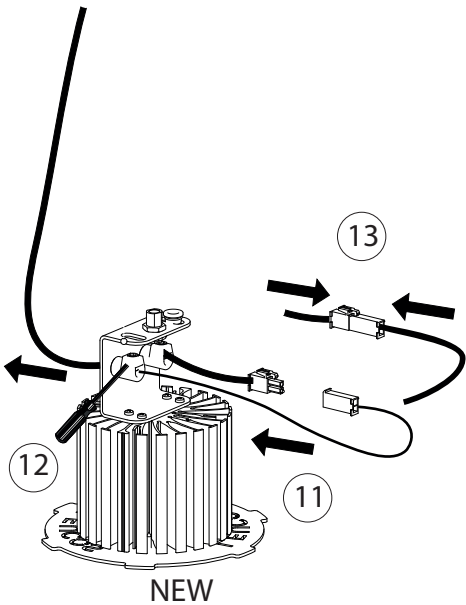
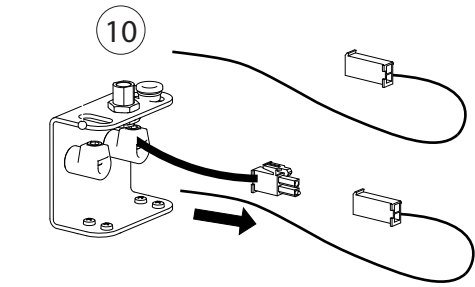
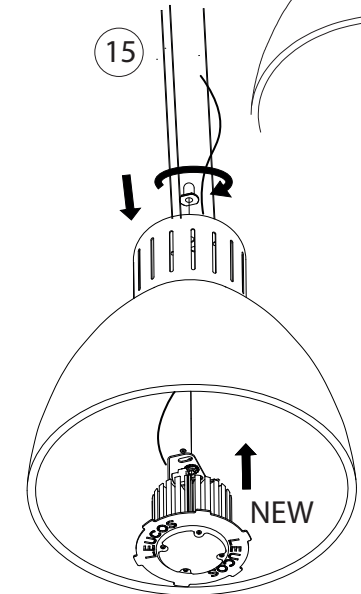
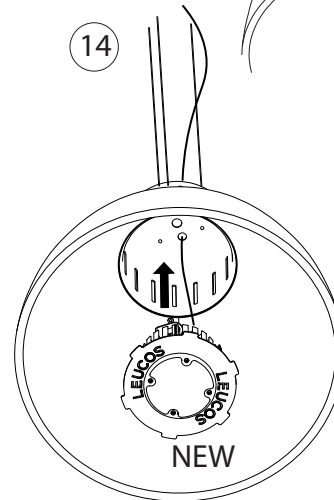
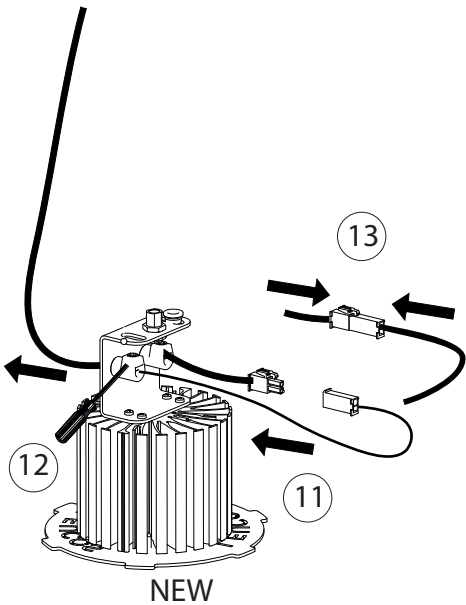
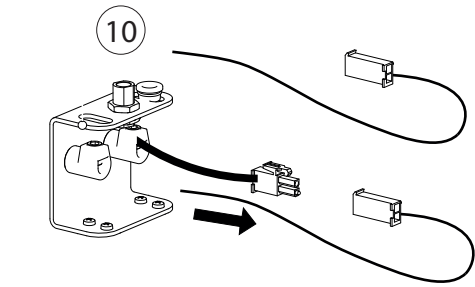
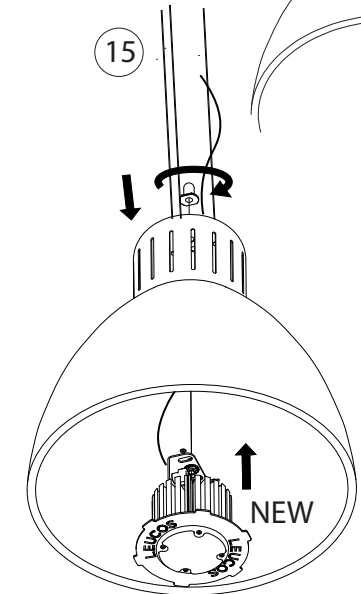
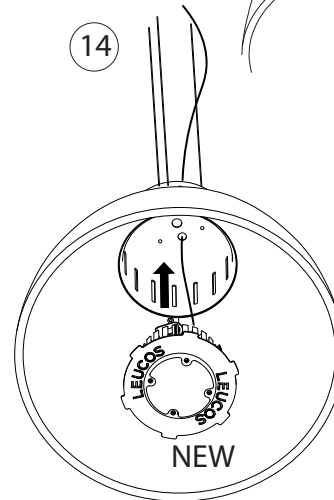
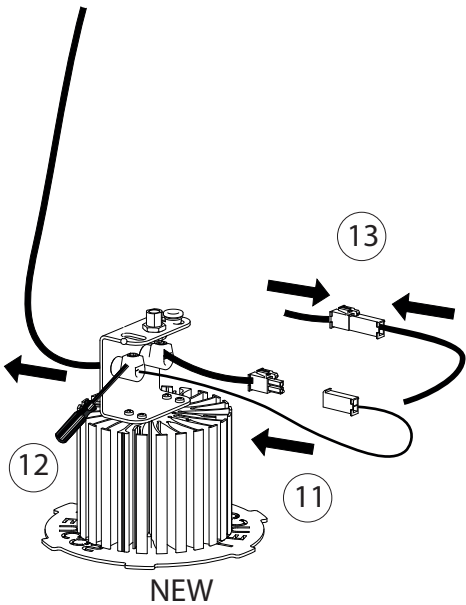
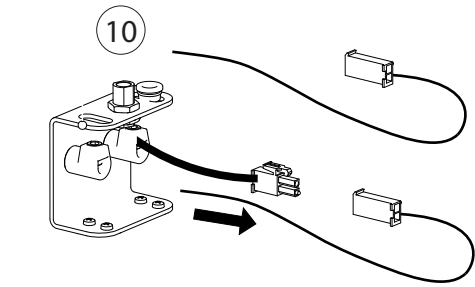
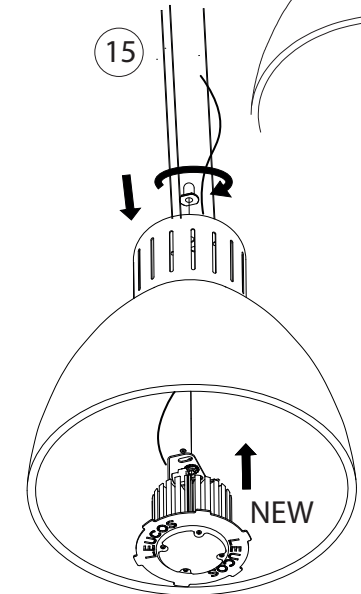
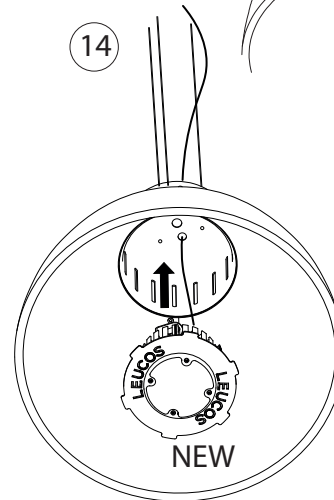
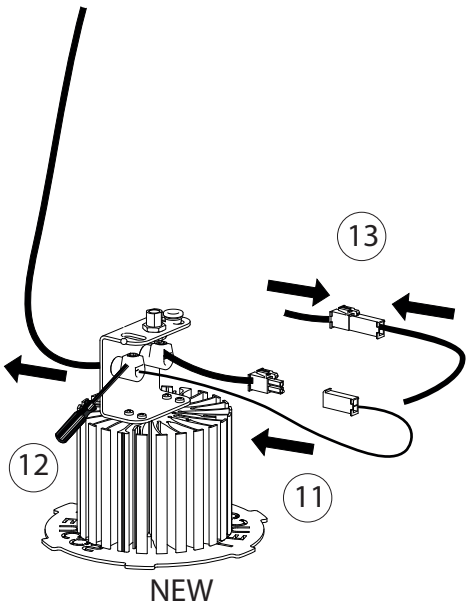
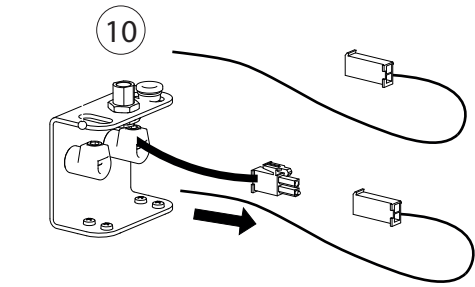
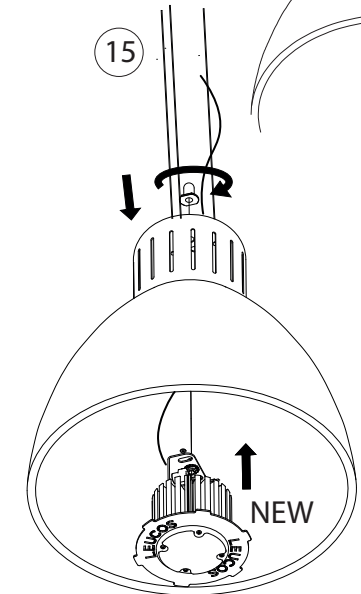
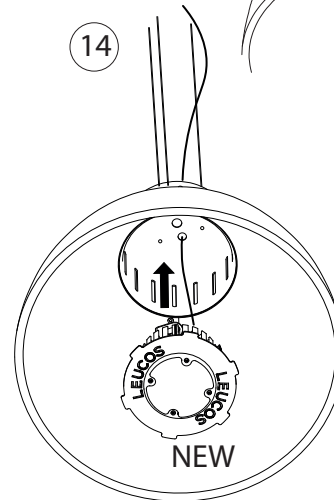
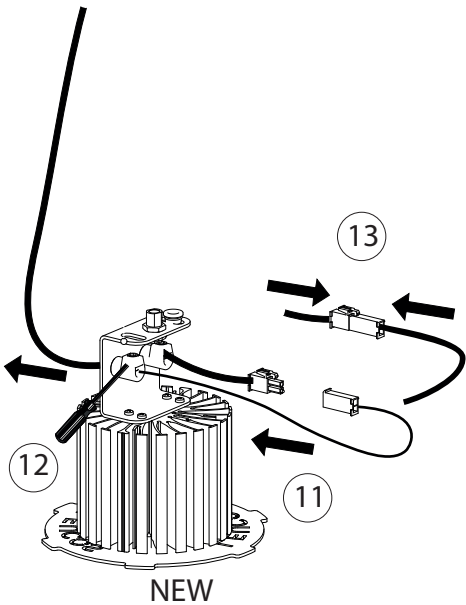
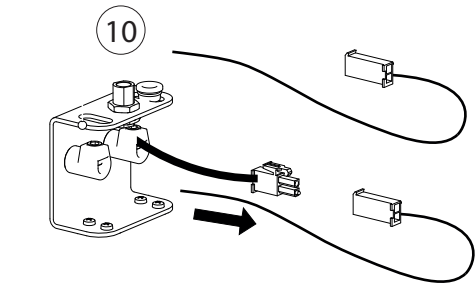
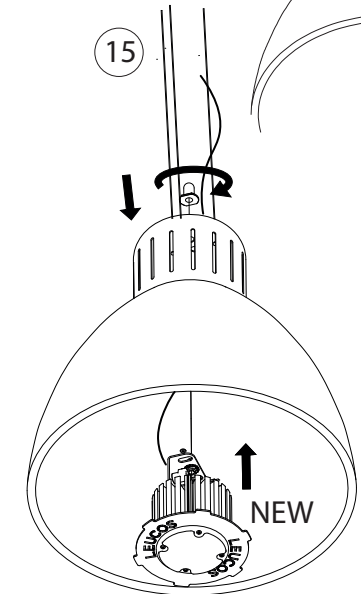
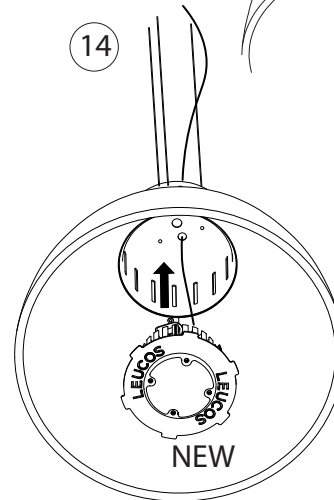
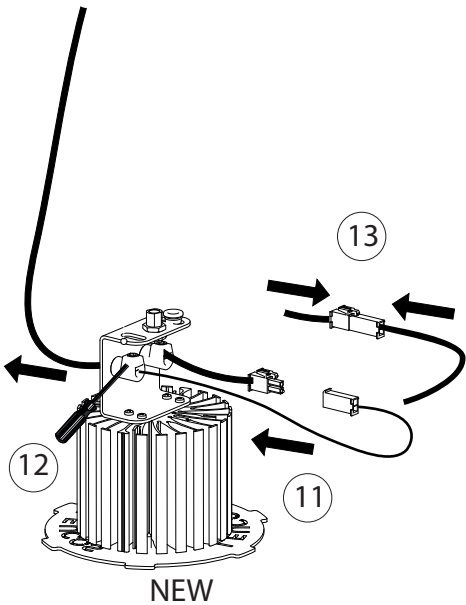
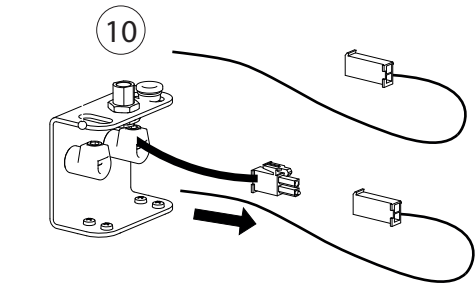
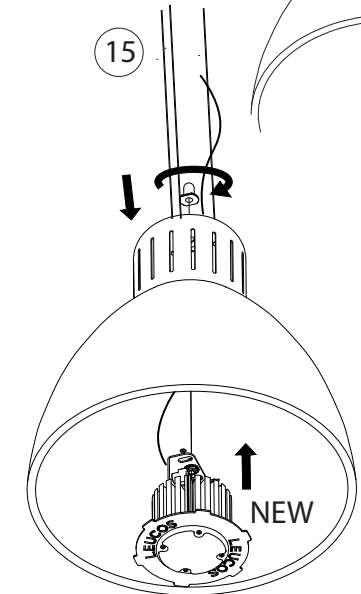
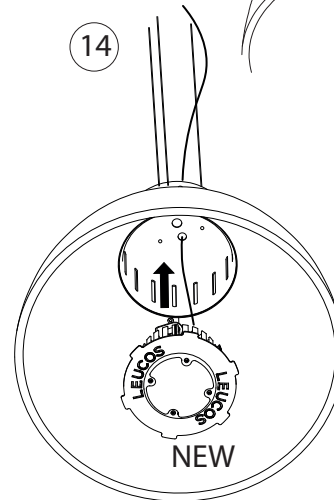
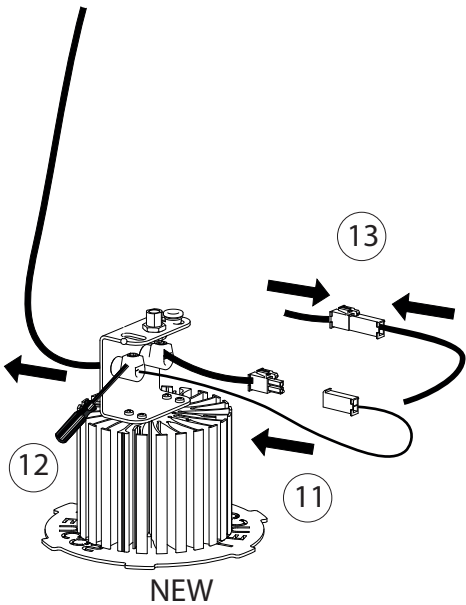
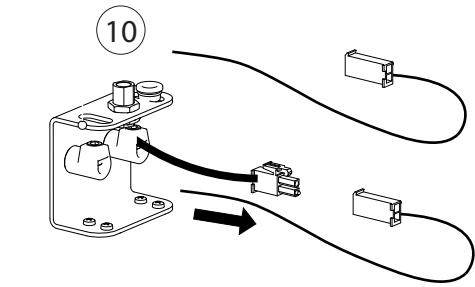
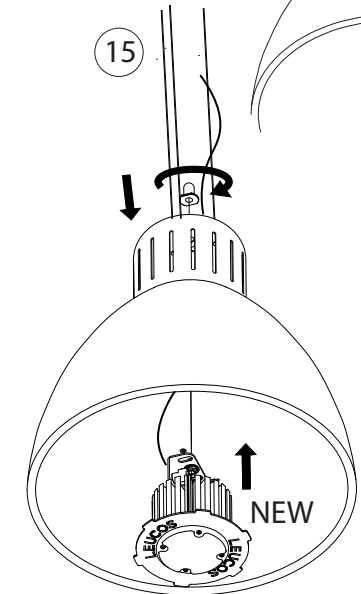
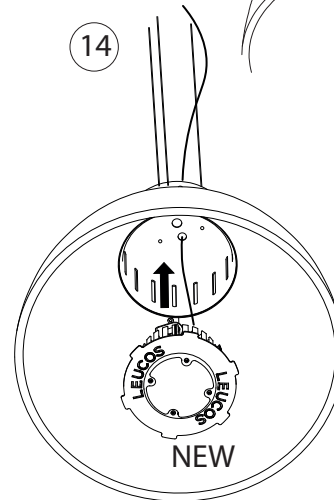
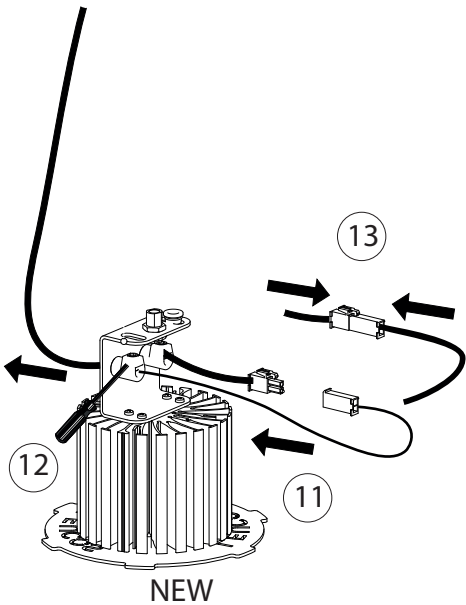
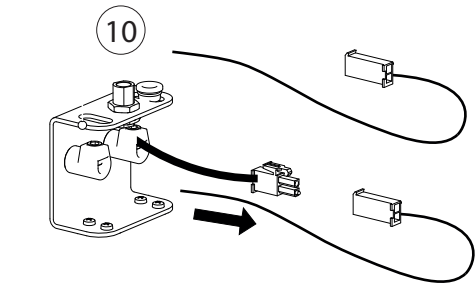
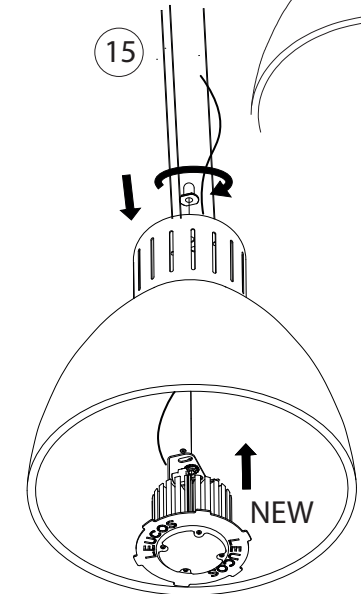
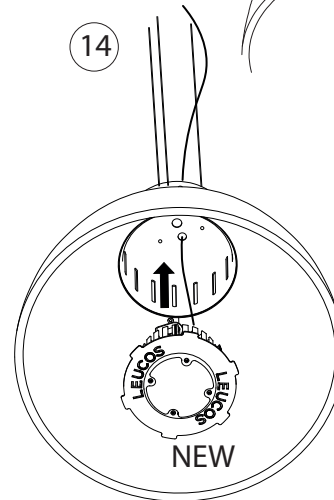
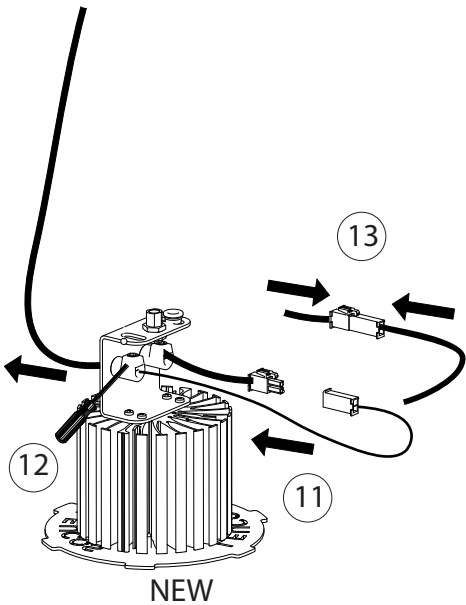
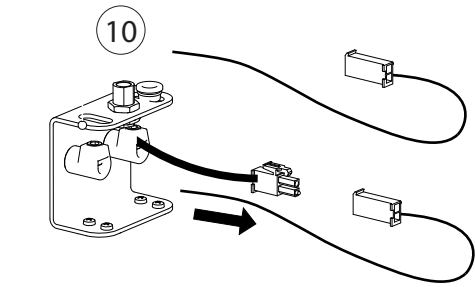
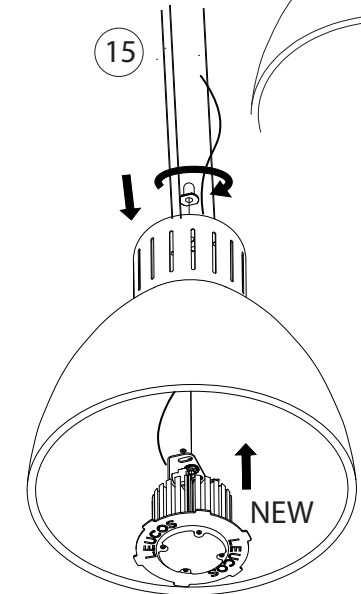
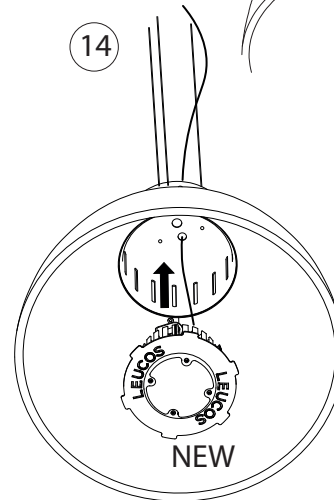
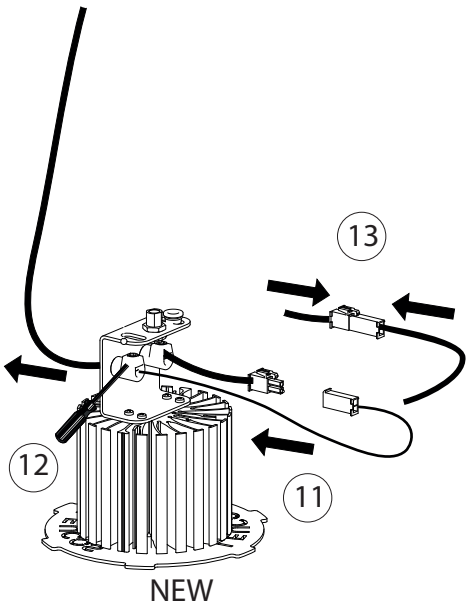
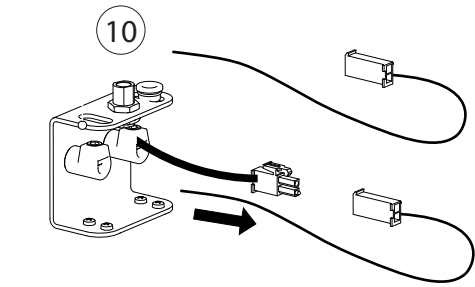
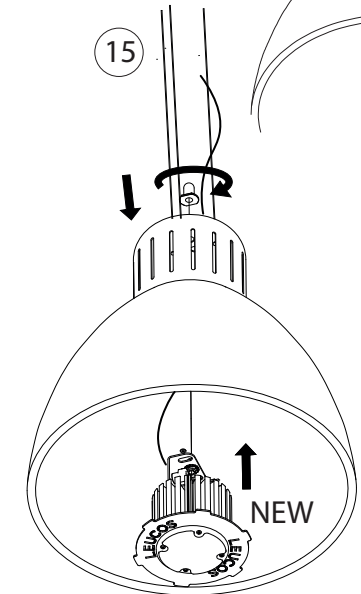
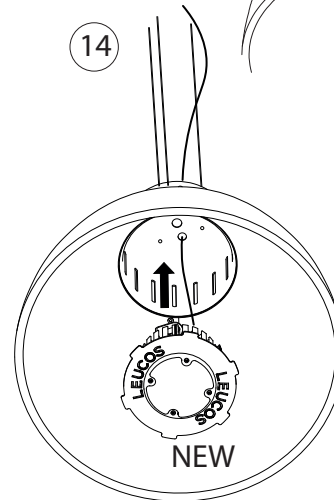
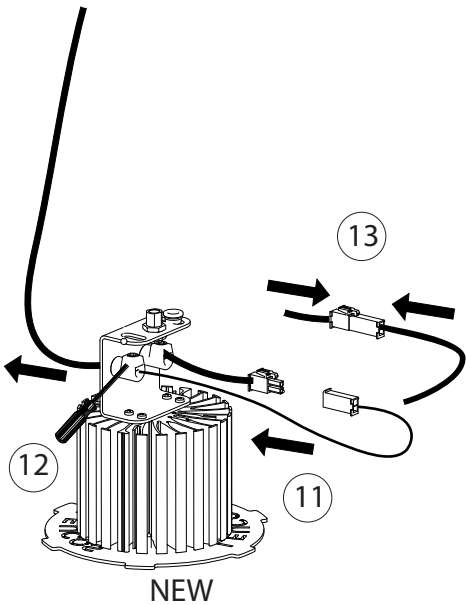
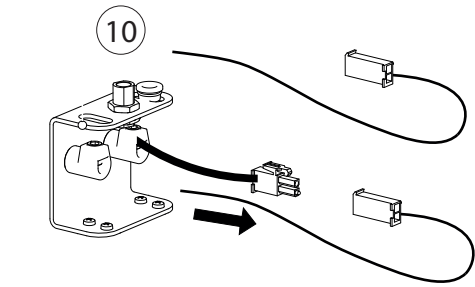
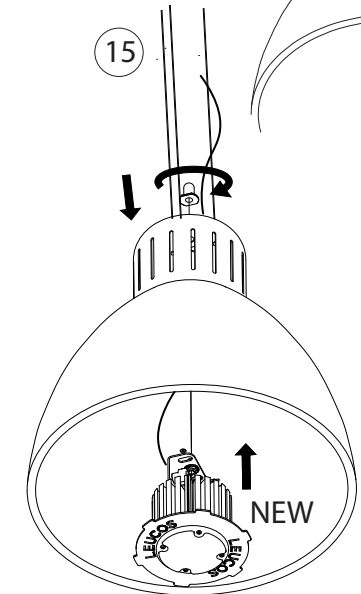
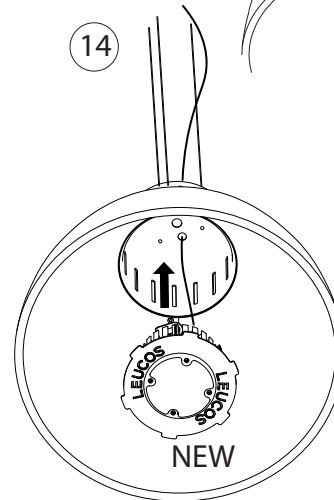
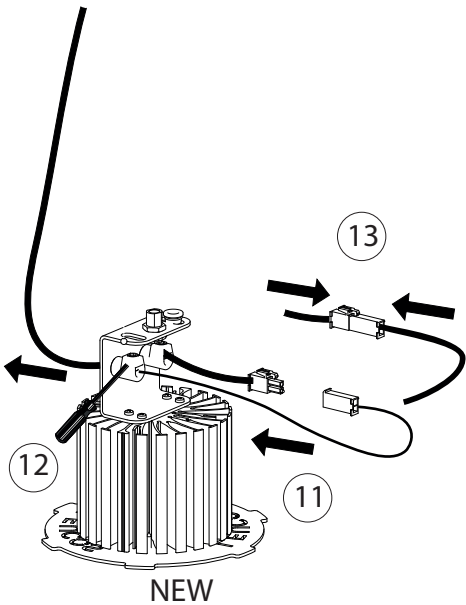
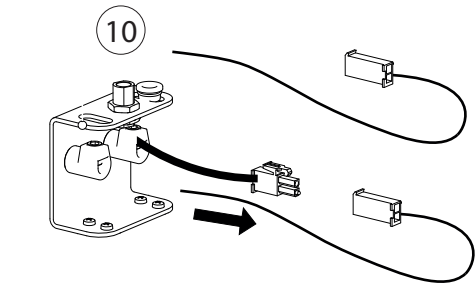
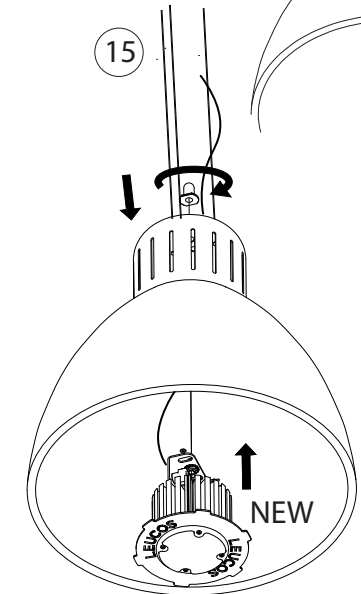
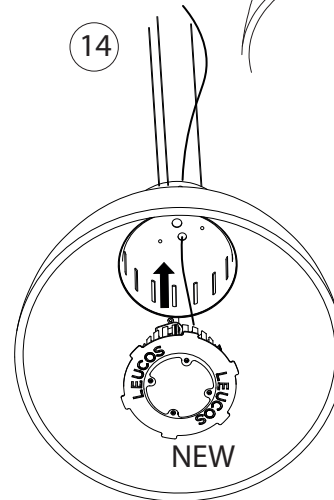
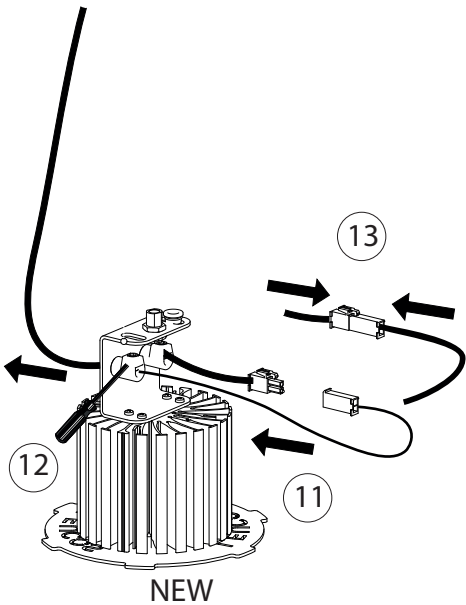
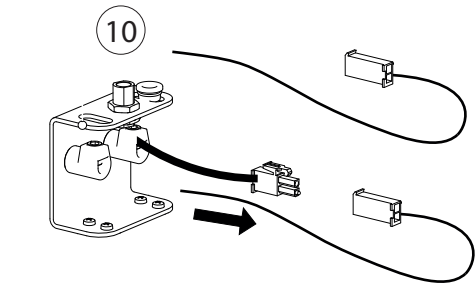
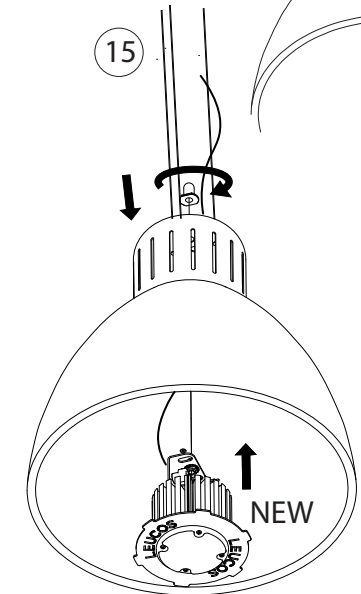
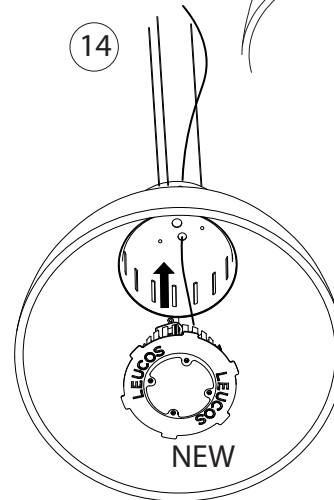
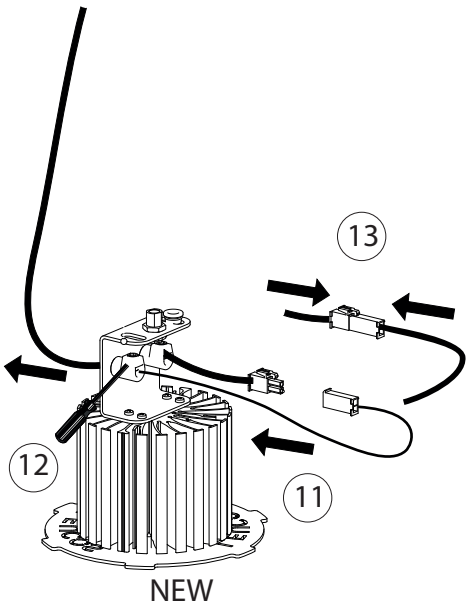
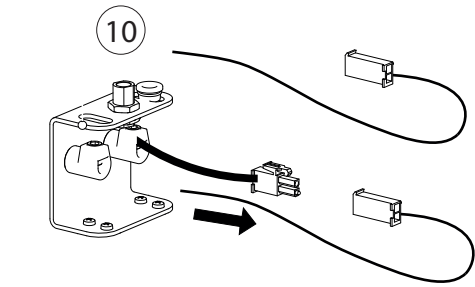
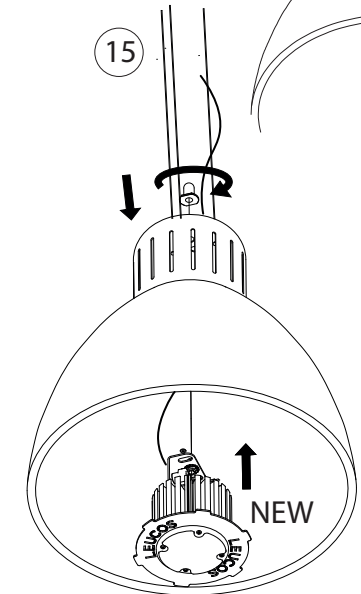
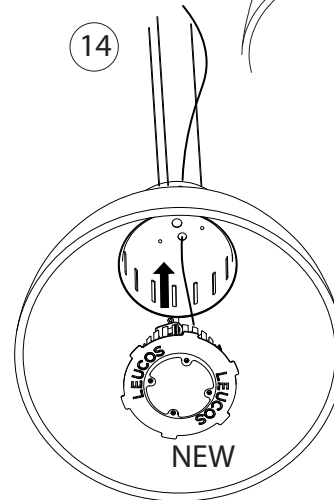
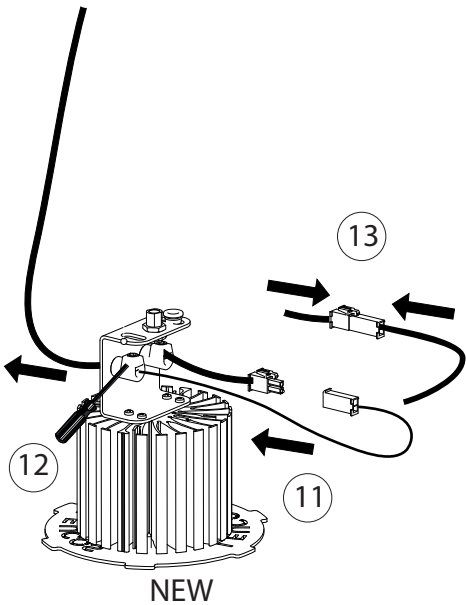
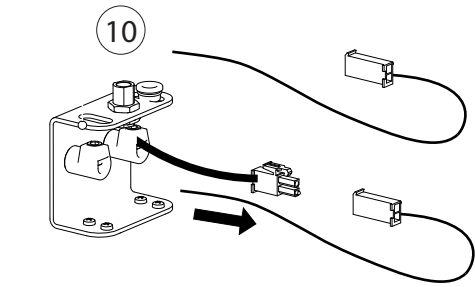
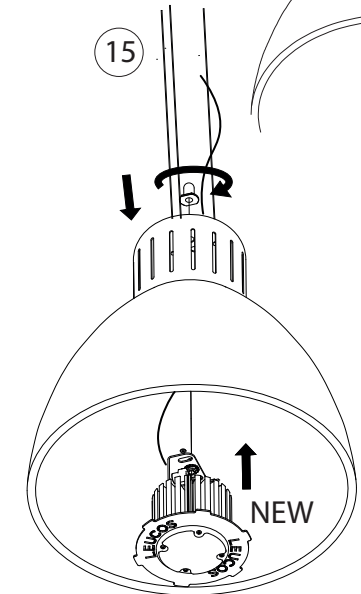
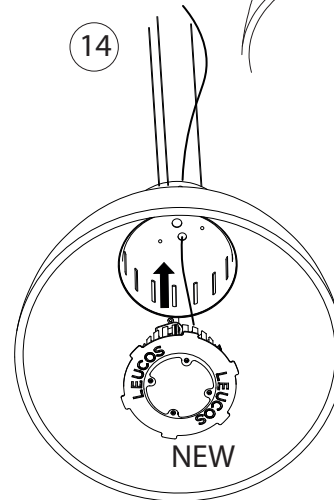
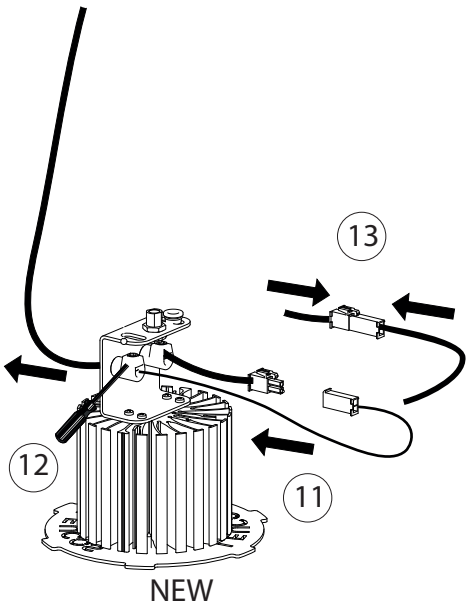
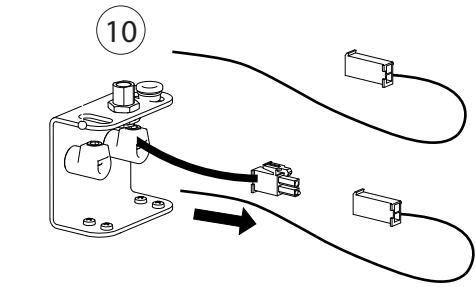
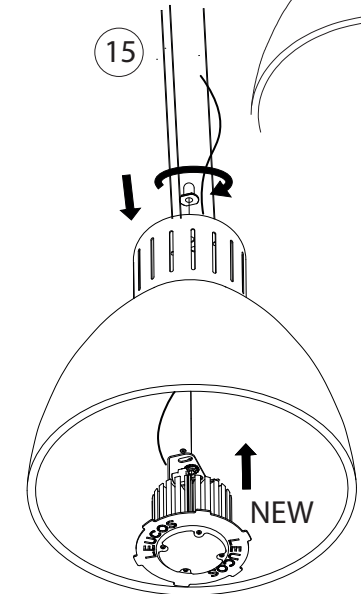
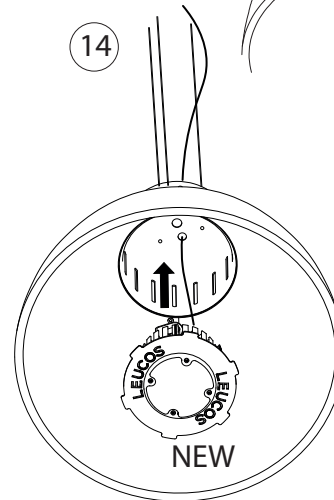
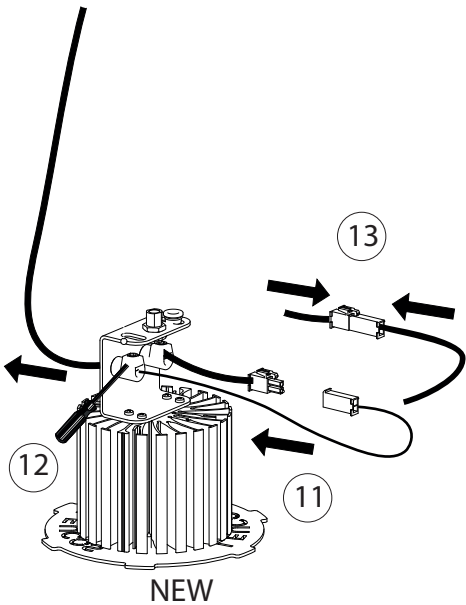
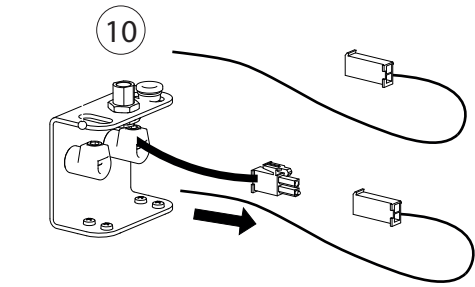
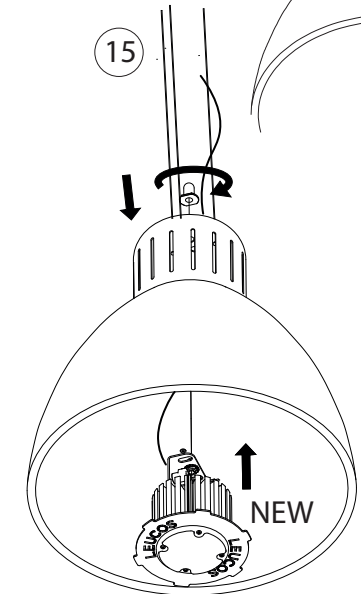
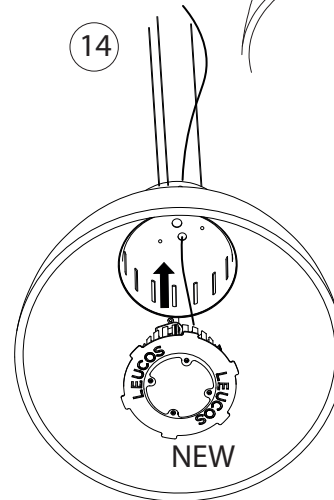
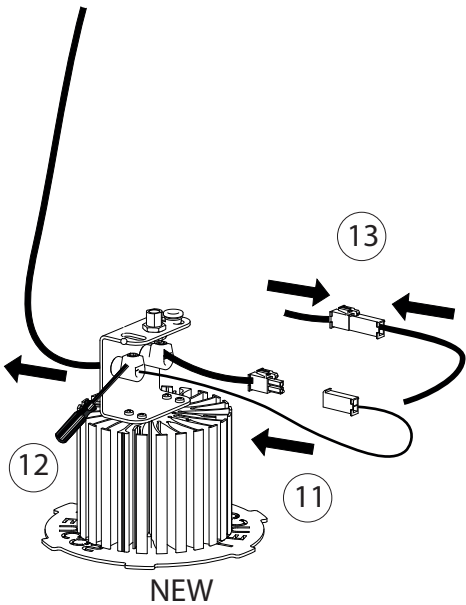
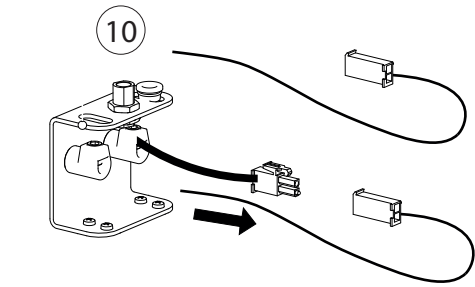
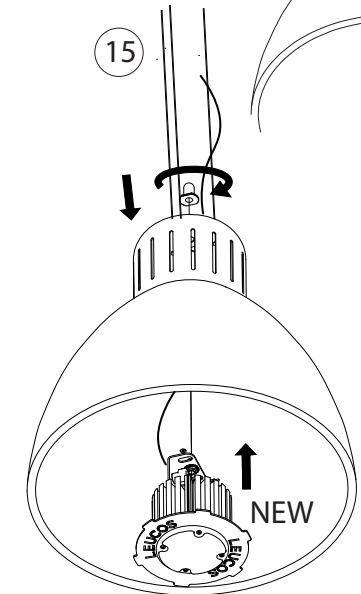
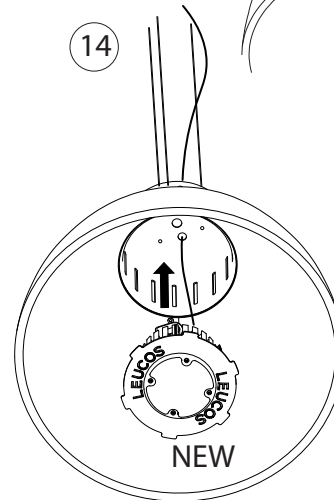
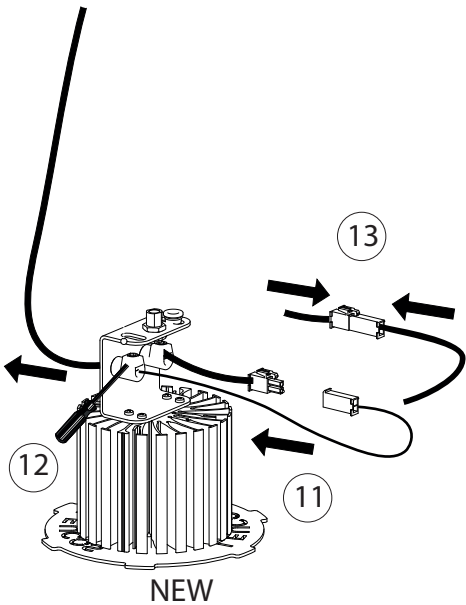
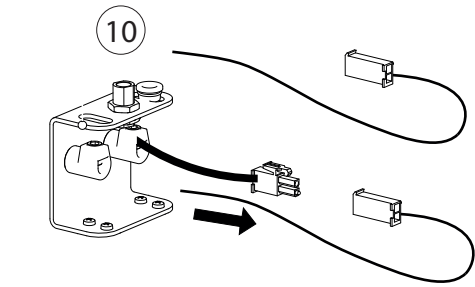
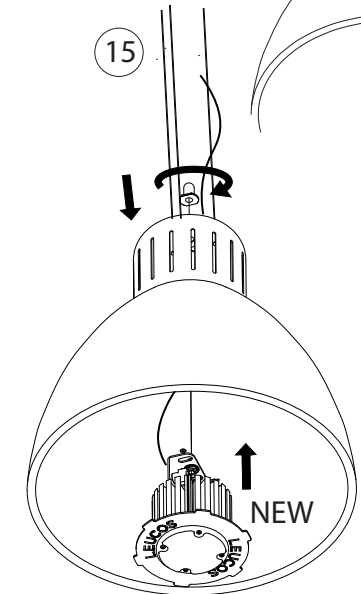
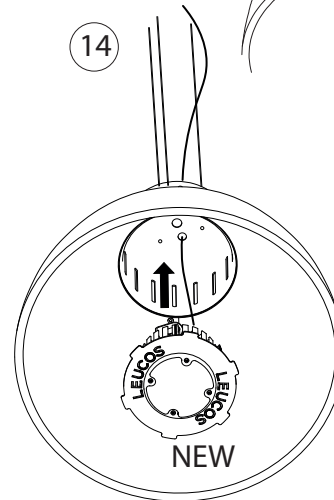
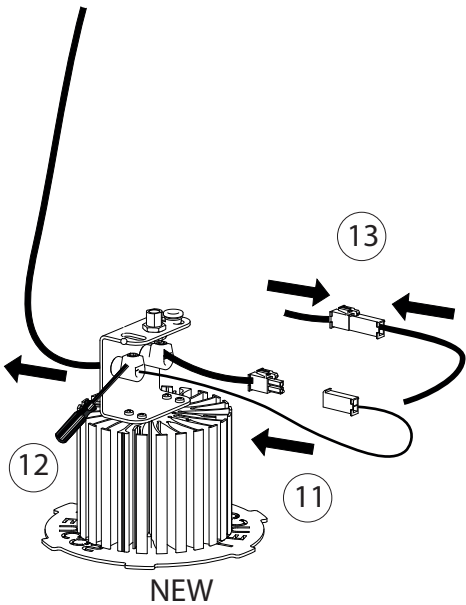
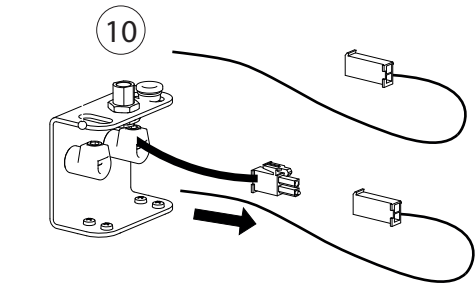
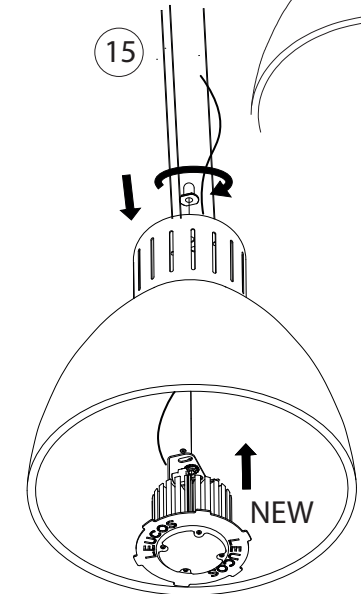
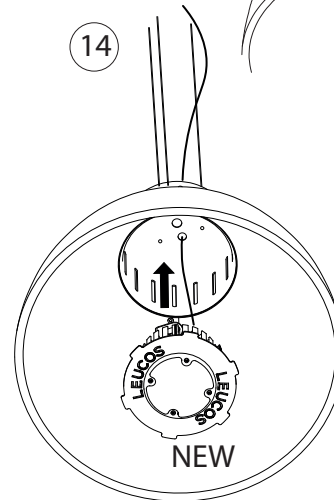
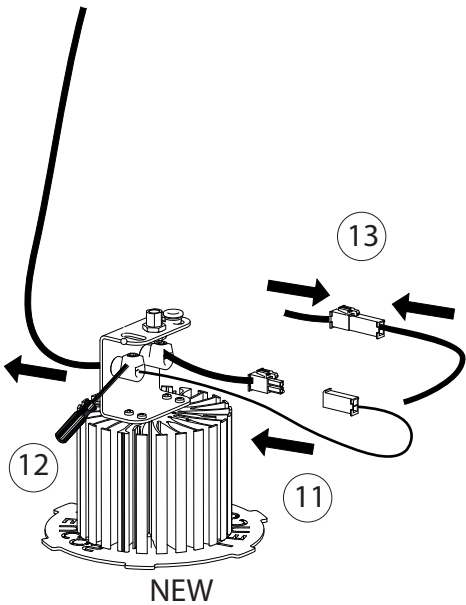
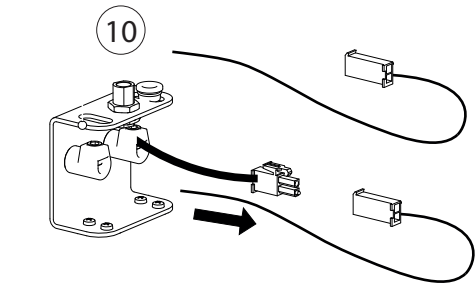
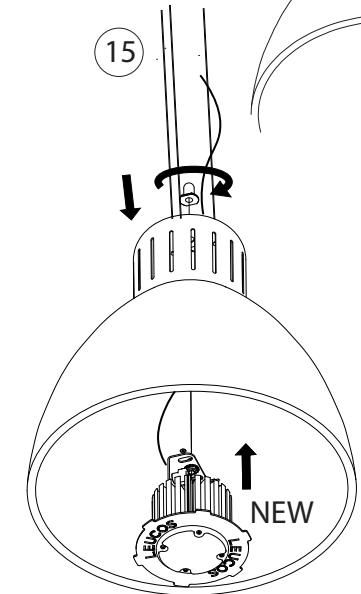
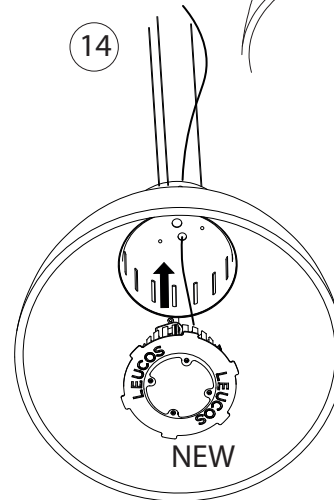
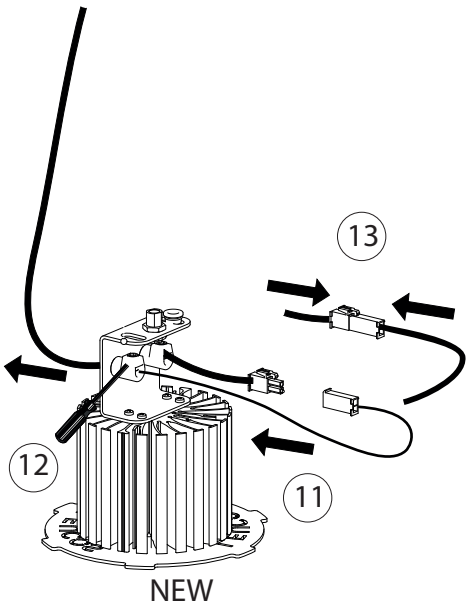
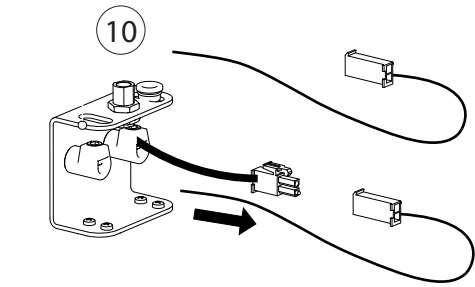
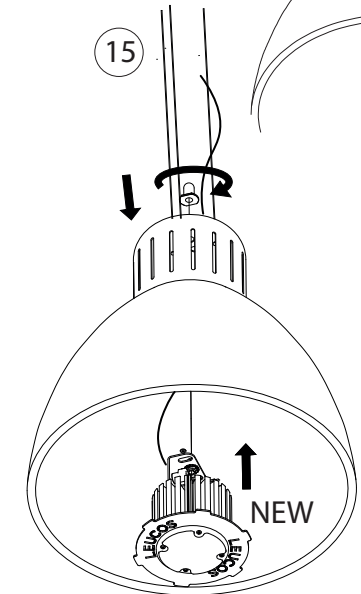
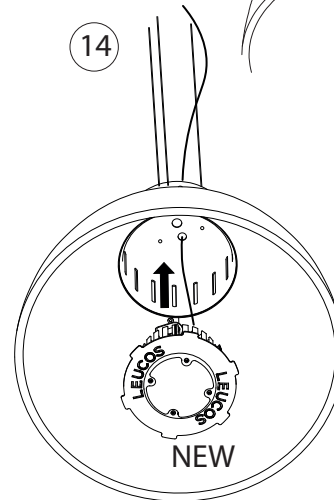
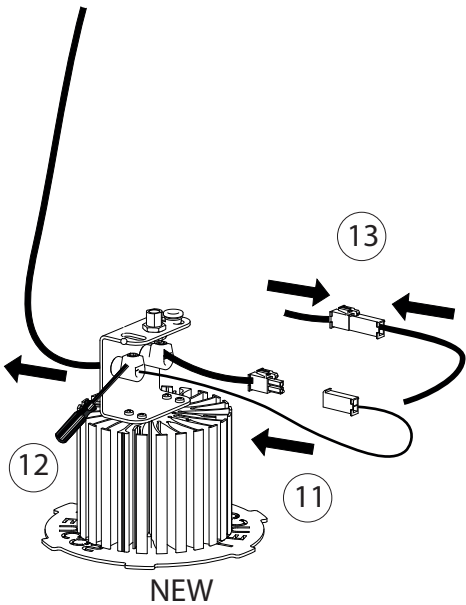
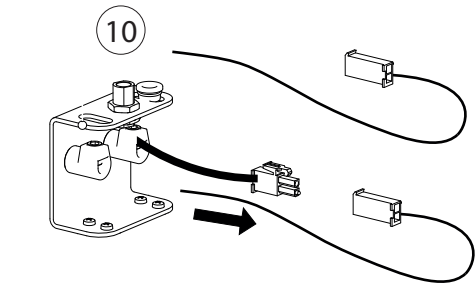
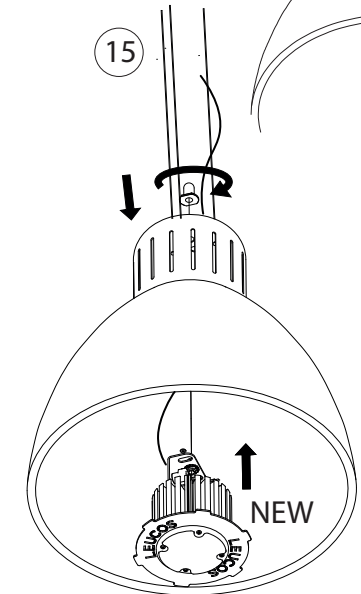
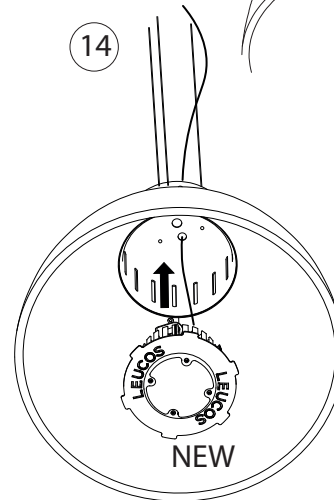
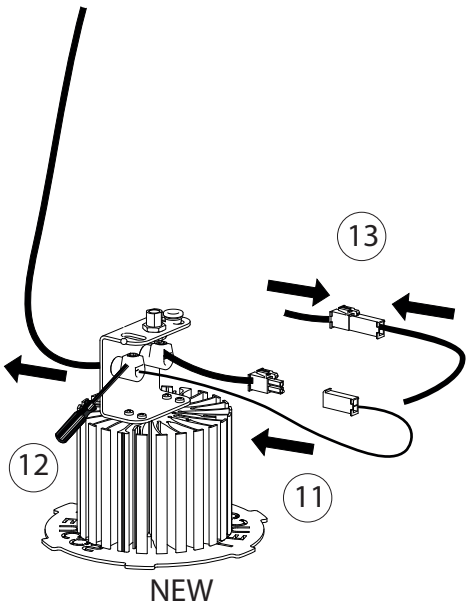
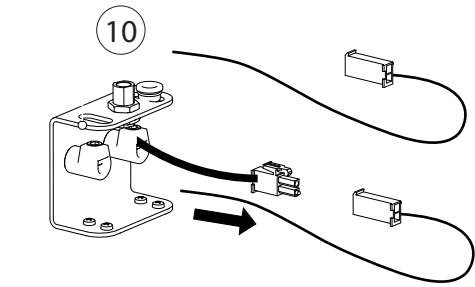
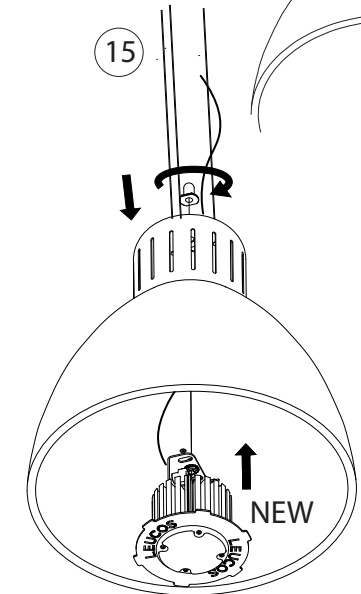
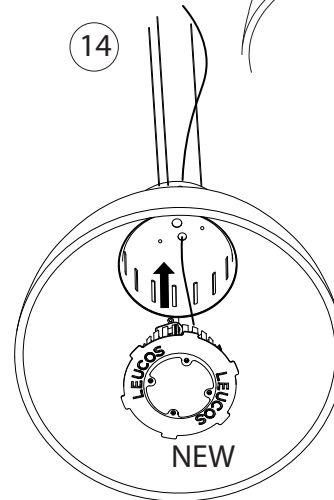
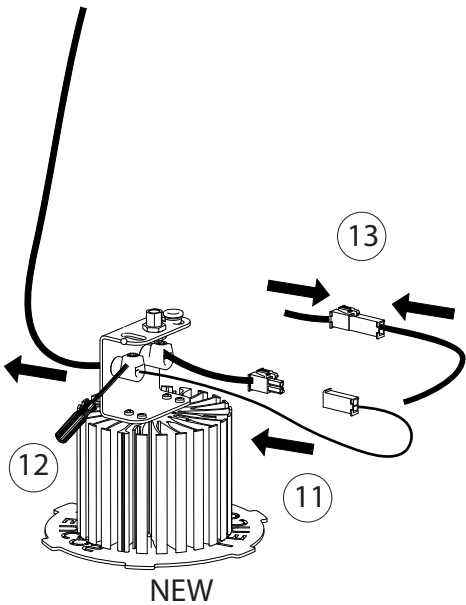
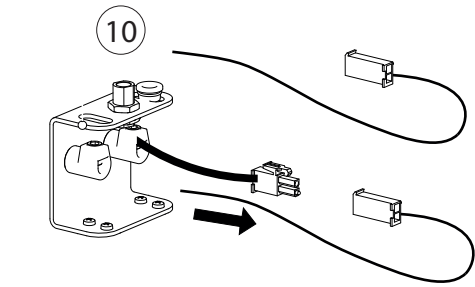
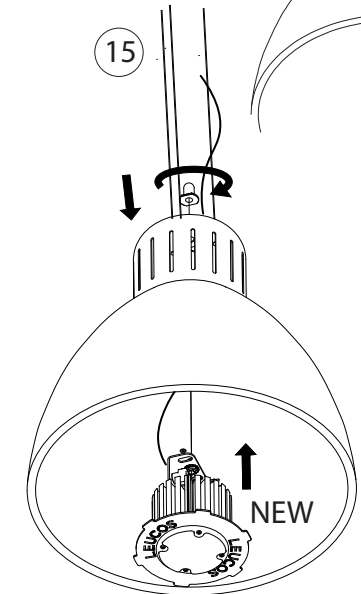
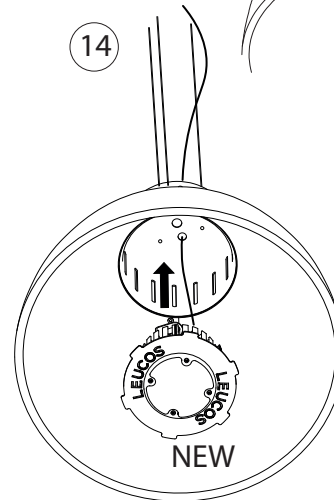
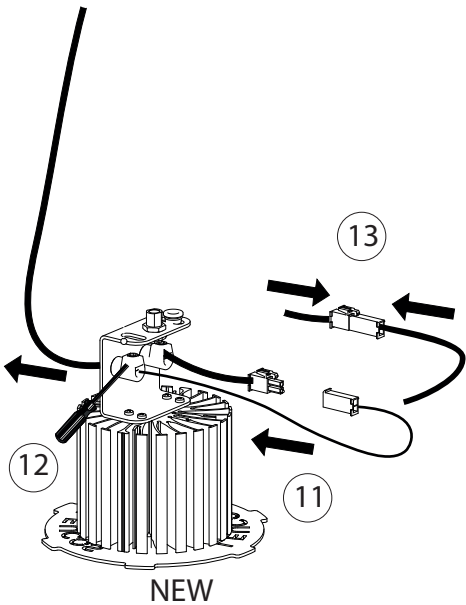
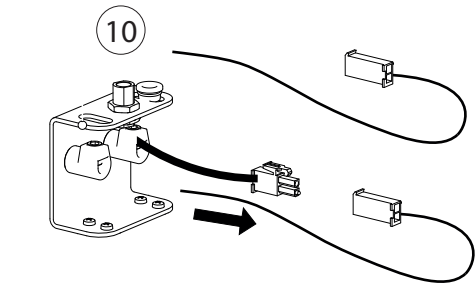
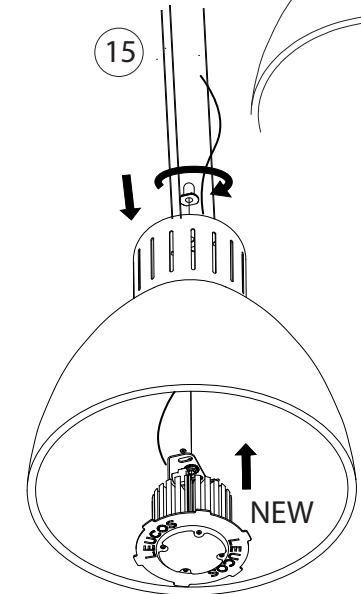
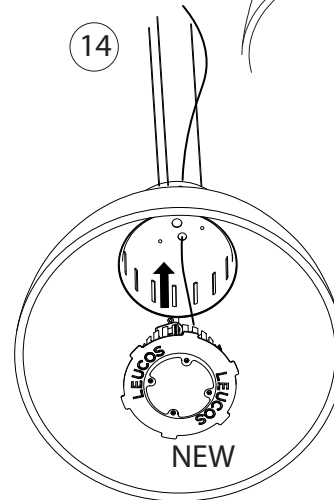
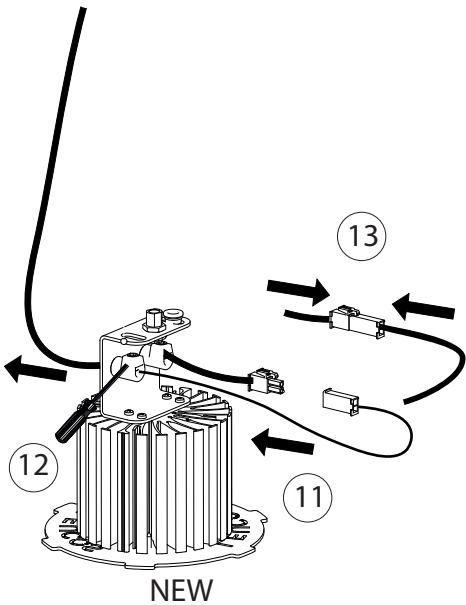
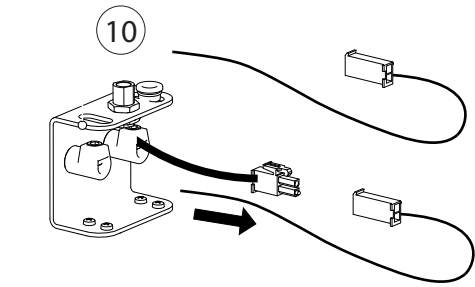
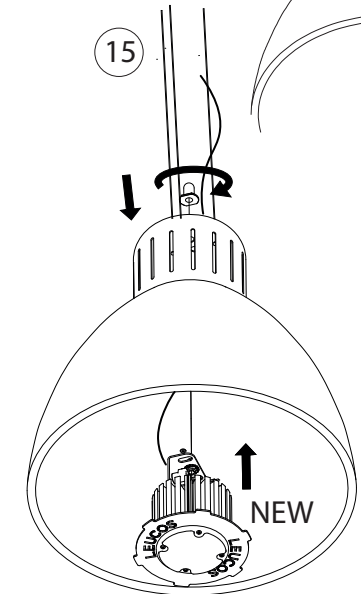
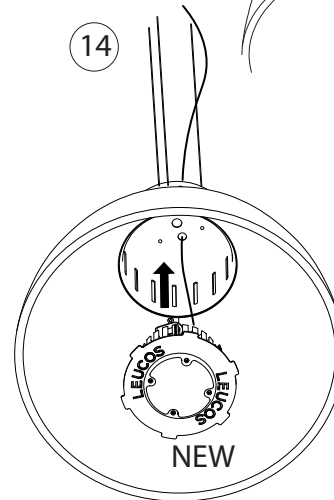
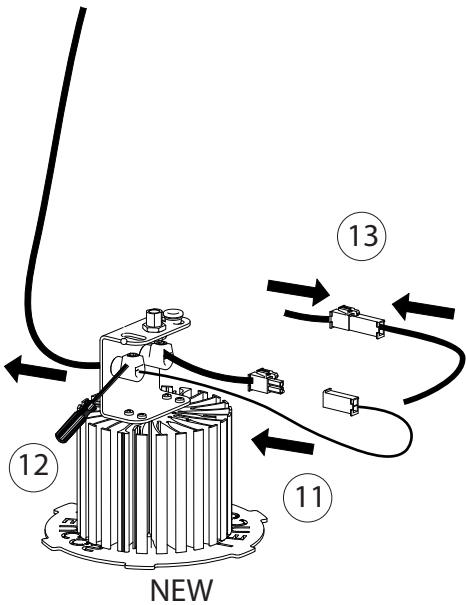
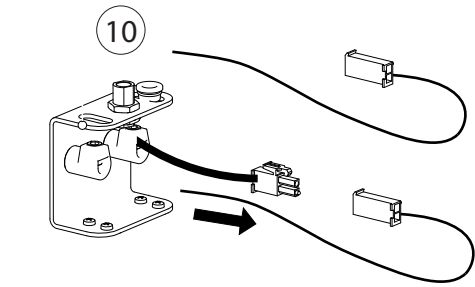
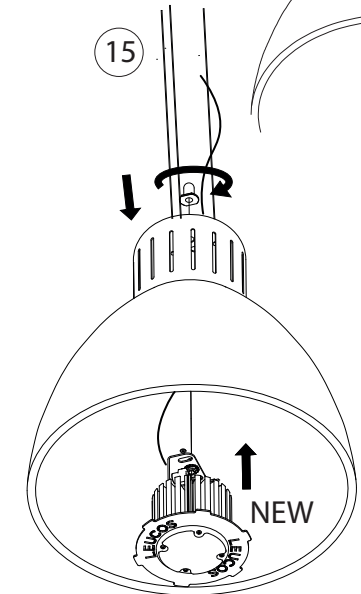
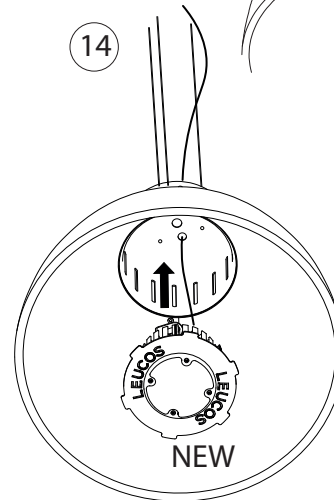
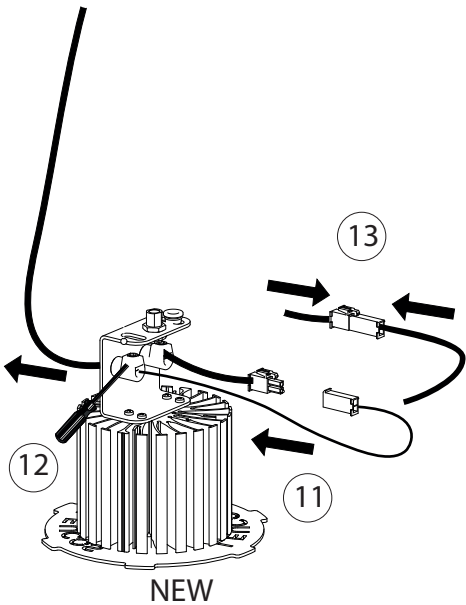
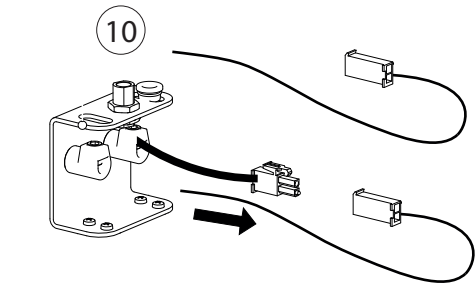
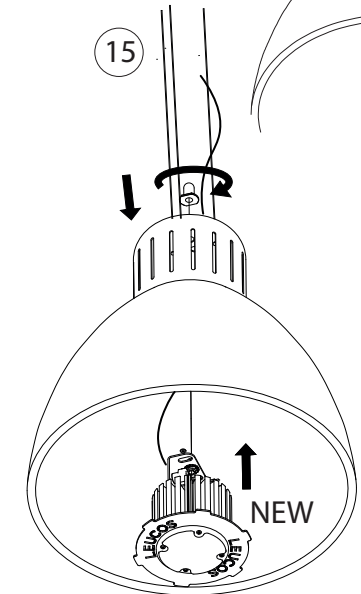
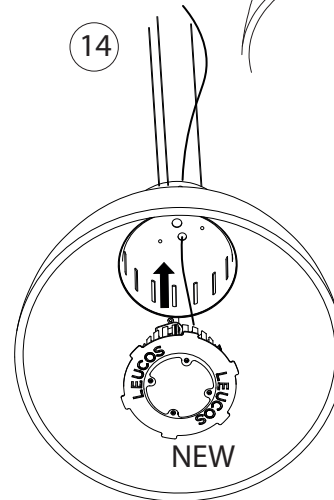
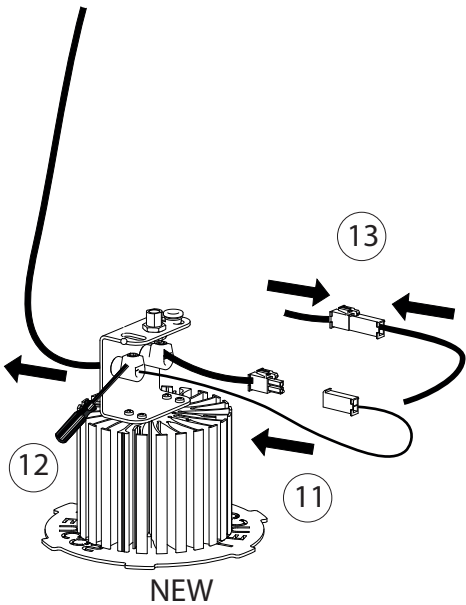
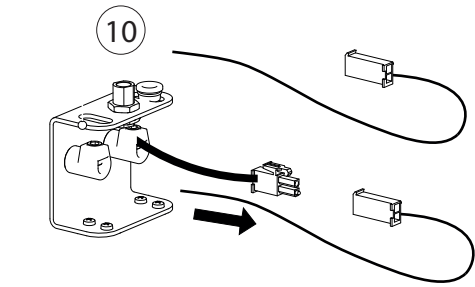
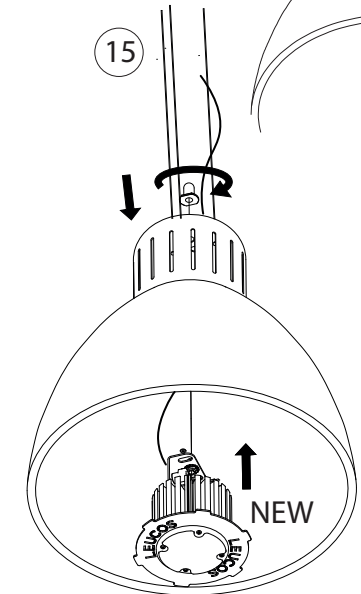
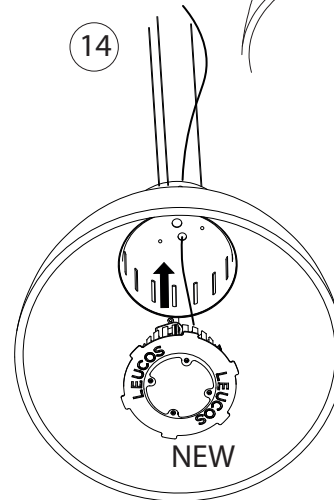
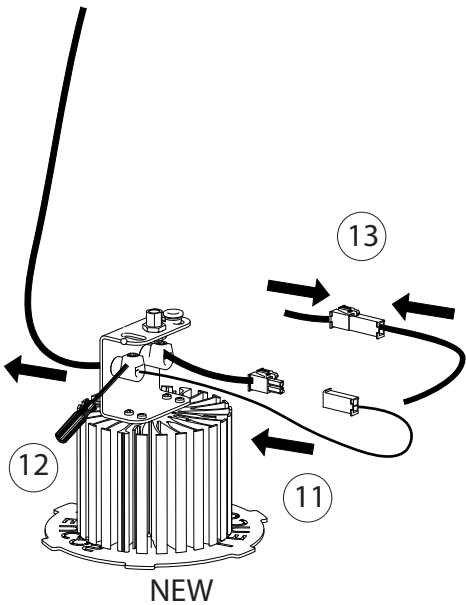
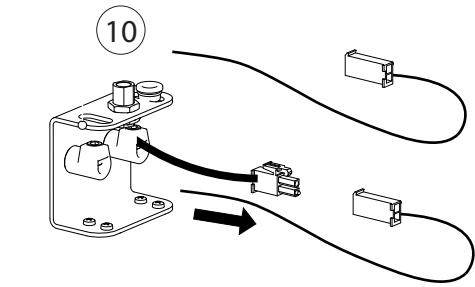
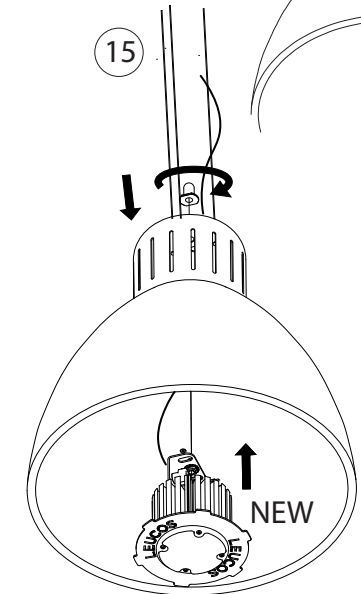
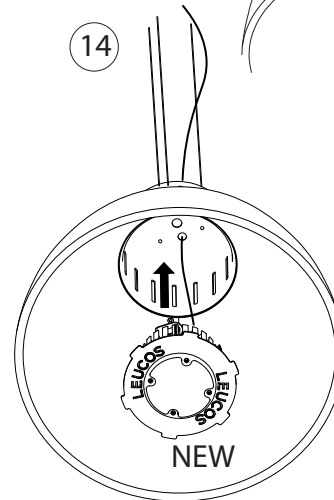
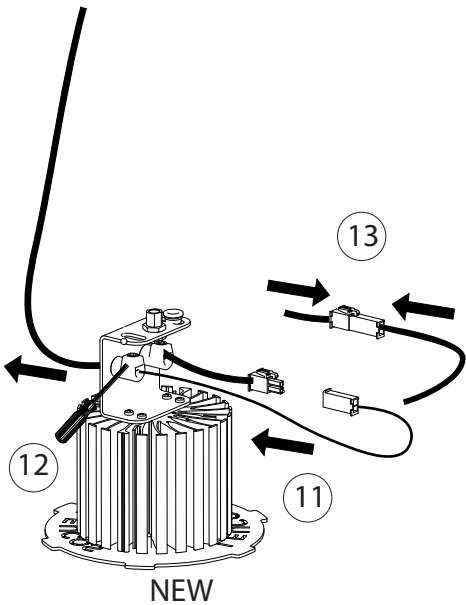
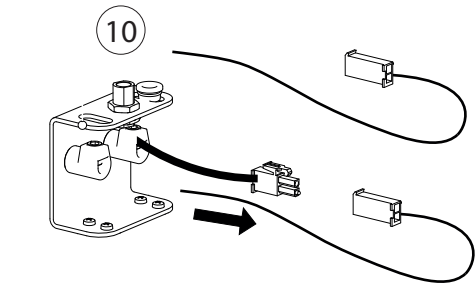
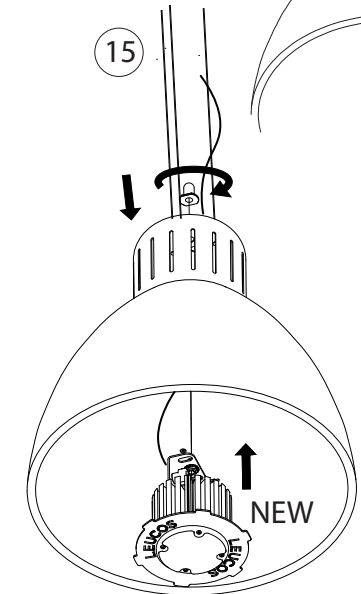
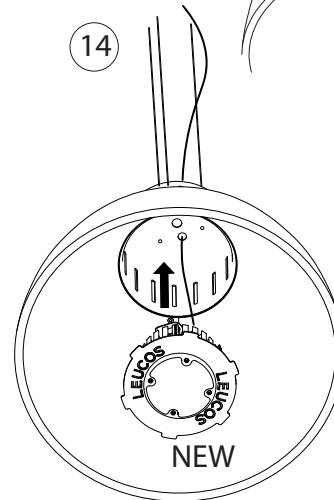
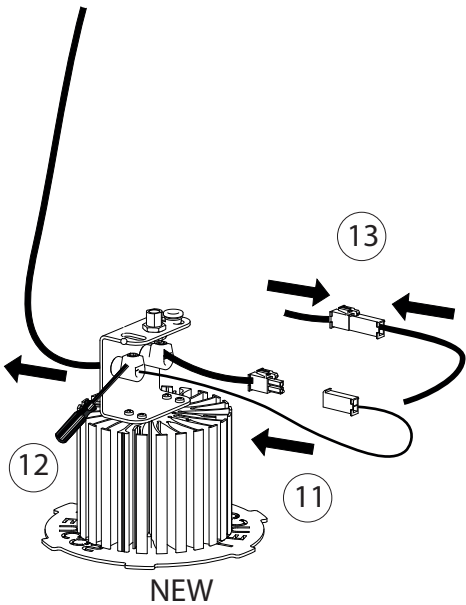
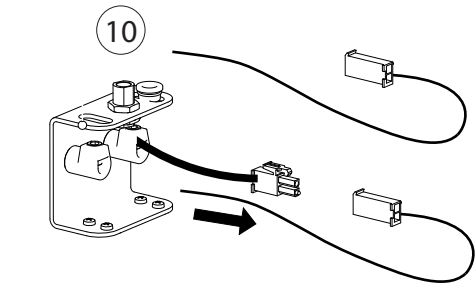
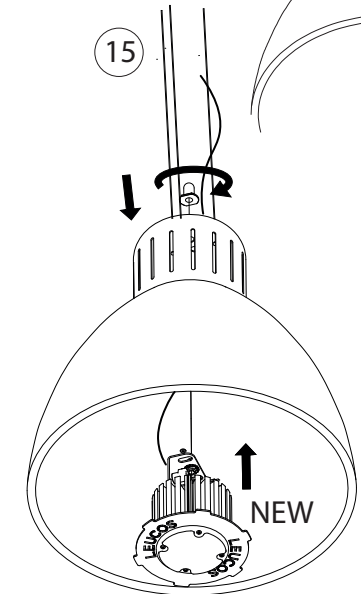
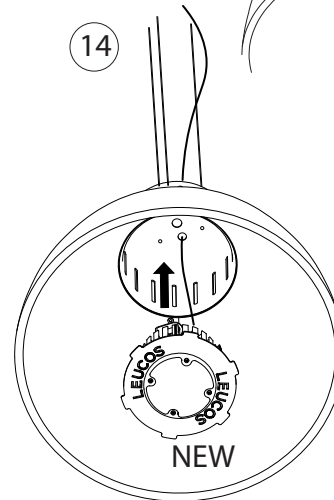
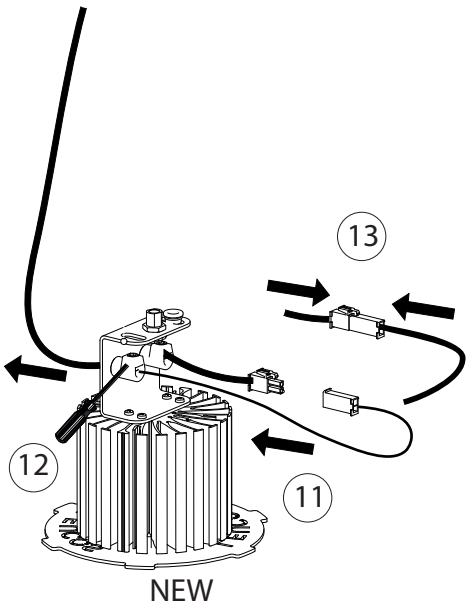
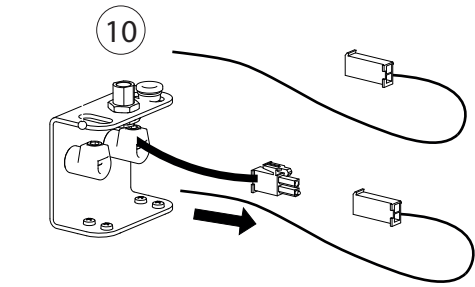
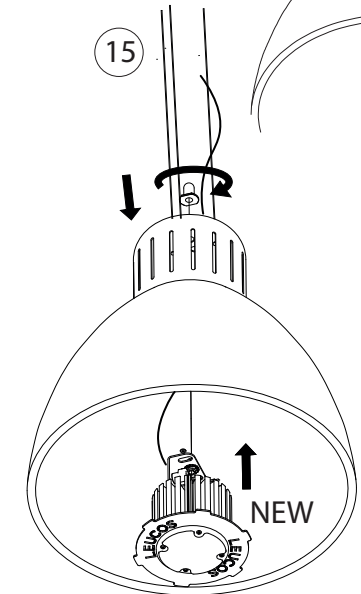
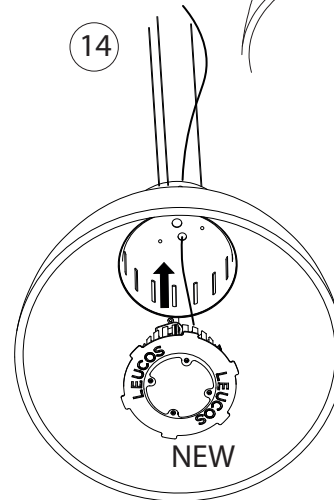
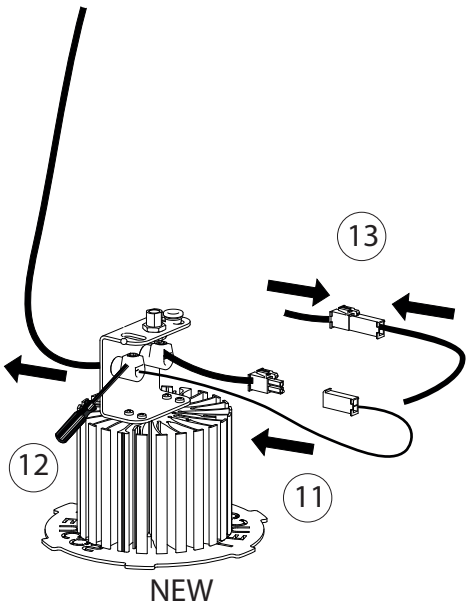
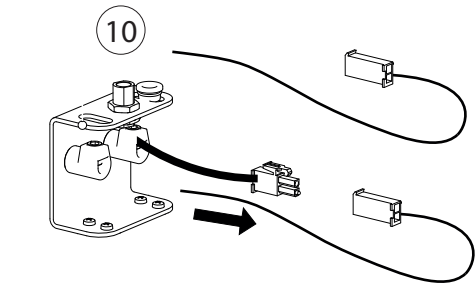
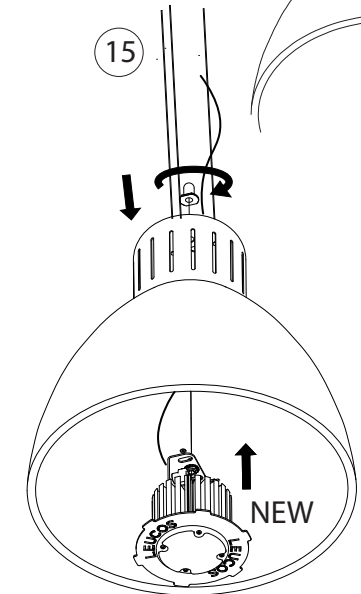
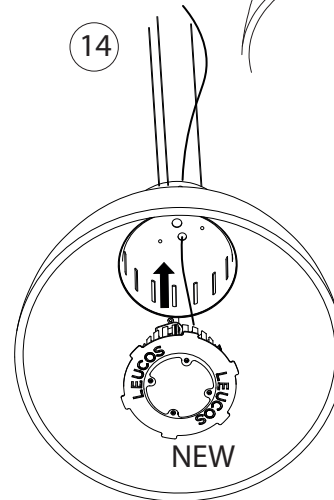
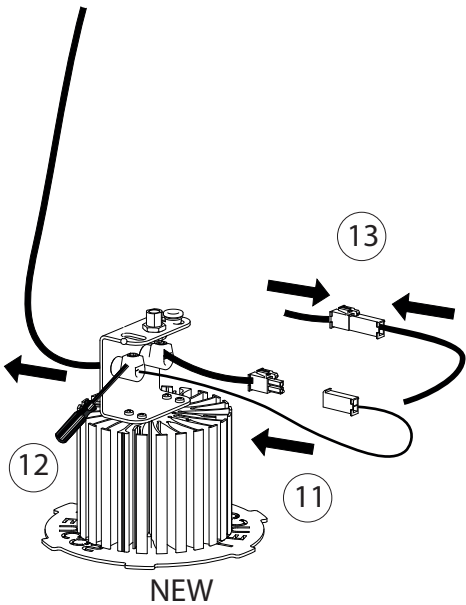
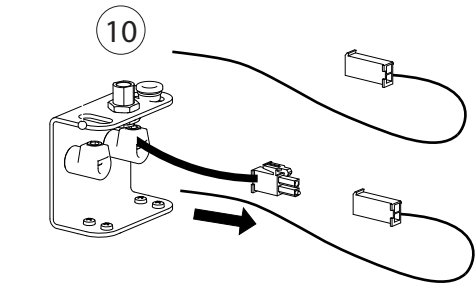
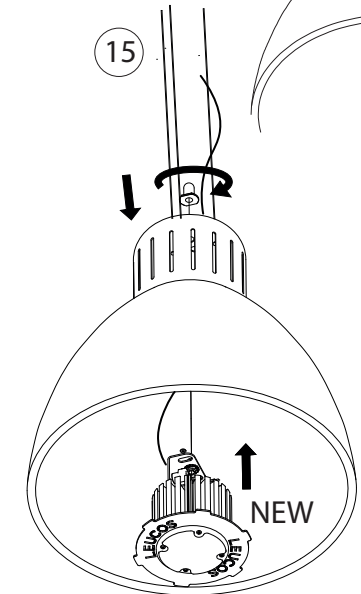
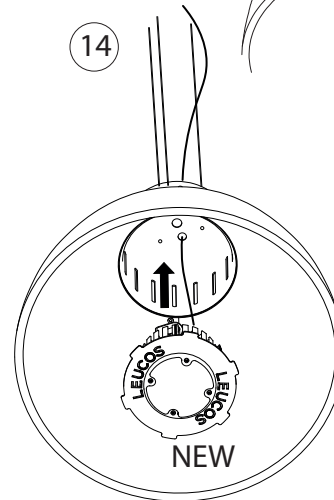
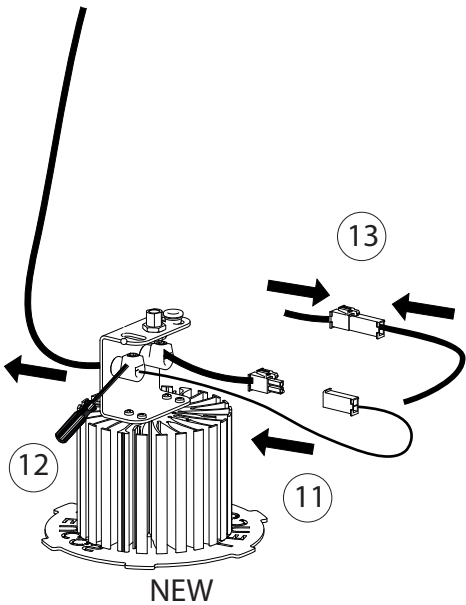
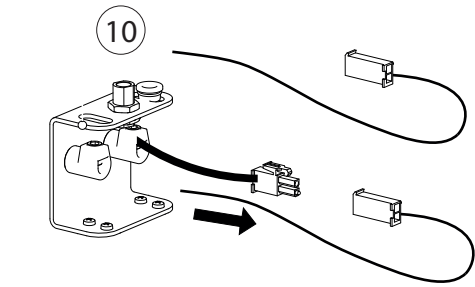
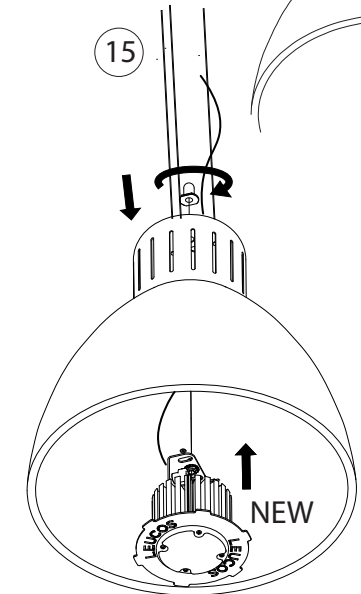
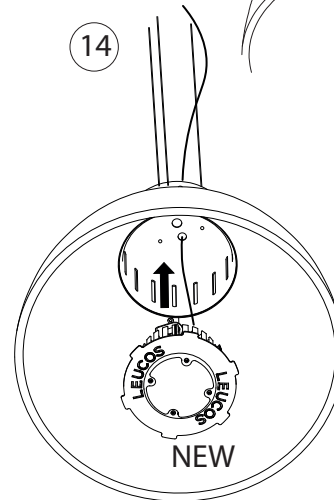
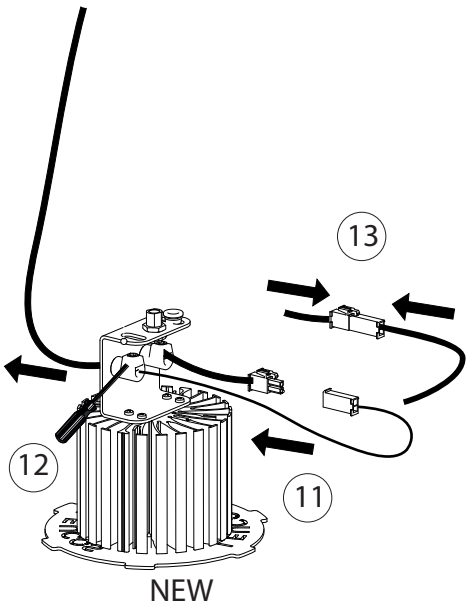
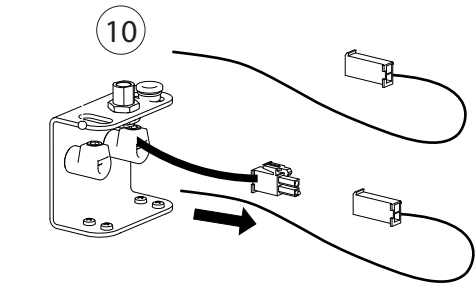
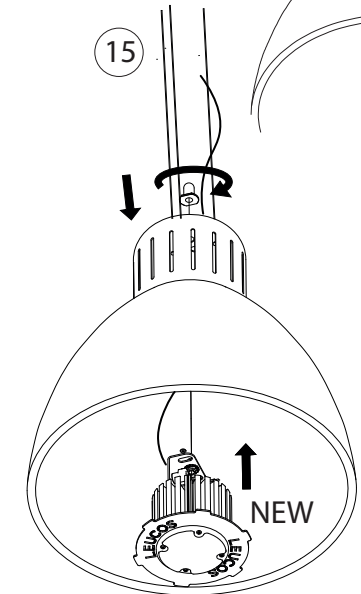
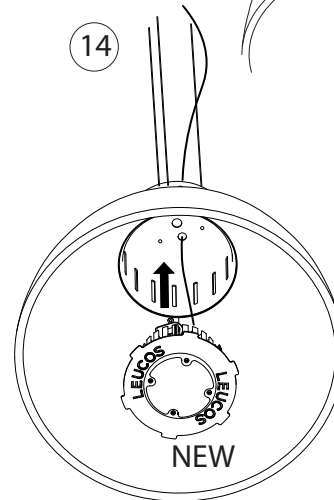
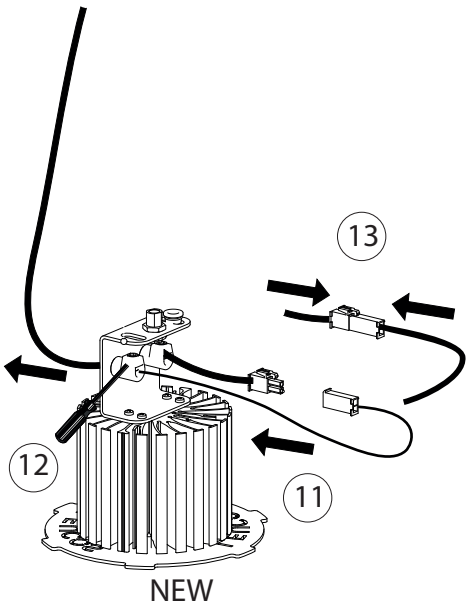
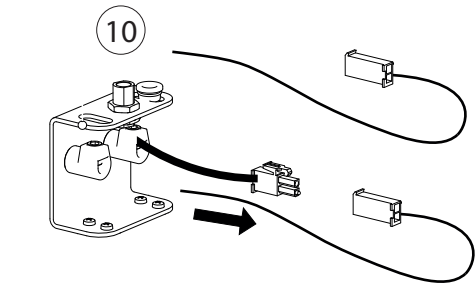
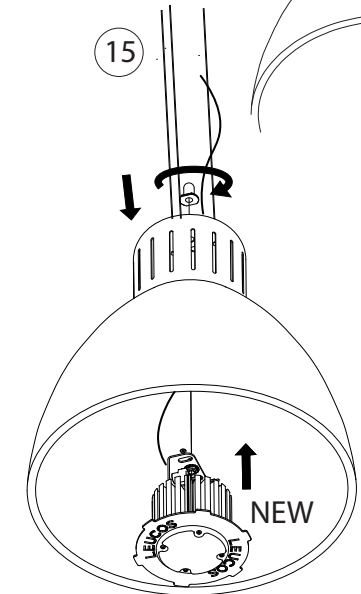
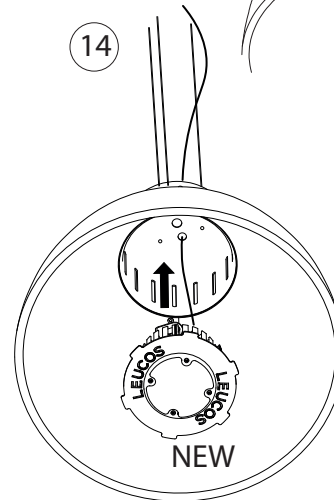
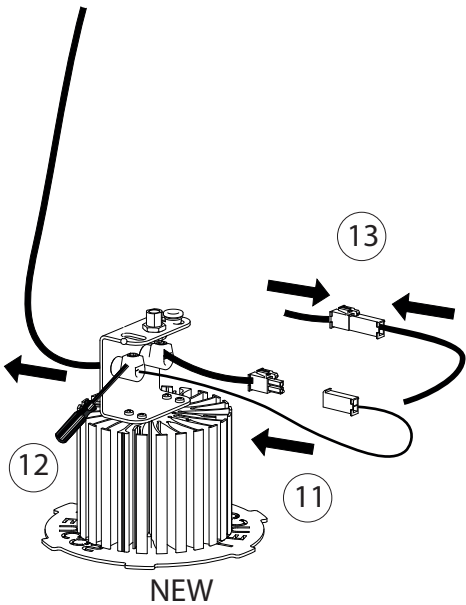
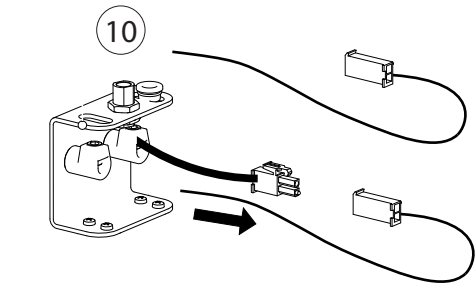
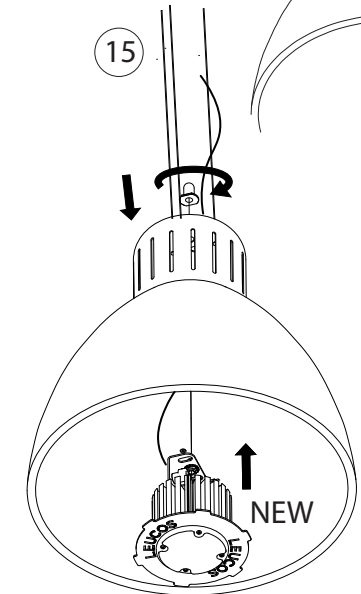
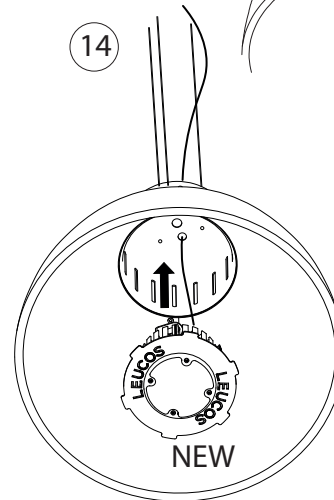
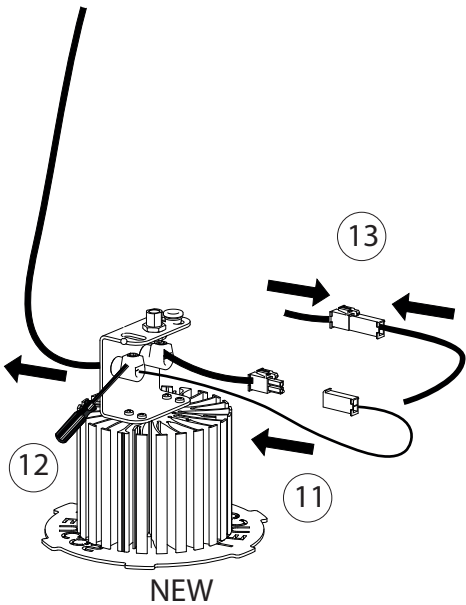
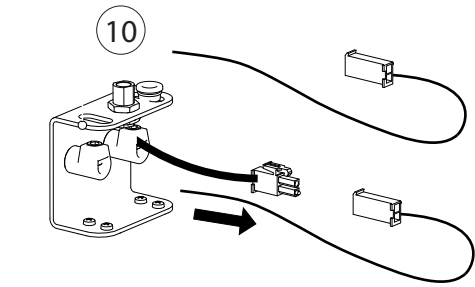
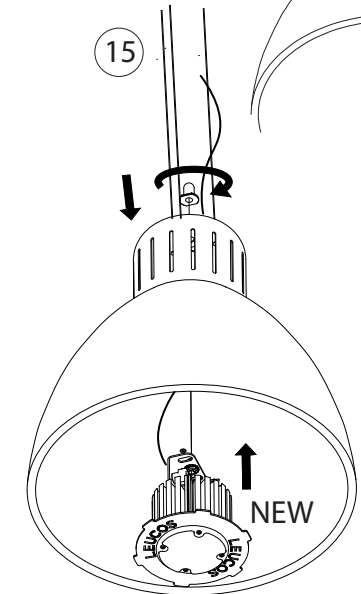
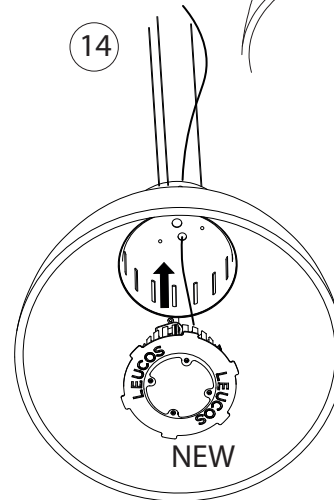
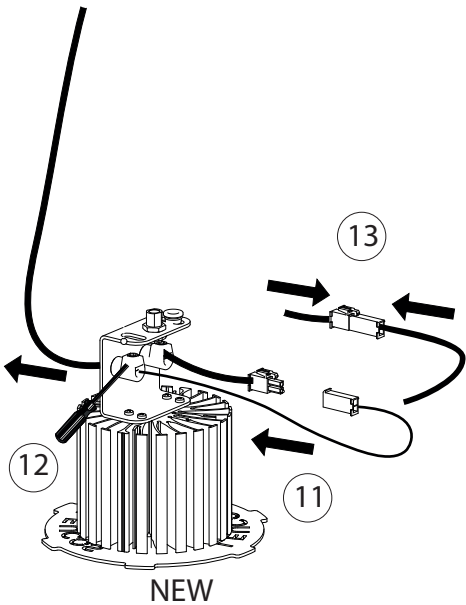
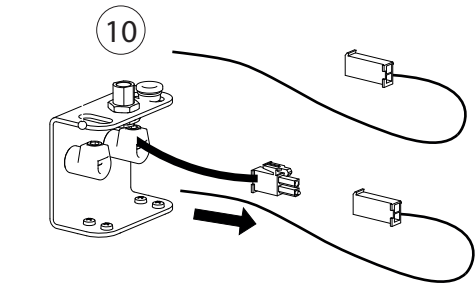
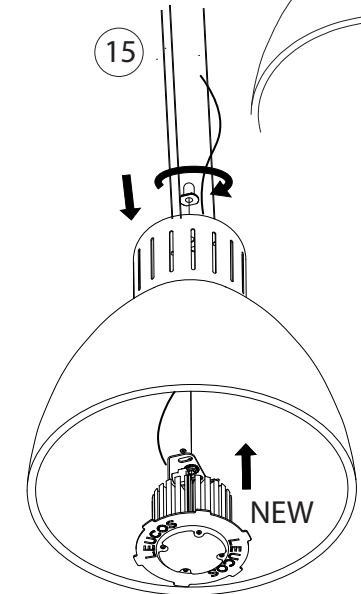
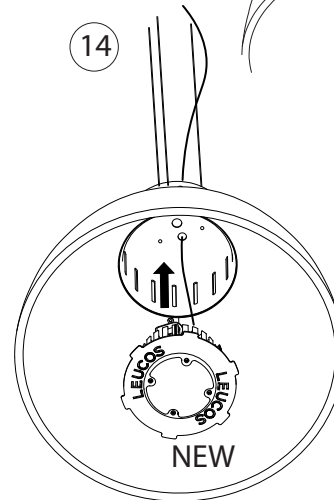
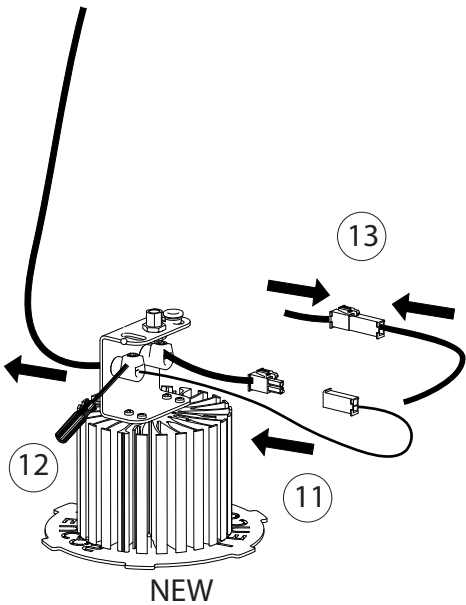
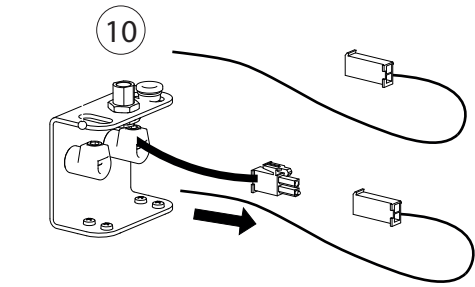
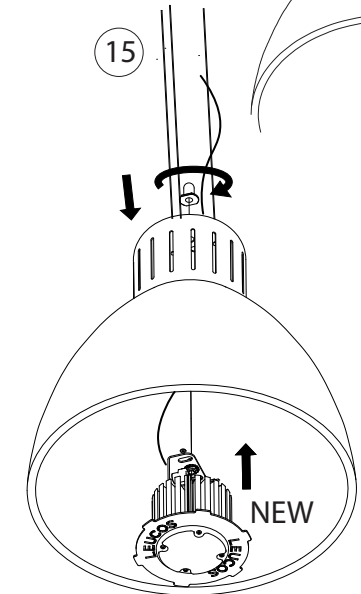
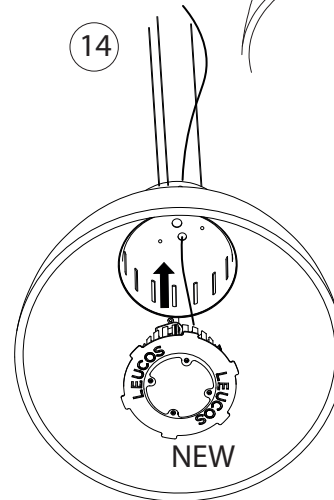
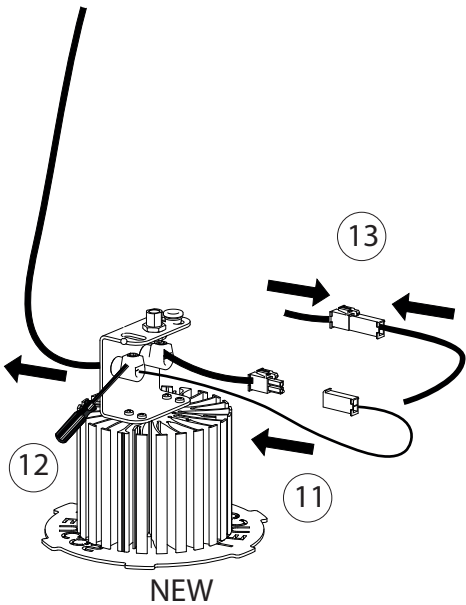
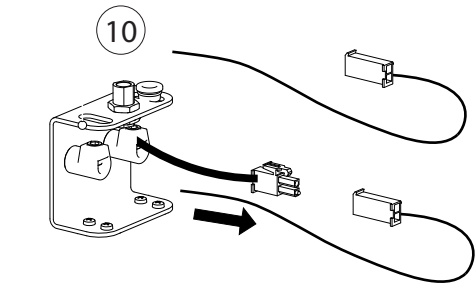
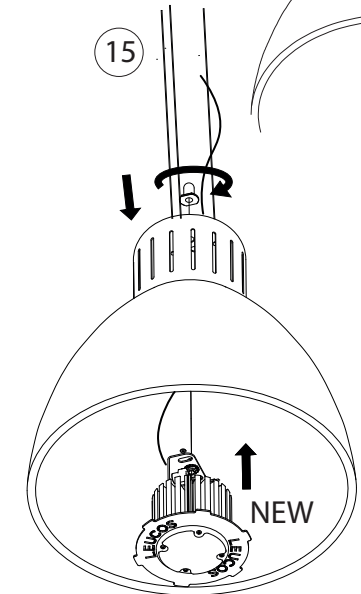
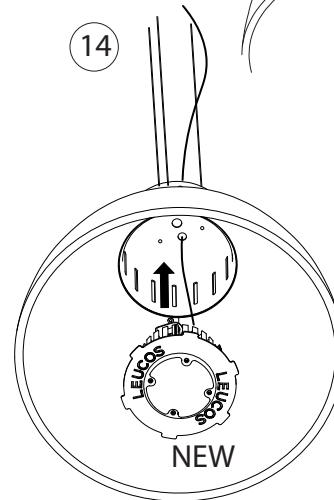
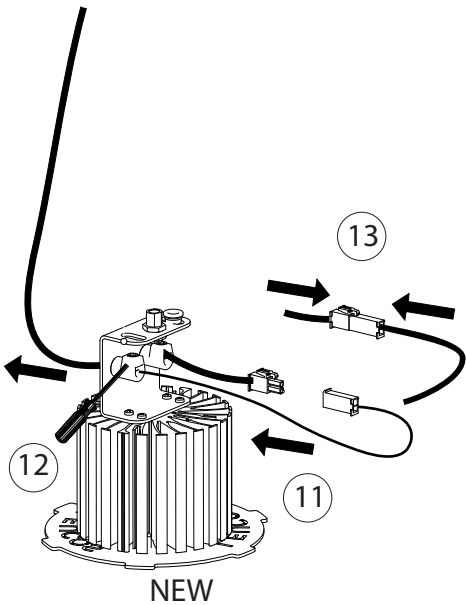
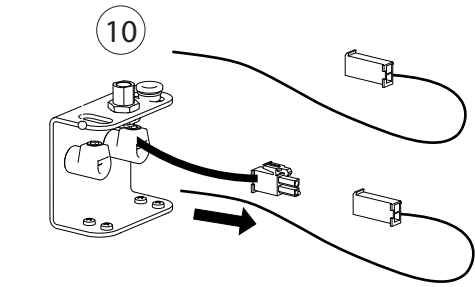
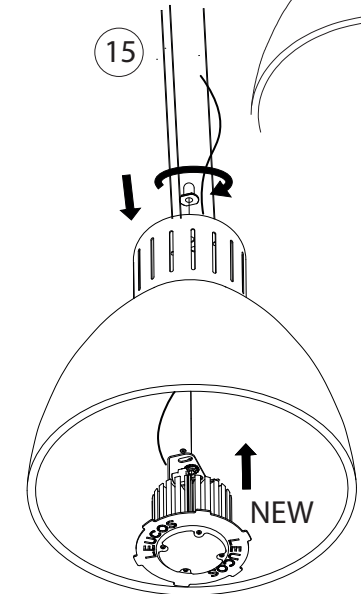
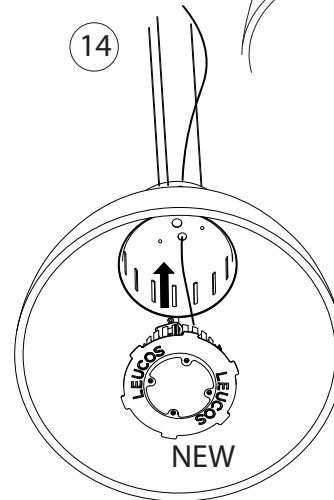
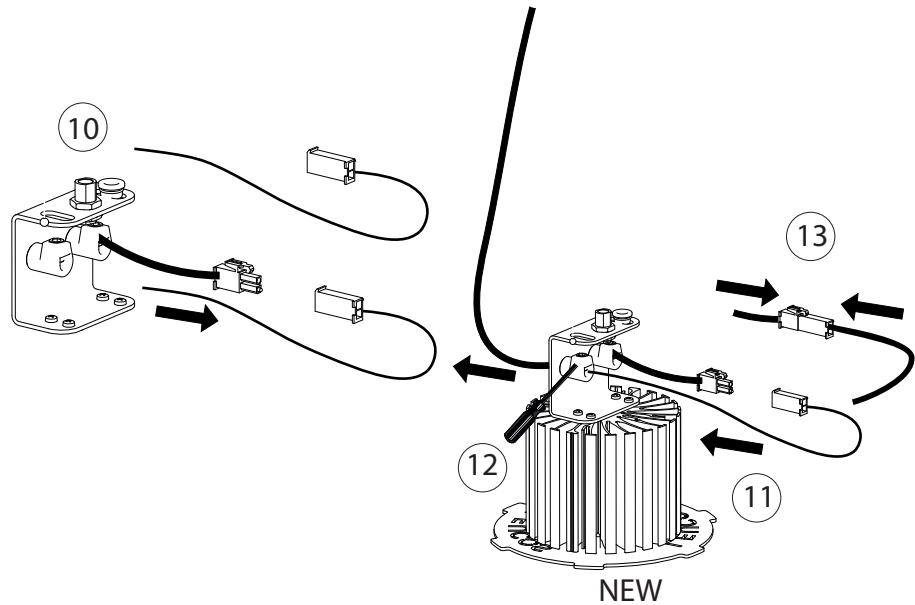
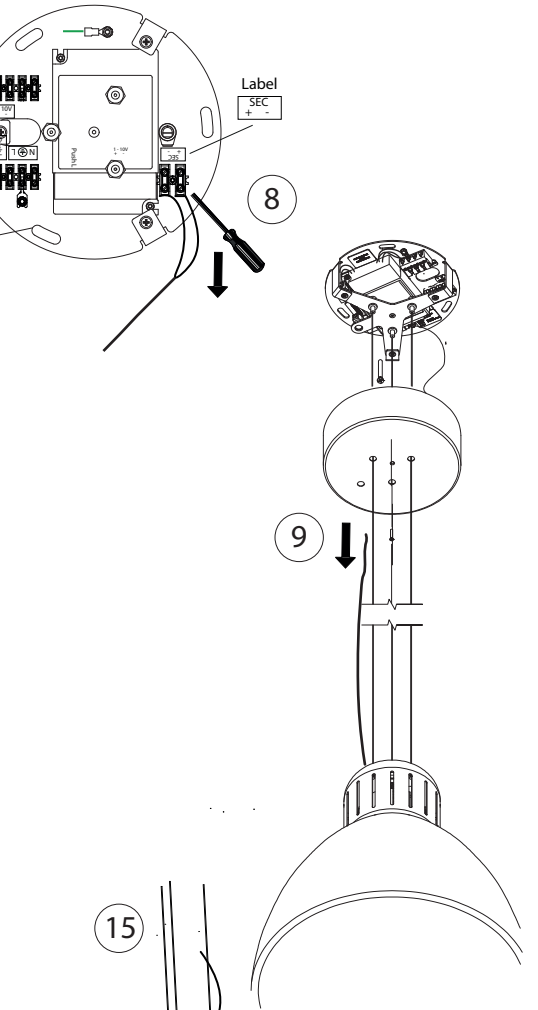
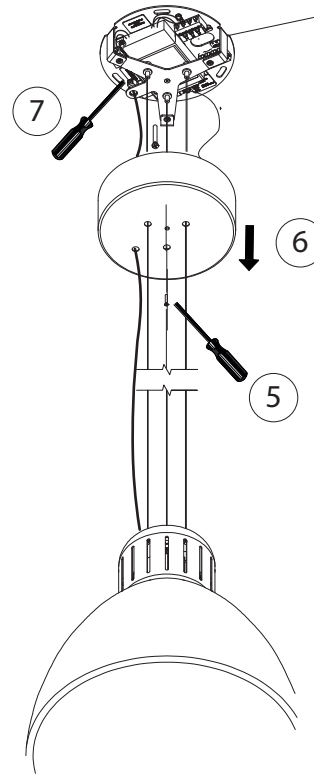
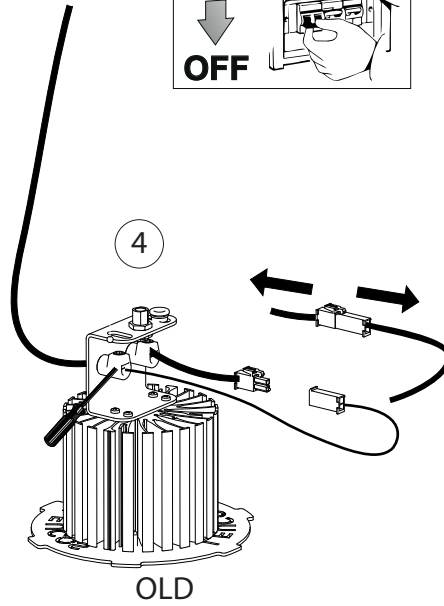
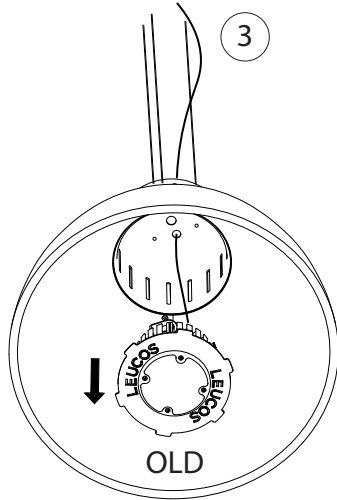
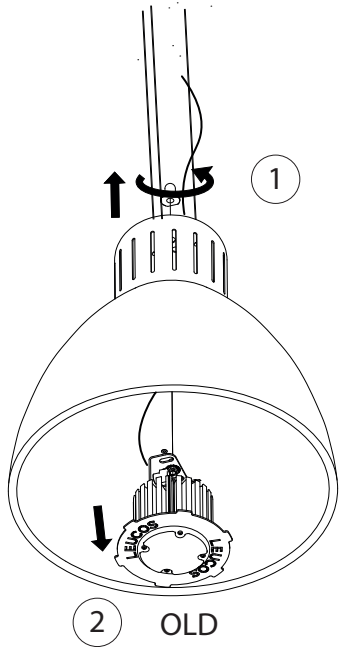
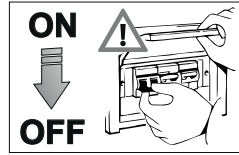

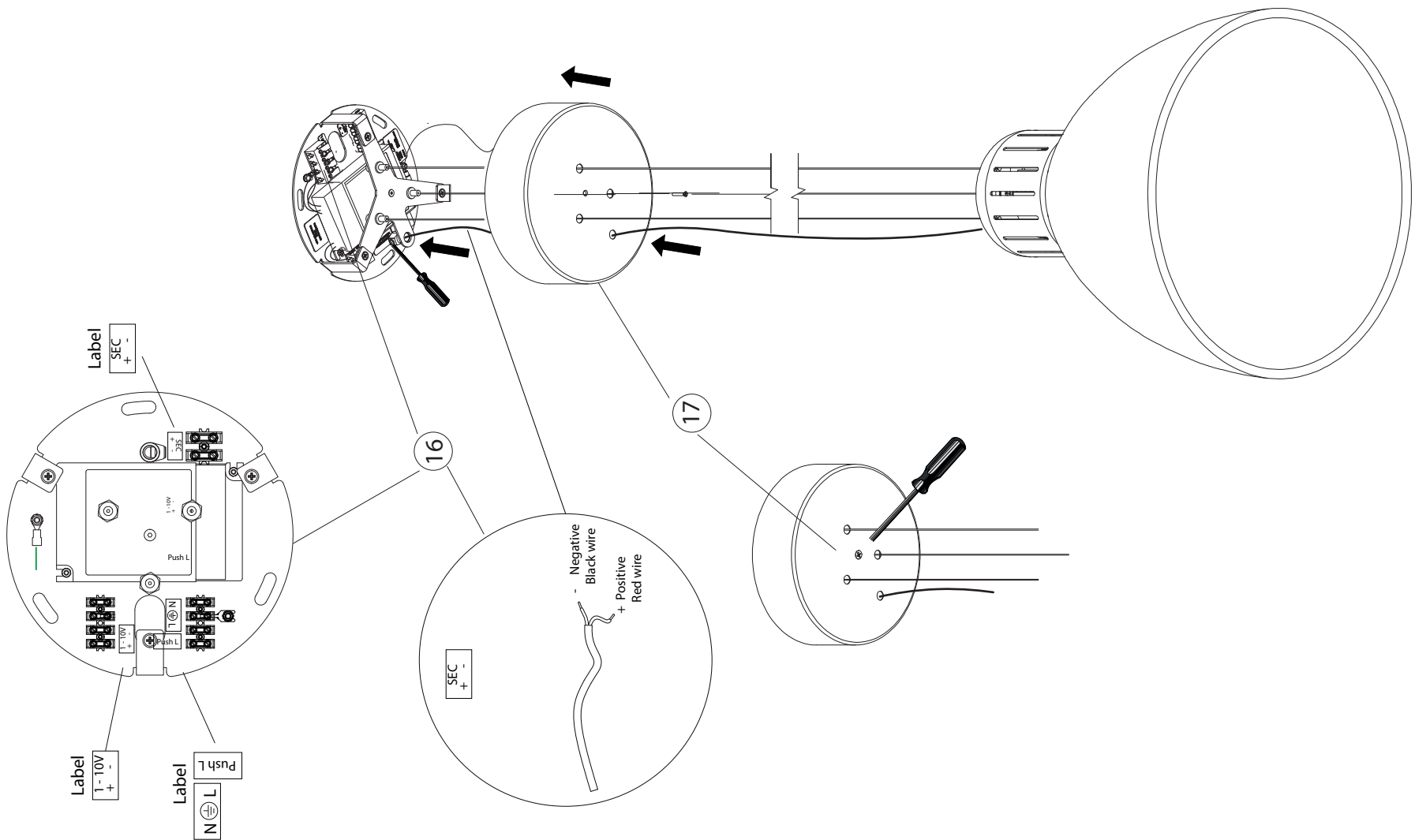



#### Smaltimento dell'apparecchio

Una volta giunto a fine vita, l'apparecchio di illuminazione è considerato un rifiuto rientrante nella categoria RAEE (Rifiuti di Apparecchiature Elettriche ed Elettroniche), pertanto non deve essere smaltito come un rifiuto domestico, si deve invece provvedere al suo corretto smaltimento per evitare danni all'ambiente, alle persone e agli animali, ed evitare lo spreco di materiali riciclabili. È possibile consegnare il vecchio apparecchio al venditore nel momento in cui si acquista un nuovo apparecchio di illuminazione, oppure portarlo nei centri di raccolta differenziata predisposti dalle amministrazioni comunali, o depositarlo negli appositi contenitori.

#### Disposal of the luminaire.

At the end of its working life, this luminaire is considered WEEE (Waste Electrical and Electronic Equipment) and therefore must not be disposed of as household waste. Rather, it must be disposed of correctly to prevent harming the environment, people and animals, and avoid wasting recyclable materials. The old luminaire can be taken back to the reseller when purchasing a new one, or alternatively it can be taken to a council waste recycling centre or placed in the special containers provided.

#### Entsorgung des Gerätes

Wenn ein Beleuchtungsgerät ausgedient hat, fällt es unter die Kategorie der Elektround Elektronikaltgeräte (WEEE) und gehört daher nicht in den Hausmüll, sondern muss vorschriftsmäßig entsorgt werden, um Umwelt, Personen und Tiere nicht zu schädigen sowie Wertstoffe nicht zu vergeuden. Beim Kauf eines neuen Beleuchtungsgerätes kann das alte Gerät dem Händler übergeben oder den von den Gemeindeverwaltungen eingerichteten getrennten Sammlungen zugeführt bzw. in den entsprechenden.

#### Containern abgelegt werden.

Elimination de l'appareil En fin de vie l'appareil d'éclairage est considéré comme un DEEE (Déchet d'équipements électriques et électroniques) et ne doit pas être éliminé avec les déchets ménagers. Il doit être éliminé de manière appropriée afin de préserver l'environnement et ne pas mettre en danger la santé humaine et animale, et de valoriser au mieux les matériaux recyclables. Il est possible de rapporter l'ancien appareil en magasin lors de l'achat d'un nouvel appareil d'éclairage, ou de le confier à un point de collecte mis en place par les collectivités territoriales ou de le déposer dans les conteneurs prévus à cet effet.

#### Eliminación del aparato

Al final de su ciclo de vida, el aparato de iluminación ha de considerarse un residuo de la categoría RAEE (Residuos de Aparatos Eléctricos y Electrónicos) y, por consiguiente, no se ha de eliminar como un residuo doméstico y se ha de eliminar correctamente para no causar daños al medio ambiente, a las personas y a los animales, y evitar el derroche de materiales reciclables. El aparato viejo puede entregarse al vendedor al comprar un aparato nuevo de iluminación o llevarlo a un centro de recogida selectiva, predispuesto por las administraciones municipales, o depositarlo en los contenedores específicos.

## PULIZIA/CLEANING

#### PULIZIA METALLO

Pulizia della lampada: per non rovinare il metallo, utilizzare un panno morbido leggermente inumidito; non usare materiali abrasivi o solventi.

#### CLEANING THE METAL

Cleaning the lamp: to avoid damaging the metal, use a soft and slightly dampened cloth; do not use abrasive materials or solvents.

#### METALLREINIGUNG

Reinigung der Lampe: um das Glas nicht zu beschädigen, einen weichen, leicht angefeuchteten Lappen benutzen; keine scheuernden Materialien oder Lösungsmittel verwenden.

#### NETTOYAGE DU MÉTAL

Nettoyage de la lampe: pour ne pas abîmer le métal, utiliser un chiffon doux légèrement humide ; ne pas utiliser de produits abrasifs ou de solvants.

#### LIMPIEZA DEL METAL

Limpeza de la lámpara: para no dañar el metal, utilizar un paño suave ligeramente húmedo; no utilizar materiales abrasivos o disolventes.

#### PULIZIA VETRO

Pulizia della lampada: per non rovinare il vetro utilizzare un panno morbido leggermente inumidito; non usare materiali abrasivi o solventi.

#### CLEANING THE GLASS

Cleaning the lamp: to avoid damaging the glass, use a soft and slightly dampened cloth; do not use abrasive materials or solvents.

#### GLASREINIGUNG

Reinigung der Lampe: um das Glas nicht zu beschädigen, einen weichen, leicht angefeuchteten Lappen benutzen; keine scheuernden Materialien oder Lösungsmittel verwenden.

#### NETTOYAGE DU VERRRE

Nettoyage de la lampe : pour ne pas abîmer le verre utiliser un chiffon doux légèrement humide ; ne pas utiliser de produits abrasifs ou de solvants.

#### LIMPIEZA DEL VIDRIO

Limpeza de la lámpara: para no estropear el vidrio, usar un paño suave ligeramente húmedo; no usar materiales abrasivos o disolventes.



#### Apparecchio di classe I

La sicurezza viene garantita con la messa a terra.

#### Class I luminaire

Safety is guaranteed when earthed.

#### Gerät der Schutzklasse I

Die Sicherheit wird durch Erdung garantiert.

#### Appareil de classe I

La sécurité est garantie par la mise à la terre.

#### Aparato de clase I

La seguridad se garantiza con la puesta a tierra.



#### Apparecchio in classe II

Apparecchio nel quale la protezione contro la scossa elettrica non si basa unicamente sull'isolamento principale, ma anche sulle misure supplementari di sicurezza costituite dal doppio isolamento o dall'isolamento rinforzato.

#### Fixture class II

A fixture where protection against electric shock does not rely only on the main insulation but also further safety measures involving double insulation or reinforced insulation.

#### Leuchten der Schutzklasse II

Gerät, bei dem der Schutz gegen Stromschläge nicht nur auf der Hauptisolierung beruht, sondern auch auf zusätzlichen Sicherheitsmaßnahmen, die in einer doppelten Isolierung oder einer verstärkten Isolierung bestehen.

#### Luminaire classe II

Luminaire dans lequel la protection contre le choc électrique ne se base pas uniquement sur l'isolation principale, mais également sur les mesures de sécurité supplémentaires constituées d'une double isolation ou d'une isolation renforcée.

#### Aparado de clase II

Aparato en el que la protección contra la sacudida eléctrica no se basa únicamente en el aislamiento principal sino también en las medidas adicionales de seguridad constituidas por el aislamiento doble y el aislamiento reforzado.



La marcatura indica che il prodotto ha superato positivamente tutte le prove previste dalle normative per la sicurezza elettrica, richieste dalla Comunità Europea. Normative EN 60598-1 corrispondenti alle norme Italiane per la sicurezza elettrica CEI 34-21

This mark guarantees that the product has passed all the tests established for electrical safety standards by the European Community

Die CE-Kennzeichnung bestätigt, dass das Produkt alle von den Vorschriften für die elektrische Sicherheit vorgegebenen Tests erfolgreich bestanden hat, die von der Europäischen Gemeinschaft verlangt werden

Ce marquage indique que le produit a passé tous les essais prévus par les normes pour la sécurité électrique prescrits par la Communauté Européenne

La marca indica que el producto ha superado con éxito todas las pruebas previstas por las normativas de seguridad eléctrica de la Comunidad Europeaz



etl (electrical testing laboratories)

il marchio etl identifica un prodotto in possesso dei requisiti necessari per poter essere venduto e distribuito nel territorio nordamericano poiché testato e certificato in conformità agli standard applicabili (standard ul, standard csa, ).

The etl mark identifies a product that meets the necessary requirements to be sold and distributed in North America because it has been tested and certified in accordance with applicable standards (ul standard, csa standard, ).