

LED Linear Pendant

LP90404

INSTALLATION SHEET

START FROM HERE

- Make sure **POWER** is **COMPLETELY OFF** at the fuse box
- Have your fixture installed by a qualified licensed electrician
- Prepare everything in a clear area
- Wear gloves at all times during this installation
- Read instructions carefully before you start assembly
- Keep this installation sheet for future reference

Technical Support: 1-855-855-8926

Please Note:

- This Kuzco LED fixture comes with pre-wired LED module(s)
- Unless instructed, Do Not touch any part of the LED module(s) as any unnecessary contact with the module could cause permanent damage
- For dimming, an ELV (Electronic Low Voltage) or TRIAC type of dimmer is required
- 120V input

1. Remove fixture from its original package
2. Attach strap plate (3c) to base plate (3d) with screws (3b) after pulling strap (6a) through. Attach mounting plate (1c) base plate (3d) with screws (3a) (See Illustration 2)
3. Mount inner ceiling barrel (4b) to mounting surface with anchor (4a) and screw (4c). Attach outer ceiling barrel (4d) to inner ceiling barrel (4b) with screws (4e). Pull strap (6a) to desired length and cut off any unwanted length and loop it through buckle (4g) on non-power side. Secure with screw (4f) (See Illustration 3)
4. Pull strap (6a) through pendant cap (5a) and loop it around strap disc (5c). Secure disc (5c) to pendant (5d) with screws (5b), followed by pendant cap (5a) to close (See Illustration 4)
5. Make proper electrical connections (black to hot "L", white to neutral "N", ground to "GND") with wire nuts (1b) provided in hardware package
6. Attach mounting plate (1c) to electrical junction box (1a) using junction box screws provided (1e) in hardware package. Secure canopy (2a) to base plate (3d) (See Illustration 1)

Illustration 1

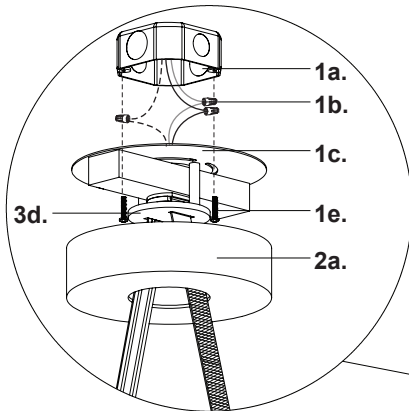

Illustration 2

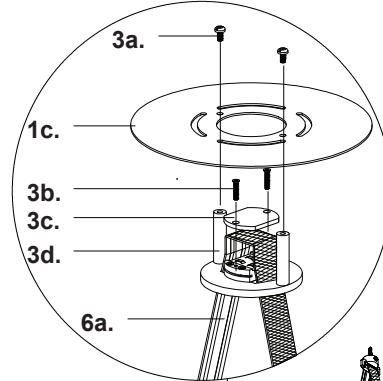

Illustration 3

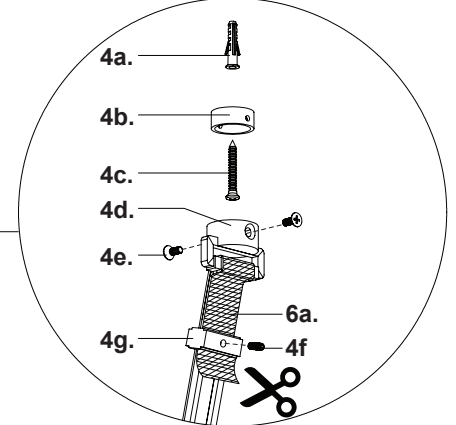
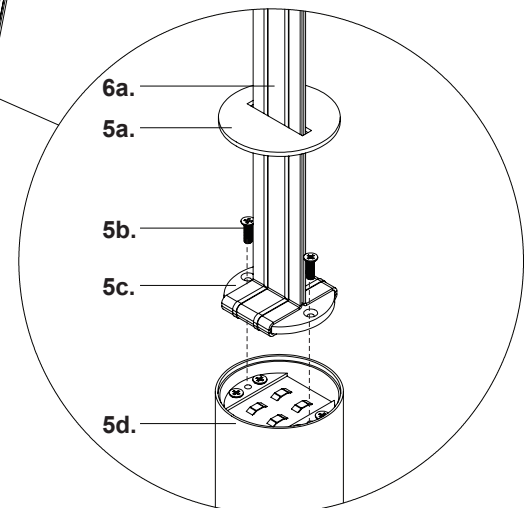

Illustration 4



KUZCO

19054 28th Avenue Surrey, BC Canada V3Z 6M3
T: 604 538 7162 TF: 1-855 85 KUZCO F: 604 538 7196
W: kuzcolighting.com
20240109