

CELL table lamp

Matteo Ugolini design

year 2011

TECHNICAL SHEET - M612B

STRUCTURE "A"

material	steel inox	
colour	glossy white	

SHADE "B"

material	linen	
colour	white	

ELECTRICAL CABLE "C"

material	PVC	
colour	transparent	

ELECTRICAL SYSTEM

socket	E26
source	max 1x18w LED
energy class	from E to A++

PACKAGING

nr. of collis	1
net weight/kg	5
gross weight/kg	6,5
packaging/cm	62x62x65

EMISSION OF LIGHT

one-directional



CERTIFICATION



bulb not provided

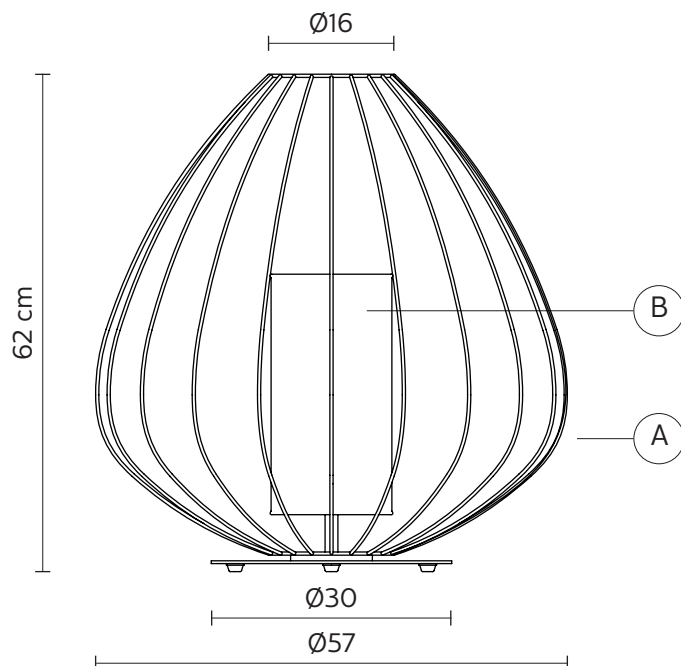

COLLECTION

available also as: suspension (in/outdoor)

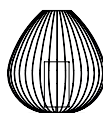

M613B



M614B



M615B



M612-EXT

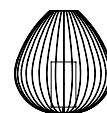

M613-VIE



M615-VIE