

Installation Instructions

For Twilight Sconce 20-4915

B208

Page 1 of 3

CAUTION: FAILURE TO INSTALL THIS FIXTURE PROPERLY MAY RESULT IN SERIOUS PERSONAL INJURY OR DEATH AND PROPERTY DAMAGE. We recommend installation by a licensed electrician.

This product must be installed in accordance with applicable installation code(s), by a person familiar with the construction and operation of the product and the hazards involved.*

Caution: Do not exceed maximum wattage noted on fixture. Use only recommended bulbs with fixture.

Please Note: This fixture is designed to be mounted on a standard wall surface and may not be suitable for all applications. If installing in a non-wood frame application, we recommend consulting a qualified builder or electrician.

After installation extra hardware and accessories are possible due to our kits are used on multiple products and options.

Prepare for installation (Figures 1)

Component Parts

- A Fixture Front
- B Thumb Screw (2)

1. Carefully unpack the fixture from the carton.
2. Remove fixture front (A) by loosening thumb screws (B). *Assemblies are shipped together.* Slide fixture front (B) up to allow it to slip over screws (B). Set aside for later use.

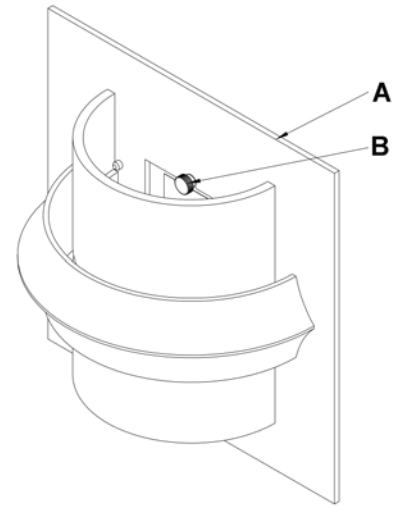

(Figure 1)

To Mount Fixture to Wall (Figures 2)

Component Parts

- C Fixture Back
- D Crossbar
- E Threaded Stud (2)
- F Knurl Ball (2)
- G Ground Screw
- H Cupped Washer

Caution: Be sure power is off at the main breaker box prior to installation.

1. Using two machine screws (not provided), fasten the crossbar (D) to the electric box making sure that fixture mounting holes are level. **Note:** *A new electric box comes with screws. When replacing a fixture, retain the existing screws for use with the new fixture.*
2. Thread studs (E) into the appropriate holes in the crossbar (D). Adjust the studs to proper length to ensure the fixture will fit snugly to the wall.
3. Hold the fixture back (C) close to the wall and using suitable wire connectors, not provided, connect fixture wires to supply (white to white or ribbed and black to black or smooth). Ground the crossbar using the green ground screw (G) and cupped washer (H) to secure a pigtail lead to the bracket.

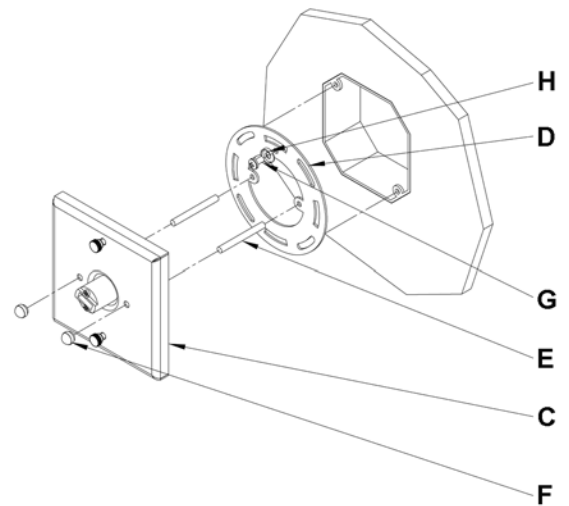

(Figure 2)

Caution: Make sure wire connectors are twisted on securely, and no bare wire is exposed.

(continued)

Installation Instructions

For Twilight Sconce 20-4915

B208

Page 2 of 3

- Slide fixture back (C) over threaded studs (E) and push firmly to wall, making sure that no wires are pinched between fixture back and wall. Fasten with knurl balls (F). Be sure threaded studs (E) are fully seated in the knurl balls (F).
- See instructions following to complete installation.

To Install Glass (Figures 3, 4 & 5)

Component Parts

- A Fixture Front
- I Glass
- J Set Screws (2)
- K Glass Brackets (2)

- Using provided wrench loosen the two set screws (J) installed in the fixture front (A) until they are below the front plate where the glass is to be installed (Figure 4).
- Install glass (I) in fixture front (A) so it rests on the glass brackets (K).
- Using provided wrench install set screws (J) so they are below the back of fixture front (A) (Figure 5).

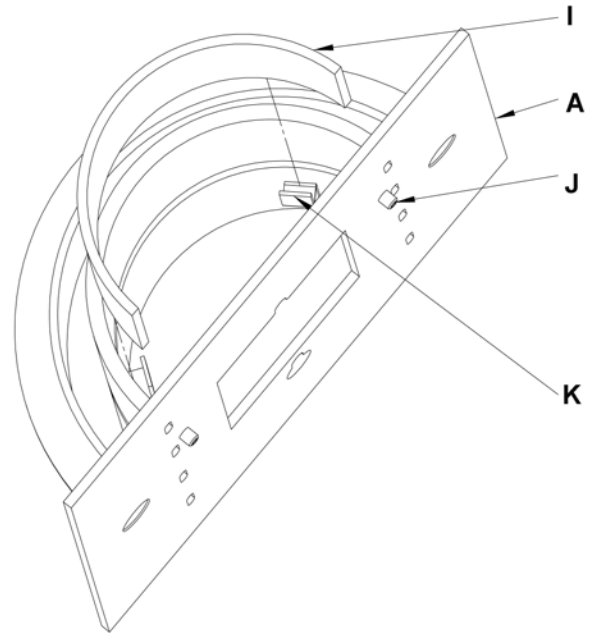

(Figure 3)

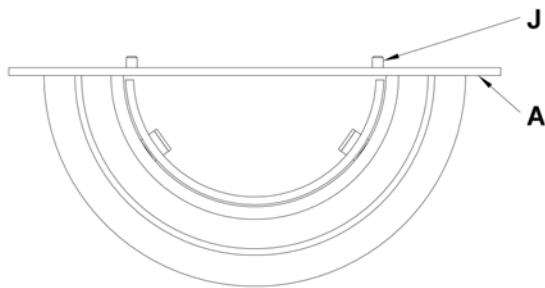

(Figure 4)

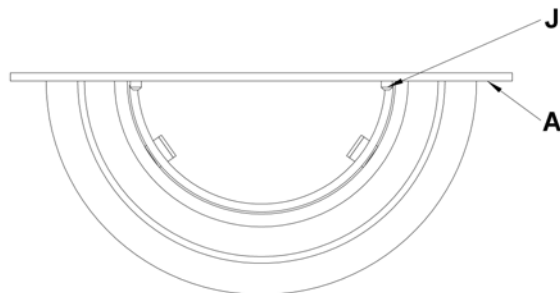

(Figure 5)

(continued)

Installation Instructions

For Twilight Sconce 20-4915

B208

Page 3 of 3

To Install Fixture Front and Bulb (Figure 6)

Component Parts

- A Fixture Front
- B Thumb Screw (2)
- C Fixture Back
- L Bulb (included)

1. Install light bulb (L). *Be careful not to touch bulb with bare hands; oil from the hands will dramatically reduce bulb life.*
2. Slip fixture front (A) over thumb screws (B) aligning slots, lower onto fixture back (C).
3. Tighten thumb screws (B).
4. Restore electricity at the main breaker.

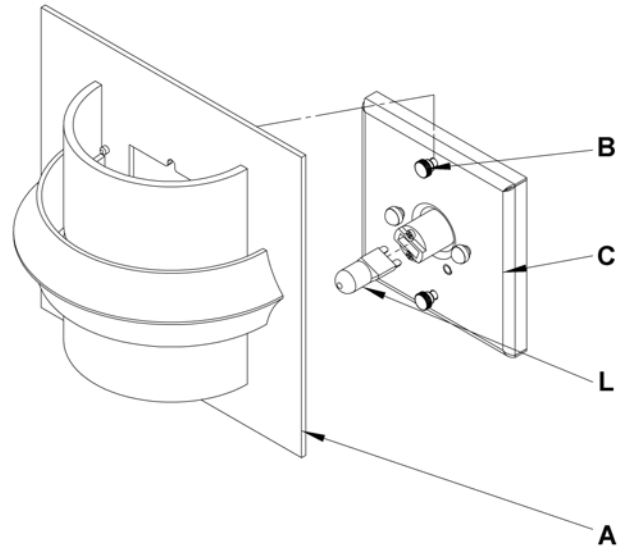

(Figure 6)

If you need further assistance, or find that you are missing any parts, please contact the dealer from which you purchased this product. We hope you enjoy your fixture!

* Hubbardton Forge will not be liable for injury or damage caused by improper installation, lamping or use of this fixture.