

Included Components

- A. Hardware Packet (Not Shown)
- B. Canopy
- C. Face Plate
- D. Cable Stops
 - i. Cap
 - ii. Bushing
 - iii. Bushing
- E. Cover Plate
- F. Cable
- G. Glass Shades
- H. Cable Grippers
 - i. Cap
 - ii. Body

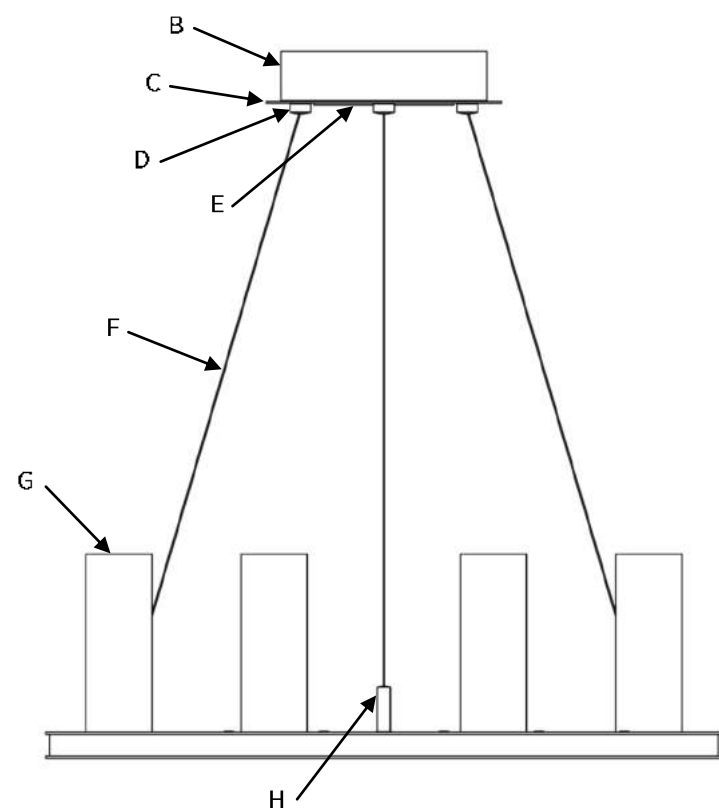

Required Tools

1. Philips screw driver (not provided)
2. Wire cutters/strippers (not provided)
3. Measuring tape (not provided)
4. Level (not provided)

Assembly Instructions

Step 1: Remove Face Plate (C) from Canopy (B) by unscrewing the Cable Stop Caps (Di). The Caps (Di), Face Plate (C), and Bushings (Dii, Diii) will slide down cables (F)

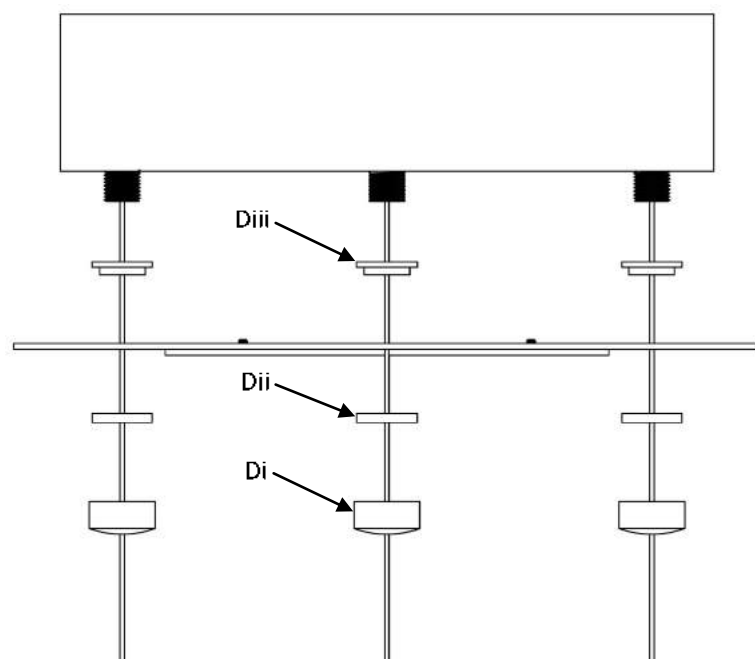

Step 2: Mount Canopy (B) to ceiling using the appropriate Hardware Packet (A) and included instructions.

HARDWARE PACKET T: MOUNTS TO J-BOX

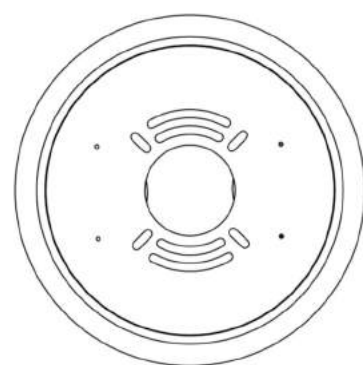

HARDWARE PACKET X: MOUNTS TO J-BOX AND CEILING

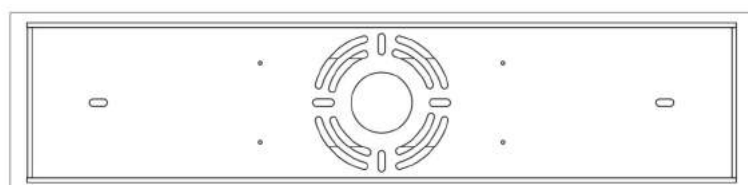

HARDWARE PACKET Z: MOUNTS TO BUILDING STRUCTURE

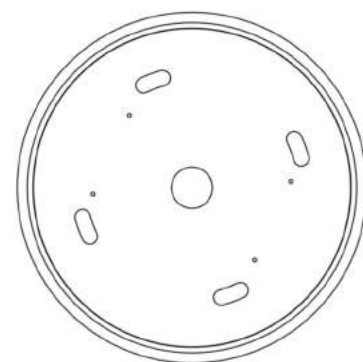

Step 3: Replace Bushings (Dii, Diii), Face Plate (C), and Caps (Di),

Step 4: Cables (F) and Cable Grippers (H) are marked by a numbered tag (e.g. 1-1). Each Cable (F) will be inserted into the Cable Gripper (H) marked with the same number.

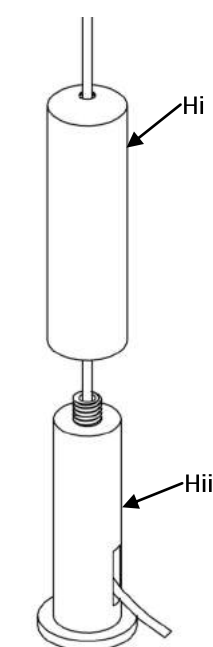

CAUTION: CABLES ARE CONDUCTIVE. DO NOT POWER FIXTURE WHILE CABLES ARE IN CONTACT WITH ANY CONDUCTIVE SURFACE. THIS INCLUDES HAVING THE CABLE PROTRUDE THROUGH THE GRIPPER AND TOUCH THE BODY OF THE LIGHT FIXTURE.

Step 5: After locating the corresponding Cable (F) and Cable gripper (H), unscrew the Cable Gripper Cap (Hi). Thread the Cable (F) through the Cap (Hi) and into the Gripper Body (Hii). Adjust fixture height by pushing or pulling Cable through Gripper Body while depressing threaded plunger at top of Gripper. **THE GLASS SHADES SHOULD NOT BE INSTALLED WHILE HANGING THE FIXTURE.**

Step 6: Use a measuring tape and level to ensure the fixture is hanging at the desired distance from the Canopy. When desired height is attained cut excess Cable flush with Gripper Body. Thread Cable Gripper Cap back onto Body.

Step 7: Remove Cover Plate (E) from Face Plate (C) using the Philips Screw Driver. Make Electrical Connections from the building to the Drivers inside of Canopy using the wire nuts provided. Replace Cover plate.

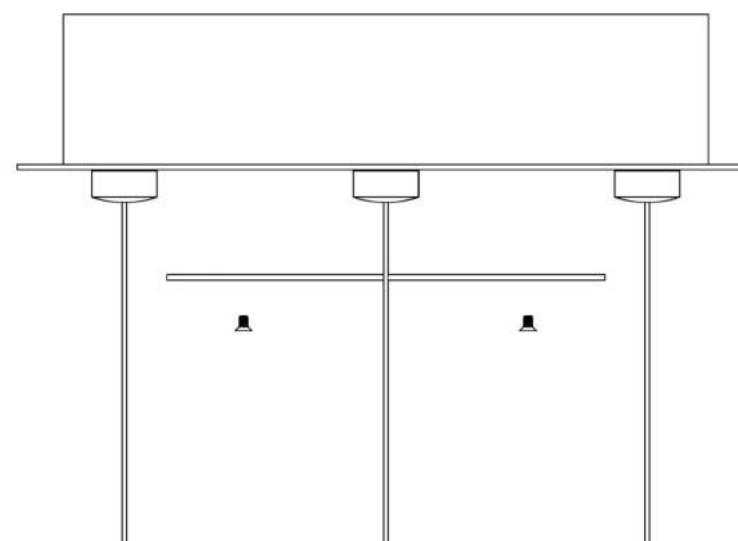

Step 8: Install Glass Shades.

EXAMPLE FIXTURES

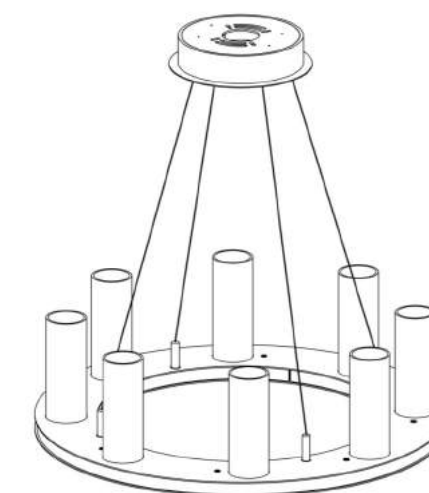

CHB0033-OC

PLB0039-0A

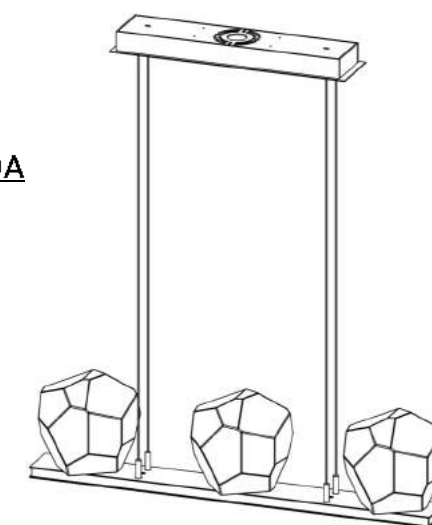

Troubleshooting Guide

- **Fixture does not illuminate**
 - Verify there is power to the fixture.
 - Cables are conductive. Cables cannot be in contact with conductive surfaces, this includes having cables protrude through the gripper and touch the body of the fixture.
 - Conductive cables need to be lined up with corresponding cord grippers. Match cable 1 to gripper 1, 2 to 2, etc.
 - Verify that the red lead from the driver connects to the red conductive cable, which connects to the silver cord gripper.
- **Either down light or up light does not illuminate.**
 - Cables are conductive. Cables cannot be in contact with conductive surfaces, this includes having cables protrude through the gripper and touch the body of the fixture.
 - Conductive cables need to be lined up with corresponding cord grippers. Match cable 1 to gripper 1, 2 to 2, etc.
 - Verify that the red lead from the driver connects to the red conductive cable, which connects to the silver cord gripper.
- **One section of the up light or down light does not illuminate.**
 - Check that LED holder has not come loose during shipment by gently pushing each contact into the LED, while the fixture has power to it. If section lights up, tighten that holder. Caution: over tightening the holder may cause it to crack.

About Hammerton Studio

HAMMERTON STUDIO

In 2013, the Hammerton Studio brand was created to offer artisan-crafted, contemporary design solutions that are both versatile and accessible. Hammerton Studio fixtures add contemporary distinction to entries, great rooms and master suites, yet are cost-effective enough to use throughout any residential or commercial projects. Like all Hammerton fixtures, they are designed and fabricated in Salt Lake City, Utah using domestically sourced materials.

POWERFUL DESIGN

Since 1992, Hammerton has been known for extraordinary decorative lighting that is boldly designed, expertly rendered, perfectly proportioned and exquisitely detailed. Each fixture exudes a design aesthetic that is timeless and enduring, yet remarkably relevant.

UNCOMPROMISING CRAFTSMANSHIP

In addition to their exceptional metalworking and finishing expertise, Hammerton artisans share an aesthetic eye and a sculptural talent that define the difference between ordinary and extraordinary craftsmanship. Every fixture demonstrates its artisan's ability to elevate craft to an art form.

UNIQUE MATERIALS

Hammerton's recent acquisition of the Lightspann brand has added unparalleled strength in all types of artisan glass, including hand-blown, slumped, fused, and lampworked glass. The combination of Hammerton's traditional metalworking and Lightspann glass allows steel, woven mesh, fabric and glass to be combined in a manner which cannot be duplicated.

A REPUTATION REFLECTED BY OUR CLIENTS

Hammerton fixtures are as extraordinary as the clients who purchase them, including Forbes 400 members, Fortune 500 leaders, award-winning entertainers, fashion and interior designers, sports legends, and leading luxury hospitality brands.

Hammerton
217 Wright Brothers Drive
Salt Lake City, UT
84116

801-973-8095
info@hammerton.com
www.hammerton.com

Warranty

ONE YEAR LIMITED WARRANTY

Hammerton, Inc. (Hammerton) warrants the original owner that this product will be free of defects in material or workmanship for the period of one year from the date of original purchase from Hammerton, if (i) the allegedly defective product has not been abused, misused or improperly maintained and or repaired during the warranty period, (ii) the defect is not caused by water damage/flooding, fire, explosion, earthquakes or similar phenomenon, and (iii) the defect is not caused by improper installation (unless installed by Hammerton).

In order to obtain warranty service, the user must first complete a warranty claims form. Hammerton will determine if the product will be inspected on site or returned to Hammerton. If after the inspection Hammerton finds that the product is defective as claimed, Hammerton will, at its option, repair or replace the product free of charge, or Hammerton may in its sole discretion, refund the purchase price. Hammerton warrants any replaced or repaired products for ninety days after shipment or through the end of the original warranty period, whichever is longer. All products or parts that are replaced become the property of Hammerton.

No representative or employee of Hammerton is authorized to make any modification or addition to this limited warranty.

TO THE FULL EXTENT ALLOWED BY LAW, THE FOREGOING WARRANTY AND REMEDIES ARE EXCLUSIVE, AND HAMMERTON EXPRESSLY DISCLAIMS ALL OTHER WARRANTIES, EXPRESSED OR IMPLIED, INCLUDING WITHOUT LIMITATION THE IMPLIED WARRANTIES OF MERCHANTABILITY AND FITNESS FOR A PARTICULAR PURPOSE. TO THE FULL EXTENT ALLOWED BY LAW, HAMMERTON EXCLUDES AND DISCLAIMS LIABILITY, WHETHER BASED IN CONTRACT OR TORT (INCLUDING NEGLIGENCE FOR ANY CONSEQUENTIAL, INDIRECT INCIDENTAL OR SPECIAL DAMAGES OF ANY NATURE ARISING OUT OF THE SALE INSTALLATION, MAINTENANCE, USE OR FAILURE OF THIS PRODUCT, EVEN IF HAMMERTON HAS BEEN ADVISED OF THE POSSIBILITY OF SUCH DAMAGES IN ADVANCE, AND HAMMERTON LIMITS ITS LIABILITY TO REPLACEMENT, REPAIR OR REFUND OF THE PURCHASE PRICE PAID, AT HAMMERTON'S OPTION.)

SOME STATES DO NOT ALLOW LIMITATIONS ON HOW LONG AN IMPLIED WARRANTY LASTS AND/OR DO NOT ALLOW THE EXCLUSION OR LIMITATION OF INCIDENTAL OR CONSEQUENTIAL DAMAGES, SO THE ABOVE LIMITATION ON IMPLIED WARRANTY AND INCIDENTAL OR CONSEQUENTIAL DAMAGES MAY NOT APPLY TO YOU. THIS WARRANTY GIVES YOU SPECIFIC LEGAL RIGHTS YOU MAY HAVE OTHER RIGHTS, WHICH VARY FROM STATE TO STATE

HAMMERTONSTUDIO™

Assembly Instructions For All Cable Suspended Fixtures

CHB0039-0A, CHB0039-0B, CHB0039-0C,
CHB0039-0D, PLB0039-0A, PLB0039-0B,
PLB0039-0C, PLB0039-0D, PLB0039-0E

CHB0033-0C, CHB0033-0D, CHB0033-0E,
PLB0033-0B

Corona Ring Chandelier

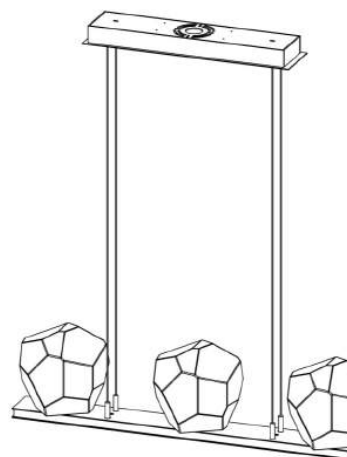
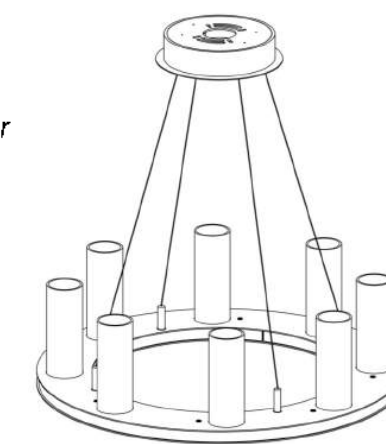

Gem Linear Suspension

WARNING: FAILURE TO INSTALL THIS FIXTURE PROPERLY MAY RESULT IN SERIOUS PERSONAL INJURY OR DEATH AND PROPERTY DAMAGE.

WARNING: MUST USE MANUFACTURER SPECIFIED BULB. USING ANY OTHER TYPE OR WATTAGE BULB MAY CAUSE DAMAGE TO THE FIXTURE AND CREATE A POTENTIAL FIRE HAZARD.

It is recommended that this product be installed by a licensed electrician.

Included Components

- A. 1/4" x 2"L Lags (4)
- B. Washers (4)
- C. Wire Nuts (3)

Required Tools

- 1. Philips Screw Driver (not included)
- 2. Drill (not included)
- 3. 3/16" Drill bit (not included)
- 4. Socket or Wrench (not included)

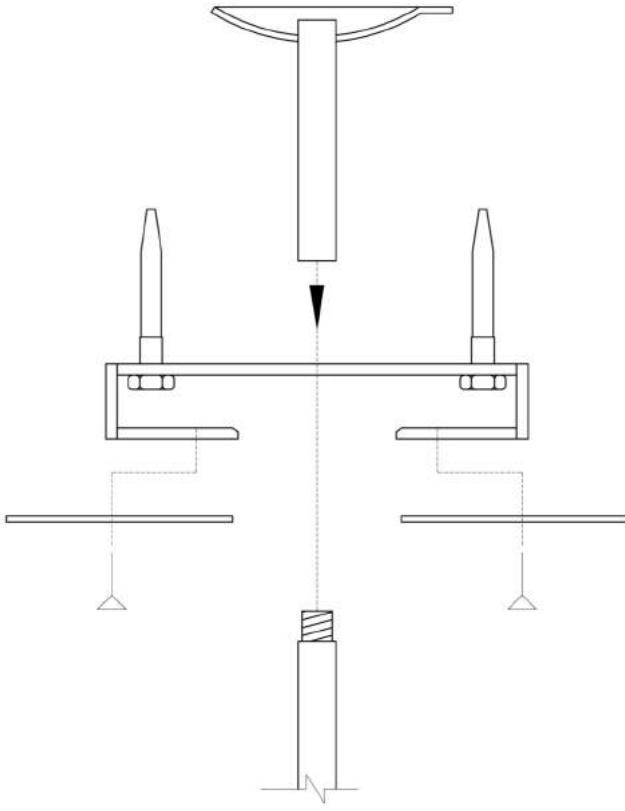

Example: Hang Straight Canopy with $\text{\O}5/8$ " Threaded Stem

Mounting Instructions

Step 1: Mark mounting hole locations using the canopy as a template.

Step 2: Drill pilot holes for the 1/4" lags using the 3/16" drill bit.

Step 3: Install canopy using the provided lags. Canopy must be installed with swivel in place (where applicable).

Step 4: Hang the fixture following the Assembly Instructions. Make wire connections. Install cover plates.

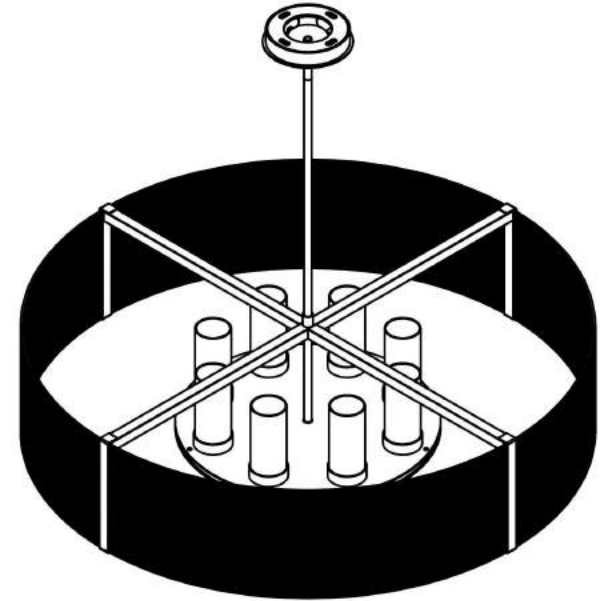

Example: CHB0020-48
Rod Suspended Fixture

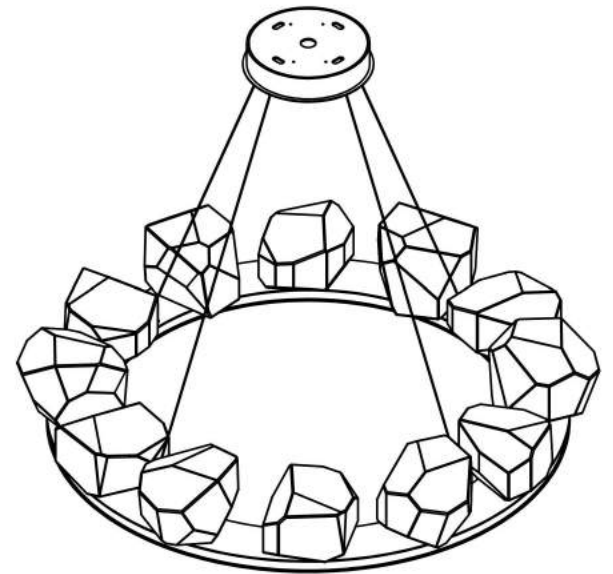

Example: CHB0039-0C
Cable Suspended Fixture

About Hammerton Studio

HAMMERTON STUDIO

In 2013, the Hammerton Studio brand was created to offer artisan-crafted, contemporary design solutions that are both versatile and accessible. Hammerton Studio fixtures add contemporary distinction to entries, great rooms and master suites, yet are cost-effective enough to use throughout any residential or commercial projects. Like all Hammerton fixtures, they are designed and fabricated in Salt Lake City, Utah using domestically sourced materials.

POWERFUL DESIGN

Since 1992, Hammerton has been known for extraordinary decorative lighting that is boldly designed, expertly rendered, perfectly proportioned and exquisitely detailed. Each fixture exudes a design aesthetic that is timeless and enduring, yet remarkably relevant.

UNCOMPROMISING CRAFTSMANSHIP

In addition to their exceptional metalworking and finishing expertise, Hammerton artisans share an aesthetic eye and a sculptural talent that define the difference between ordinary and extraordinary craftsmanship. Every fixture demonstrates its artisan's ability to elevate craft to an art form.

UNIQUE MATERIALS

Hammerton's recent acquisition of the Lightspann brand has added unparalleled strength in all types of artisan glass, including hand-blown, slumped, fused, and lampworked glass. The combination of Hammerton's traditional metalworking and Lightspann glass allows steel, woven mesh, fabric and glass to be combined in a manner which cannot be duplicated

A REPUTATION REFLECTED BY OUR CLIENTS

Hammerton fixtures are as extraordinary as the clients who purchase them, including Forbes 400 members, Fortune 500 leaders, award-winning entertainers, fashion and interior designers, sports legends, and leading luxury hospitality brands.

Hammerton
217 Wright Brothers Drive
Salt Lake City, UT
84116

801-973-8095
info@hammerton.com
www.hammerton.com

Warranty

ONE YEAR LIMITED WARRANTY

Hammerton, Inc. (Hammerton) warrants the original owner that this product will be free of defects in material or workmanship for the period of one year from the date of original purchase from Hammerton, if (i) the allegedly defective product has not been abused, misused or improperly maintained and or repaired during the warranty period, (ii) the defect is not caused by water damage/flooding, fire, explosion, earthquakes or similar phenomenon, and (iii) the defect is not caused by improper installation (unless installed by Hammerton). In order to obtain warranty service, the user must first complete a warranty claims form. Hammerton will determine if the product will be inspected on site or returned to Hammerton. If after the inspection Hammerton finds that the product is defective as claimed, Hammerton will, at its option, repair or replace the product free of charge, or Hammerton may in its sole discretion, refund the purchase price. Hammerton warrants any replaced or repaired products for ninety days after shipment or through the end of the original warranty period, whichever is longer. All products or parts that are replaced become the property of Hammerton. No representative or employee of Hammerton is authorized to make any modification or addition to this limited warranty.

TO THE FULL EXTENT ALLOWED BY LAW, THE FOREGOING WARRANTY AND REMEDIES ARE EXCLUSIVE, AND HAMMERTON EXPRESSLY DISCLAIMS ALL OTHER WARRANTIES, EXPRESSED OR IMPLIED, INCLUDING WITHOUT LIMITATION THE IMPLIED WARRANTIES OF MERCHANTABILITY AND FITNESS FOR A PARTICULAR PURPOSE. TO THE FULL EXTENT ALLOWED BY LAW, HAMMERTON EXCLUDES AND DISCLAIMS LIABILITY, WHETHER BASED IN CONTRACT OR TORT (INCLUDING NEGLIGENCE FOR ANY CONSEQUENTIAL, INDIRECT INCIDENTAL OR SPECIAL DAMAGES OF ANY NATURE ARISING OUT OF THE SALE INSTALLATION, MAINTENANCE, USE OR FAILURE OF THIS PRODUCT, EVEN IF HAMMERTON HAS BEEN ADVISED OF THE POSSIBILITY OF SUCH DAMAGES IN ADVANCE, AND HAMMERTON LIMITS ITS LIABILITY TO REPLACEMENT, REPAIR OR REFUND OF THE PURCHASE PRICE PAID, AT HAMMERTON'S OPTION.) SOME STATES DO NOT ALLOW LIMITATIONS ON HOW LONG AN IMPLIED WARRANTY LASTS AND/OR DO NOT ALLOW THE EXCLUSION OR LIMITATION OF INCIDENTAL OR CONSEQUENTIAL DAMAGES, SO THE ABOVE LIMITATION ON IMPLIED WARRANTY AND INCIDENTAL OR CONSEQUENTIAL DAMAGES MAY NOT APPLY TO YOU. THIS WARRANTY GIVES YOU SPECIFIC LEGAL RIGHTS YOU MAY HAVE OTHER RIGHTS, WHICH VARY FROM STATE TO STATE

HAMMERTONSTUDIO®

Mounting Instructions

Packets S & Z

WARNING: FAILURE TO INSTALL THIS FIXTURE PROPERLY MAY RESULT IN SERIOUS PERSONAL INJURY OR DEATH AND PROPERTY DAMAGE.

It is recommended that this product be installed by a licensed electrician.