



DIMMER MODULE / MULTIPOINT LED

INSTALLATION MANUAL US

(NDM-013407 / BP-DRT250US)

THIS IS A MULTIPOINT LED DIMMER, COMPATIBLE WITH
RETRACTIVE TOGGLE SWITCHES ONLY

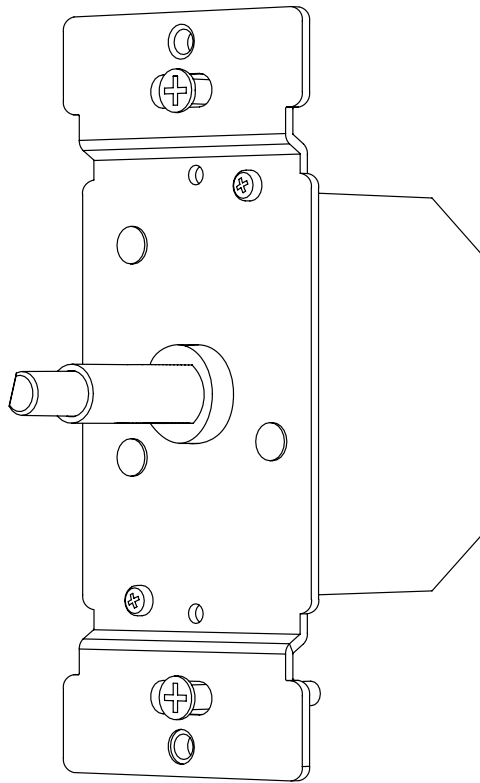

BUSTERANDPUNCH.COM
L0224

EN

IMPORTANT NOTES

PLEASE READ BEFORE INSTALLING.

1. This product must be installed by a qualified professional. Install in accordance with all national and local electrical codes. Turn off the power at the breaker prior to installing this product.
2. This dimmer is not compatible with 3-way or intermediate switches.
3. Use wires rate for at least 75°C & use copper wire only.

CAUTION



EN

TO REDUCE THE RISK OF OVERHEATING AND POSSIBLE DAMAGE TO OTHER EQUIPMENT, DO NOT INSTALL TO CONTROL A RECEPTACLE, A MOTOR-OPERATED APPLIANCE, OR A TRANSFORMER-SUPPLIED APPLIANCE.

FR





ATTENTION: AFIN DE RÉDUIRE LE RISQUE DE SURCHAUFFE ET DE DOMMAGES POTENTIELS À D'AUTRES MATÉRIELS, NE PAS INSTALLER POUR COMMANDER UNE PRISE, UN APPAREIL À MOTEUR OU UN APPAREIL ALIMENTÉ PAR UN TRANSFORMATEUR



WARNING: ELECTRIC SHOCK HAZARD

Hazardous voltage may be present at the dimmer's output despite setting the dimmer to zero brightness level.

ELECTRICAL SPECIFICATIONS

PARAMETER	VALUE
Supply voltage & Frequency	100 - 120V AC 60HZ
Rating	3-250W: When used with dimmable LED lamps. 10-300W: When used with incandescent lamps, halogen lamps and Low Voltage Incandescent Ballasts
Dimming Technology	 Auto Detect Trailing edge dimming type. Leading / Trailing edge dimming mode can be manually set.
Compatible loads for TE Mode	 Dimmable LED lighting with compatible Electronic Transformers
	 LV Halogen Lighting with electronic transformers
Compatible loads for LE Mode	 Incandescent lighting, MV Halogen lamps
	 LV Halogen Lighting with Iron-core transformers
Operating Temperature	32° - 95° F
Operating Humidity	0-90% R.H.

THERMAL OVERLOAD PROTECTION:

This dimmer has a built-in thermal protected circuit. It will automatically switch off if the temperature rises above 131 °F / 55°C and reset when the dimmer cools down to 95 °F / 35°C. If the issue persists, please reduce the load on the dimmer.

SHORT CIRCUIT PROTECTION

Once activated, the dimmer will stop and reset after 5 seconds. If there is still a fault on the circuit, the dimmer will suspend operation until power is disconnected and switch on again. In this case, please contact a qualified professional.

NOTE :

Only Leading Edge mode (LE) is compatible when connecting with IRON-CORE transformers, DO NOT use in Trailing edge (TE) mode. Multiple compatible loads can be used if the total lamp wattage does not exceed the maximum load rating of the dimmer. Some lamps may exhibit unexpected performance characteristics when cold. Dimming performance should improve after the lamp warms up. If the lamp appears unstable, try changing TE or LE mode.

RECYCLING ELECTRICAL PRODUCTS:

Buster and Punch encourages all of its customers to make note of this symbol and avoid putting any waste electrical goods in your domestic waste bin or container. Please ensure you take your waste electrical goods to a suitable facility for disposal.

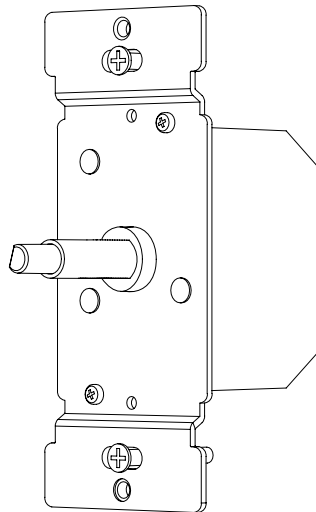

MINIMUM BRIGHTNESS LEVEL SETTING:

How to set the minimum brightness level :

FOLLOW OPERATING STEPS		ACTIONS
1		When the lamp is switched on, press and hold "Push Knob" for 3-5 sec until the lamp appears at half its brightness level.
2		Rotate the knob to program the minimum brightness levels. Press once again to finish programming your dimmer; the lamp will return to maximum brightness level.
You must perform each step within 15 seconds; if not, it will automatically exit the program without saving.		

MODE SETTING

How to manually change the MODE SETTING (Factory default TE auto mode) :
Remove the dimmer knob to view the LED indicator.

The LED indicator show below:
GREEN Light – TE auto mode
GREEN + RED Light - TE mode
RED Light - LE mode

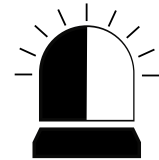

FOLLOW OPERATING STEPS		ACTIONS
1		Pull to remove the dimmer knob to view the LED indicator. Turn the lamp off.
2		Press and hold "Push Knob" for around 3-5 sec until the LED indicator light starts to flash.
3		Turn the knob left or right to select desire mode. Push once to save and exit.
You must perform each step within 15 seconds; if not, it will automatically exit the program without saving.		



IMPORTANT NOTES

PLEASE READ BEFORE INSTALLING.

THIS MODULE MAY BE SUPPLIED WITH THE SECONDARY PUSH BUTTON SWITCH ENGAGED, THIS WILL MEAN THE MODULE WILL NOT POWER ON. BEFORE YOU FIT THE DIMMER NUT & DIMMER KNOB, SWITCH ON THE BREAKER TO THE MODULE TO CONFIRM THE LEDS AT THE BOTTOM OF THE SHAFT COME ON. IF THE LEDS DO NOT COME ON, FOLLOW THE STEPS AT THE END OF THIS INSTRUCTION MANUAL TO DEACTIVATE THE SECONDARY PUSH BUTTON SWITCH.

1 TURN OFF



BEFORE COMMENCING WORK, TURN OFF THE MAIN POWER SUPPLY OR SPECIFIC BREAKER FOR THE DIMMER OR SWITCH AT THE BREAKER BOX. IF YOU ARE NOT SURE WHICH BREAKER CONTROLS THE SWITCH YOU WANT TO REPLACE, THEN TURN OFF THE MAIN POWER SWITCH IN THE BREAKER BOX TO CUT OFF ALL THE POWER TO YOUR HOME.



2 A SINGLE LOCATION DIMMING:

HOW TO DIM THE DIMMER SWITCH:

Push to turn lights on / off. Turn knob clockwise to increase brightness. Turn knob anti-clockwise to decrease brightness.

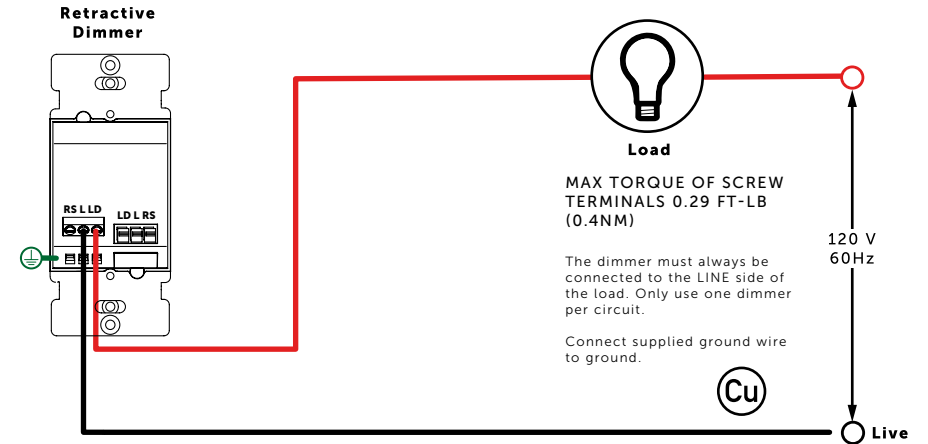

2 B MULTIPLE LOCATION DIMMING:

HOW TO DIM FROM MULTIPLE LOCATIONS SWITCH :

Press retractive toggles to switch lights ON/OFF. Press and hold toggle to increase brightness, release and press and hold to decrease brightness.

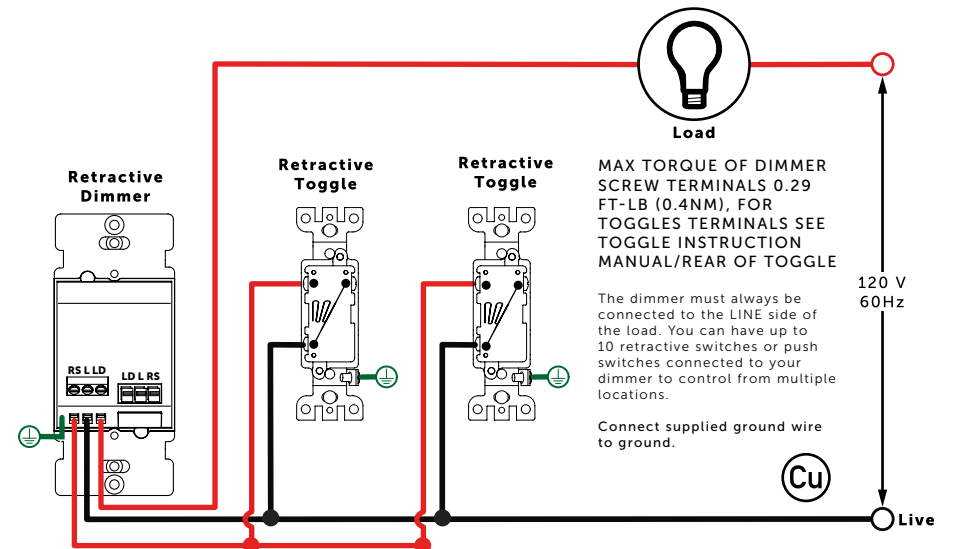

2C EXISTING 3-WAY WIRING DIAGRAM

Live to Toggle Switch/ Dimmer to Load.

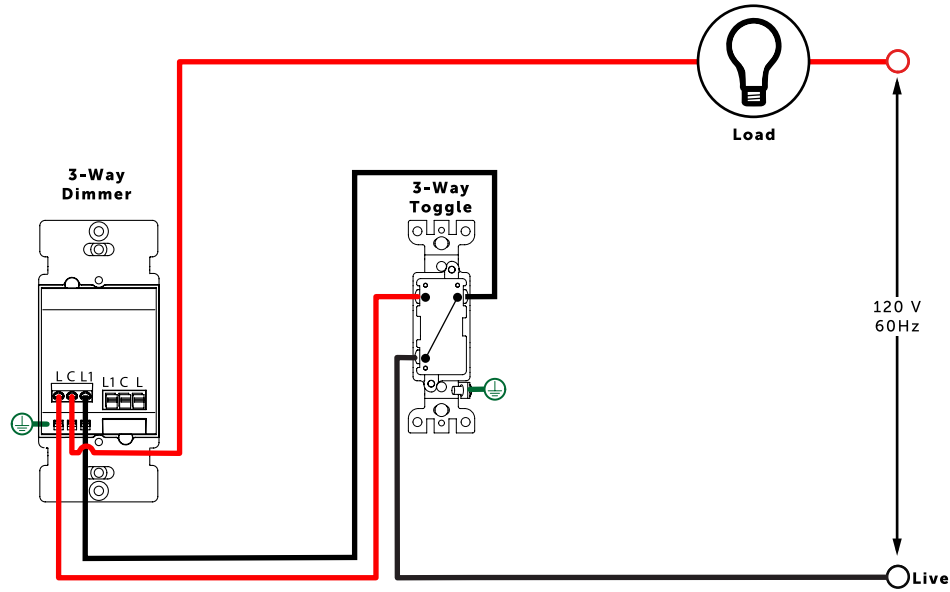

NEW RETRACTIVE WIRING DIAGRAM

Utilize existing wiring, re-purpose **Red Traveler** — wire to Live —, make appropriate connection in the J-box.

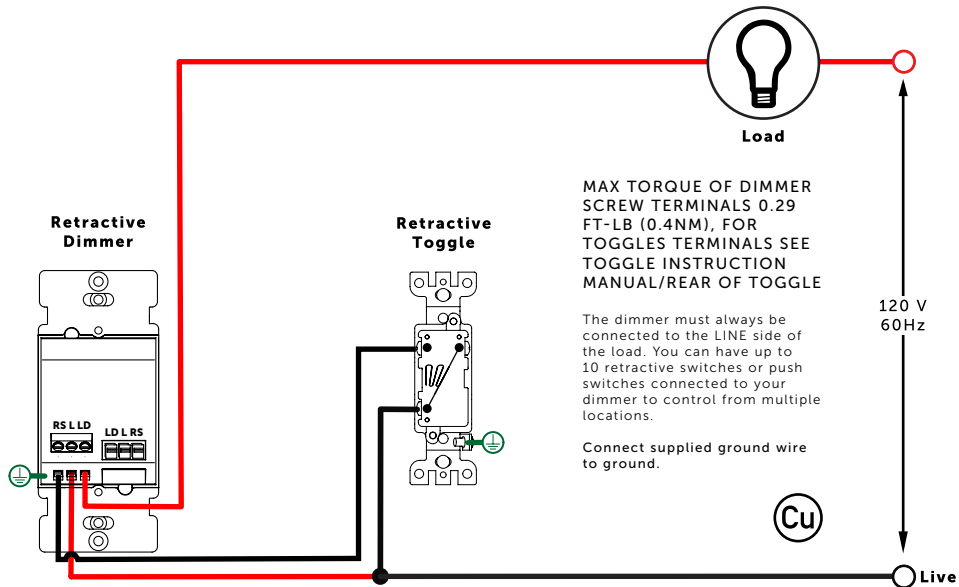

2D EXISTING 3-WAY WIRING DIAGRAM

Live to Dimmer / Toggle Switch to Load.

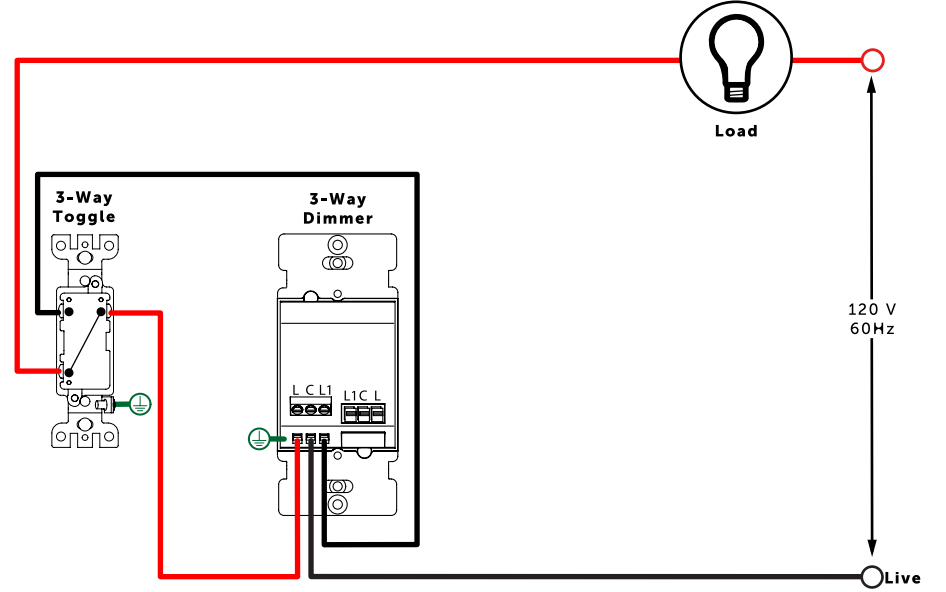

NEW RETRACTIVE WIRING DIAGRAM

Utilize existing wiring, re-purpose **Red Traveler** — wire to Load —, additional **Purple** — wire required to connect Live to Retractive Toggle Switch, make appropriate connections in the J-box's.

*If Additional **Purple** — Wire not possible follow 3C Wiring diagram by switching the positions of the Retractive Dimmer and Retractive Toggle Switch.

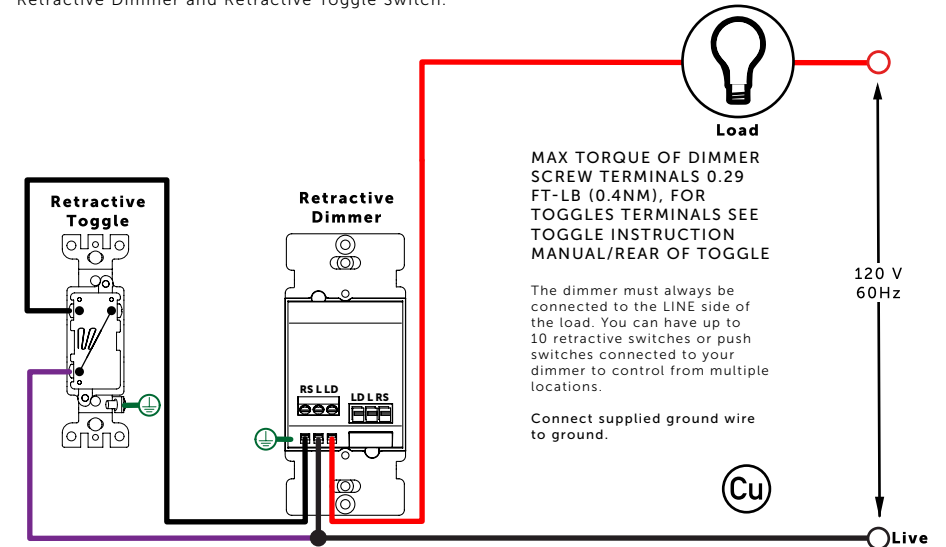

2 E EXISTING 4-WAY WIRING DIAGRAM

Live to Toggle Switch / Intermediate Toggle Switch / Dimmer to Load.

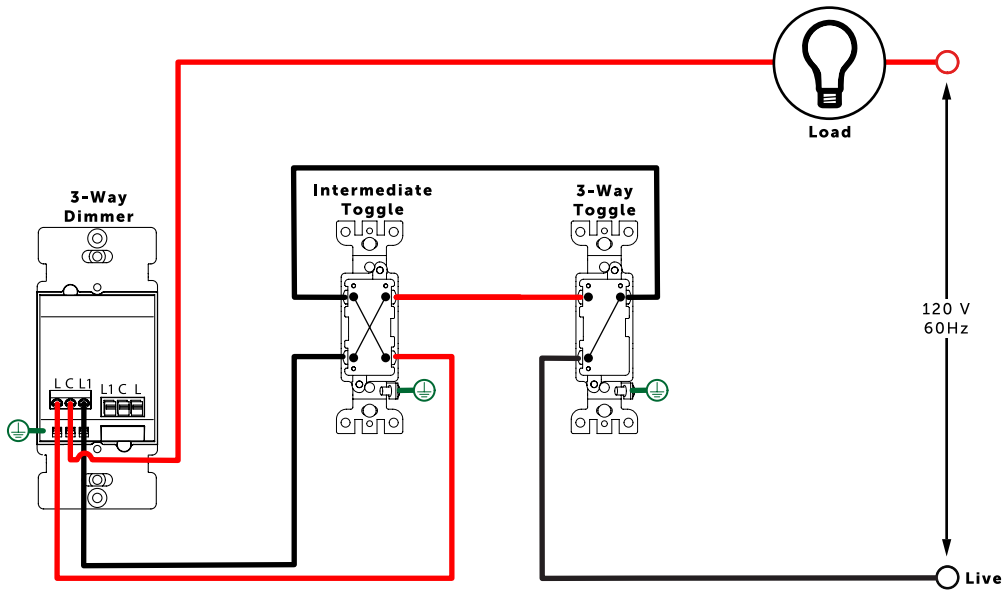

NEW RETRACTIVE WIRING DIAGRAM

Utilize existing wiring, re-purpose Red Traveler — wire to Live —, additional Purple — wires required to connect Live & Signal wires to Retractive Toggle Switches, make appropriate connections in the J-box's

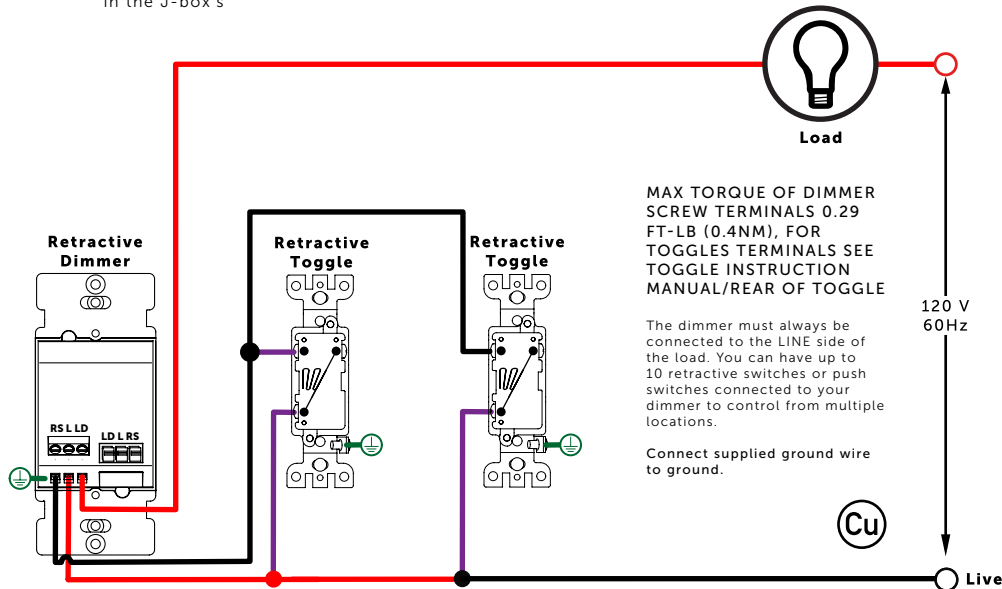

2 F EXISTING 4-WAY WIRING DIAGRAM

Live to Dimmer / Intermediate Toggle Switch / Toggle Switch to Load.

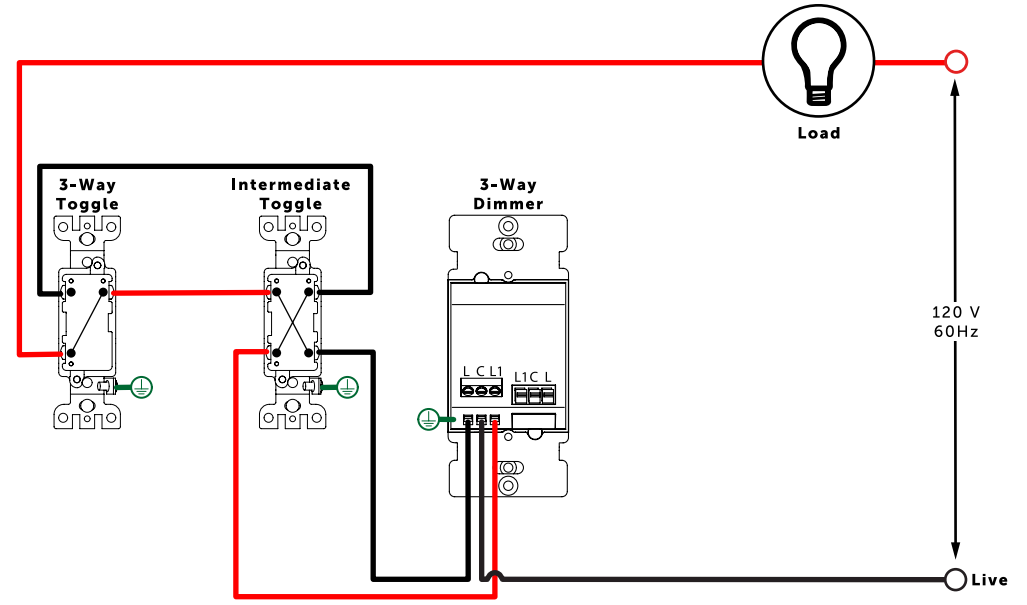

NEW RETRACTIVE WIRING DIAGRAM

Utilize existing wiring, re-purpose Red Traveler — wire to Live —, additional Cyan — wire required to connect Load to Retractive Dimmer, additional Purple — wires required to connect Live & Signal wires to Retractive Toggle Switches, make appropriate connections in the J-box's

*If Additional Cyan — Wire not possible follow 3E Wiring diagram by switching the positions of the Retractive Dimmer and Retractive Toggle Switches.

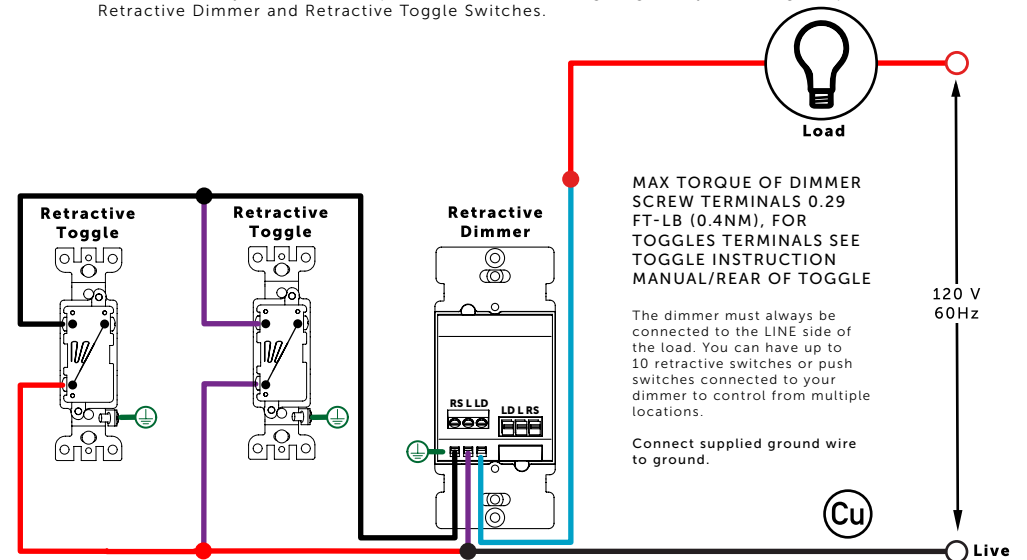

3 MOUNT MODULE INTO WALL BOX / PLATE USING SCREWS PROVIDED.

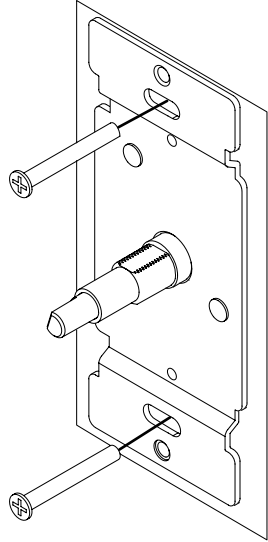

4 PLACE INFILL PLATE OVER THE DIMMER SHAFT
PLACE COVER PLATE OVER THE INFILL PLATE & TIGHTEN SCREWS PROVIDED FINGER TIGHT.

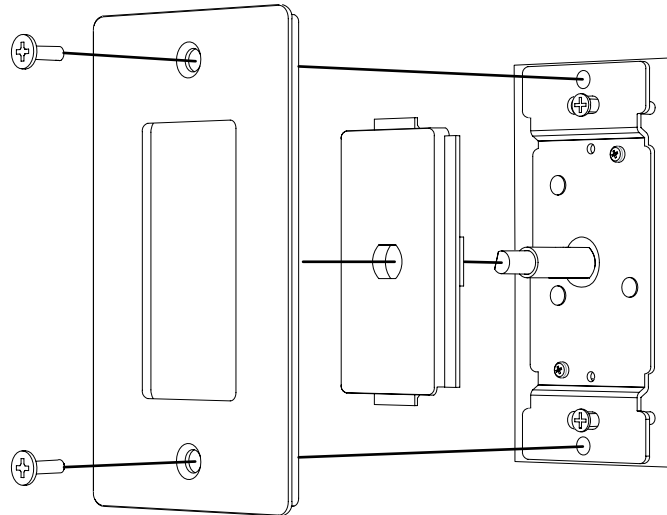

5 SCREW NUTS (2 PARTS; PLASTIC THEN METAL NUT) IN PLACE, BY HAND. ALIGN FLATS ON DIMMER
KNOB & DIMMER SHAFT, AND PRESS FIT BY HAND.

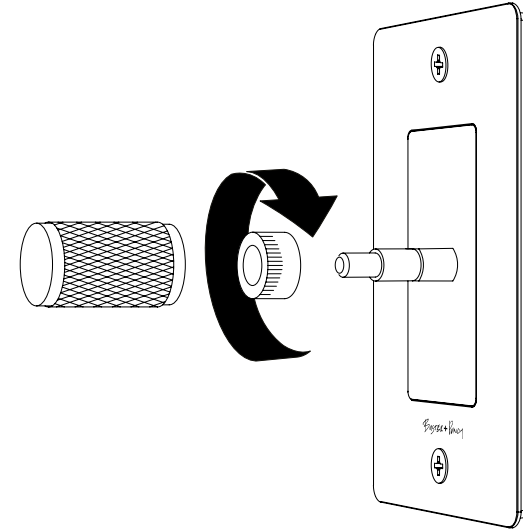

NOTE:
When tightening threaded parts be careful not to cross thread. We recommend pushing and rotating the part anticlockwise until you feel a click, then tighten clockwise finger tight.

6 FIT COIN CAPS USING TOOL PROVIDED, FINGER TIGHT, BE SURE NOT TO OVER-TIGHTEN

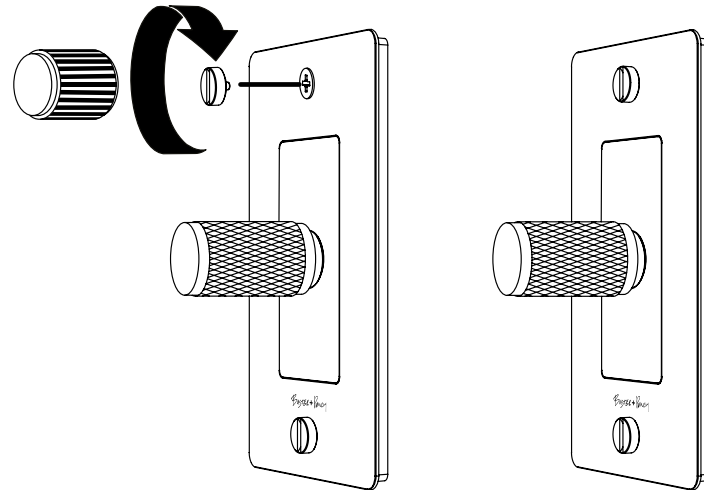

NOTE:
When tightening threaded parts be careful not to cross thread. We recommend pushing and rotating the part anticlockwise until you feel a click, then tighten clockwise finger tight.



7 TURN POWER BACK ON.



SECONDARY PUSH BUTTON SWITCH OPERATION

ACTIVATING THESE SECONDARY PUSH BUTTON SWITCH WILL TURN OFF POWER TO THE CIRCUIT.

STEPS:

1. Make sure bulbs are off.
2. Remove Dimmer Knob & Dimmer Nut.
3. Confirm light at the bottom of the dimmer shaft is on (red / green or both).
4. Depress the shaft & rotate clockwise approximately 30 degrees, the light at the bottom of the shaft will turn off.
5. The circuit is now turned off.
6. To turn circuit back on depress the shaft & rotate anti-clockwise approximately 30 degrees, the light will turn back on.
7. Refit the dimmer nut & knob.

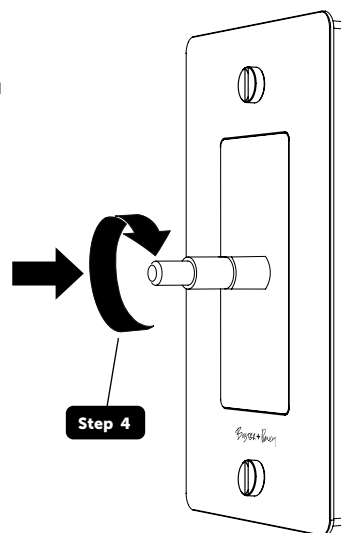

[end. ORDINARY]