

TECH LIGHTING®

SUSPENSION

GENERAL PRODUCT INFORMATION:  This product is suitable for damp locations.

This product may be dimmed with a low-voltage electronic dimmer or triac dimmers.

This instruction shows a typical installation.

CAUTION - RISK OF FIRE
 This product must be installed in accordance with the applicable installation code by a person familiar with the construction and operation of the product and the hazards involved.
 Use minimum 90°C supply conductors.

NOTE: Due to the complexity of this fixture, assistance will be needed for installation.

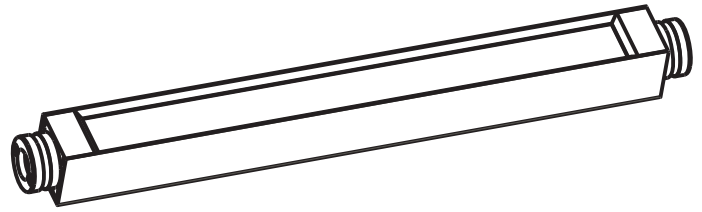

Prepare for installation

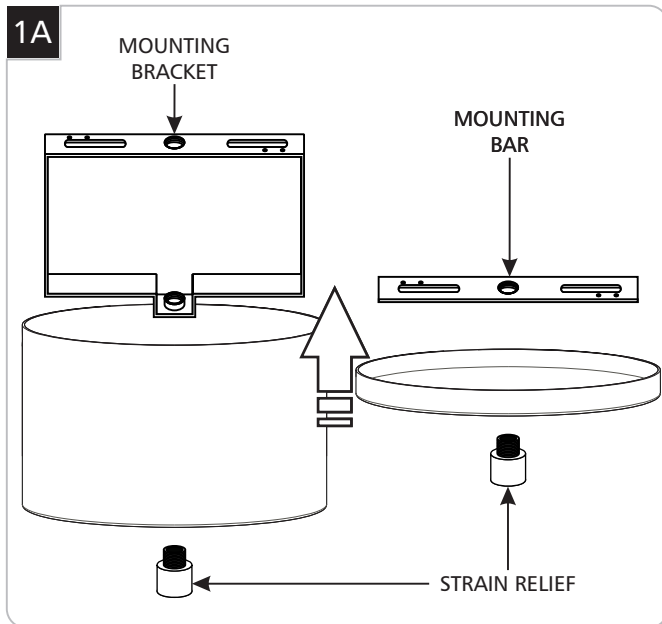

- 1 Unscrew the strain relief from the canopy to remove the mounting bar/bracket (depending on your canopy type).

NOTE: For surface mount canopies, continue to step 2A. For remote canopies skip ahead to step 3A.

Install Surface Mount Canopy

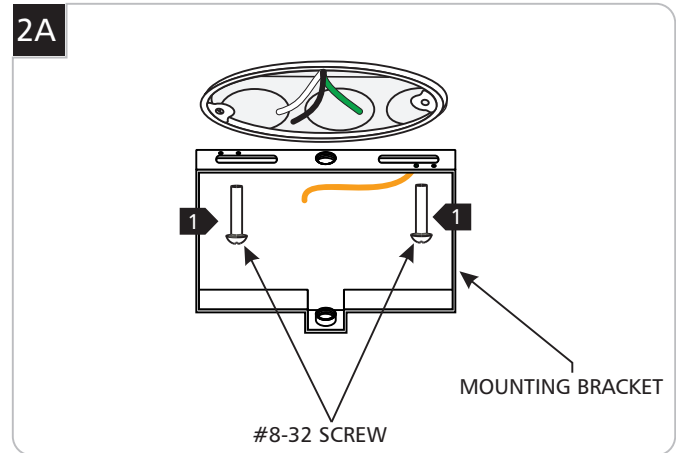

- 1 Secure the mounting bracket to the junction box with #8-32 screws.

2B

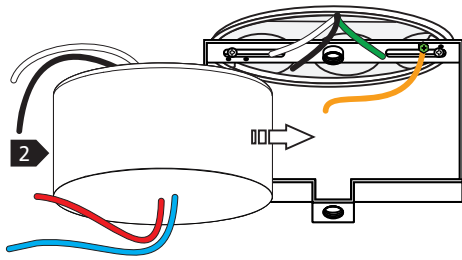

2 Slide the transformer into the mounting bracket.

2C

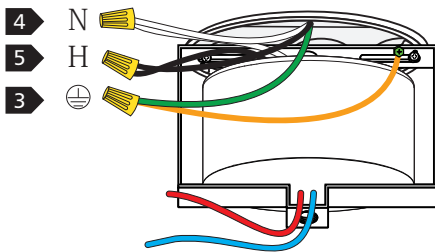

- 3 Connect the mounting plate to a suitable ground in accordance with local electrical codes.
- 4 Connect the white wire to the neutral power line wire with a wire nut.
- 5 Connect the black wire to the hot power line wire with a wire nut.

2D

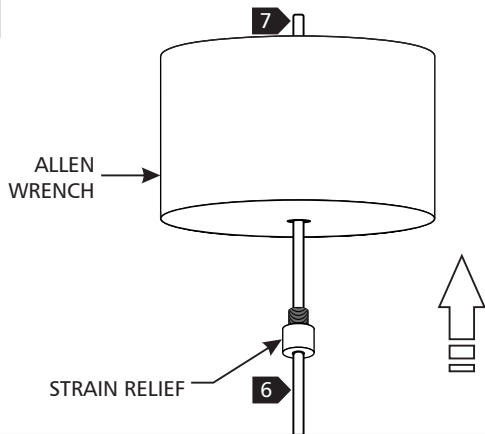

- 6 Feed the power feed wires through the strain relief and canopy.
- 7 Cut the fixture wires to the approximate length desired, leaving a little extra for adjustment.

2E

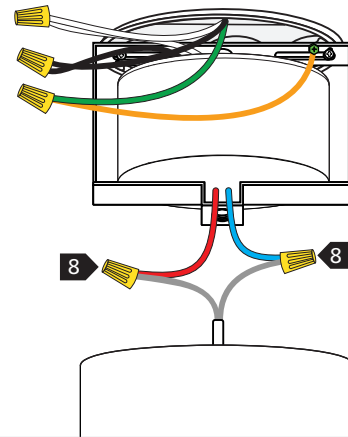

8 Connect the transformer wires to the fixture wires.

2F

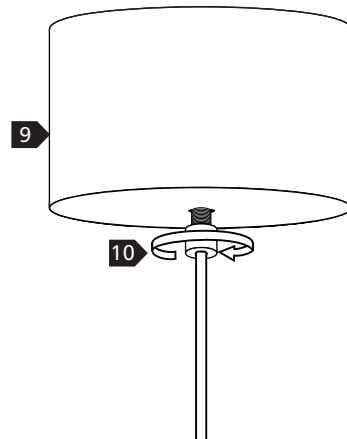

- 9 Lift the canopy up over the mounting bracket and neatly tuck all the wire connections into the canopy
- 10 Secure the canopy in place with the strain relief by screwing it into the mounting bracket.

2G

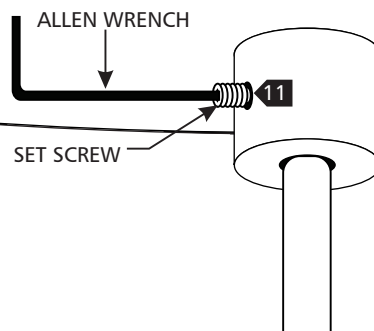

11 Make any fine adjustments necessary then secure the fixture wires in place with the set screw and allen wrench.

Install Remote Driver and Canopy

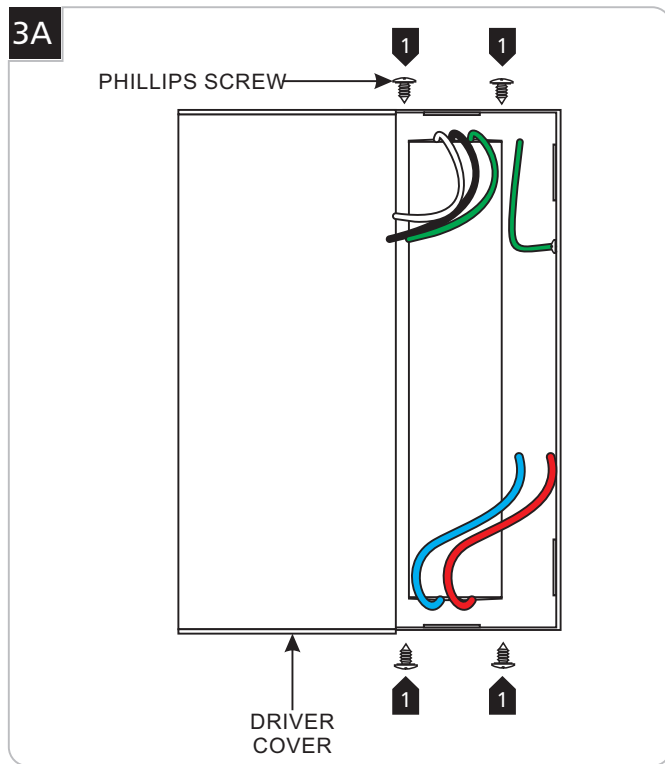

NOTE: In order to use small gage wires from the transformer to the electrical box, it is recommended to install the remote transformer near (if possible) the electrical box. See "Low Voltage Wire Size Table" below.

NOTE: Other wire sizes that comply with electrical code can be used, but may result in an increased voltage drop and reduced lamp intensity.

- 1 Remove the four Phillips screws to remove the driver cover.

NOTE: The THHN wire sizes are for 3% or less drop in voltage based on 100 watt loads. Lengths are the distance from the transformer to the system power feed connector.

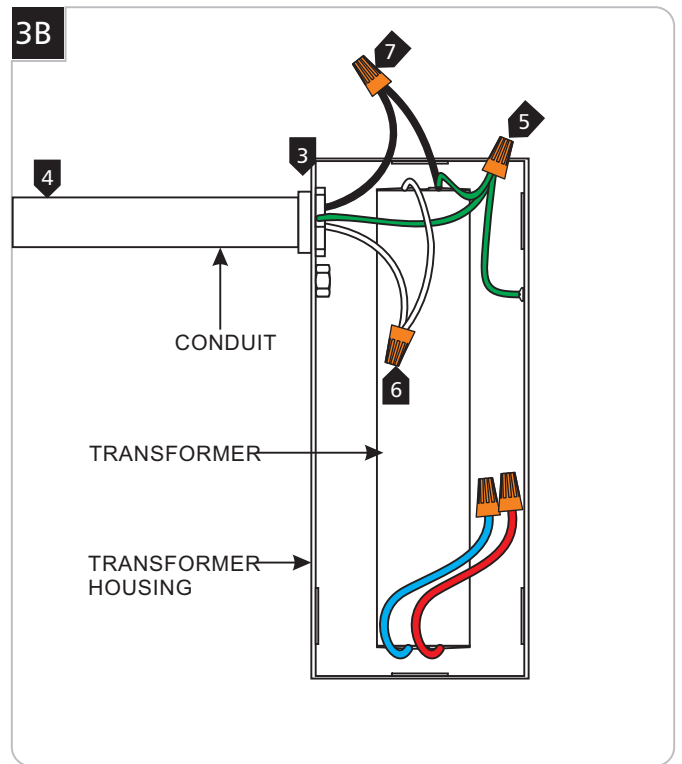

- 2 Secure the driver housing in place (hardware not included).
- 3 Install a conduit and power line wires from the panel to the remote driver.
- 4 **Do not** connect the power line wires to the panel at this time.
- 5 Make sure the driver housing is grounded in accordance with local electrical codes.
- 6 Connect the driver white wire to the neutral power line wire with a wire nut.
- 7 Connect the driver black wire to the hot power line wire with a wire nut.

LOW VOLTAGE WIRE SIZE TABLE

TRANSFORMER WATTAGE	WIRE SIZE FOR 5 FT	WIRE SIZE FOR 6-10 FT	WIRE SIZE FOR 11-15 FT	WIRE SIZE FOR 16-25 FT	WIRE SIZE FOR 26-40 FT	WIRE SIZE FOR 41-60 FT	WIRE SIZE FOR 61-90 FT
100 WATT	#20 GA	#18 GA	#16GA	#14 GA	#14 GA	#12 GA	#10 GA

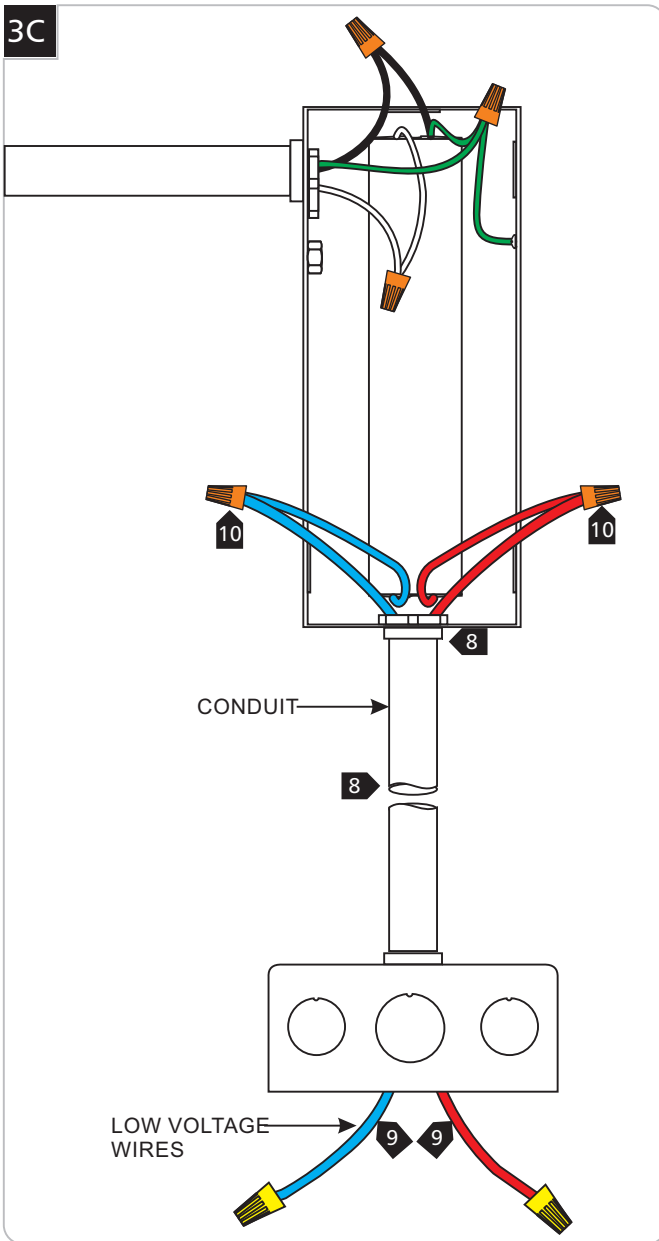

- 8 Install a conduit from the driver to the electrical box.
- 9 Install the low voltage wires from the driver to the electrical power feed box.
- 10 Connect the blue and red driver wires to each low voltage wire with a wire nut.

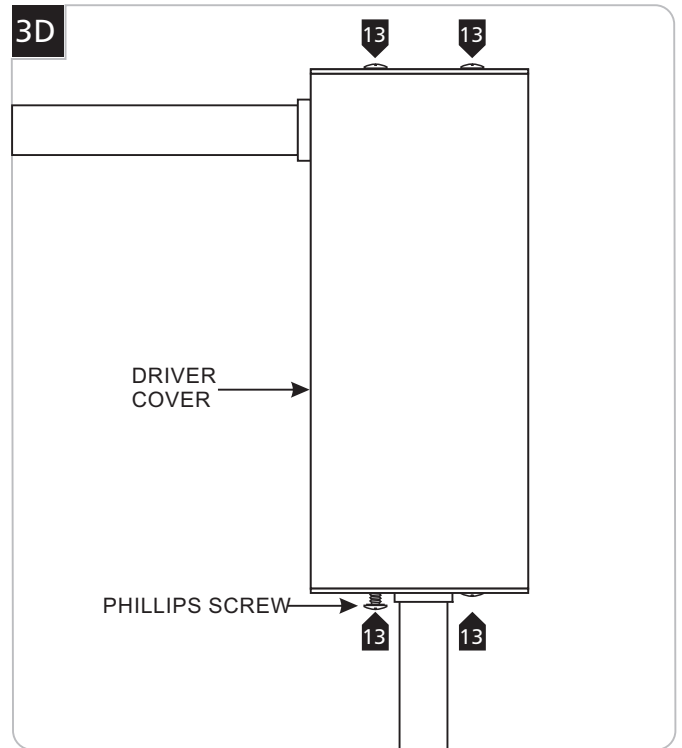

- 11 Connect the 120 volt power line wires at the panel.
- 12 After installing the entire system, operate the system for five minutes. On the low voltage side, all electrical connection points should be no more than warm to the touch. If a connection is hot to the touch, retighten the connection and check to ensure that the temperature decreases.
- 13 Replace the driver cover and tighten the four Phillips screws.

LOW VOLTAGE WIRE SIZE TABLE

TRANSFORMER WATTAGE	WIRE SIZE FOR 5 FT	WIRE SIZE FOR 6-10 FT	WIRE SIZE FOR 11-15 FT	WIRE SIZE FOR 16-25 FT	WIRE SIZE FOR 26-40 FT	WIRE SIZE FOR 41-60 FT	WIRE SIZE FOR 61-90 FT
100 WATT	#20 GA	#18 GA	#16GA	#14 GA	#14 GA	#12 GA	#10 GA

3E

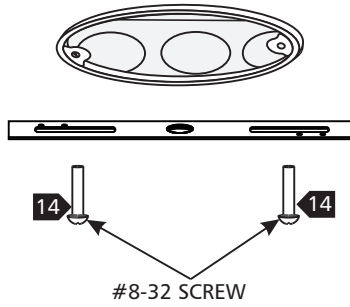

14 Secure the mounting plate to the junction box with #8-32 screws.

3F

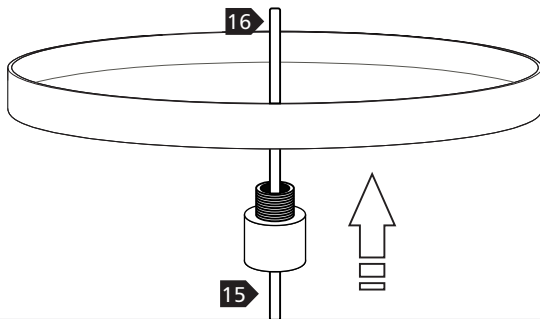

15 Feed the power feed wires through the strain relief and canopy.

16 Cut the fixture wires to the approximate length desired, leaving a little extra for adjustment.

3G

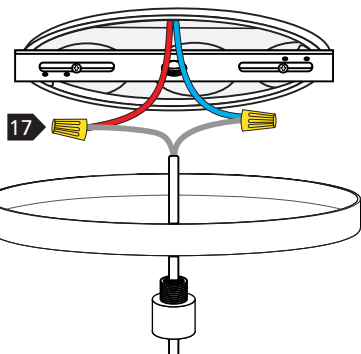

17 Connect the transformer wires to the fixture wires.

3H

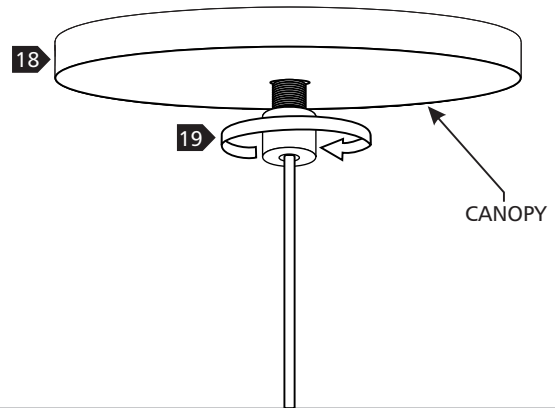

18 Lift the canopy up over the mounting bracket and neatly tuck all the wire connections into the canopy

19 Secure the canopy in place with the strain relief by screwing it into the mounting bracket.

3I

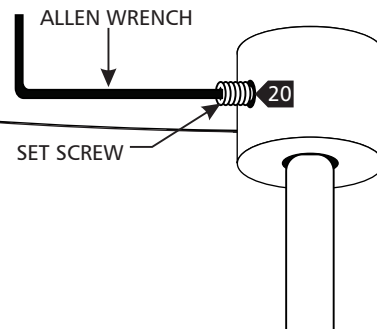

20 Make any fine adjustments necessary then secure the fixture wires in place with the set screw and allen wrench.

Install Ceiling Supports

NOTE: The system requires that the first 8 feet needs two supports (not including the power feed) for every additional 8 feet add an additional support.

4A

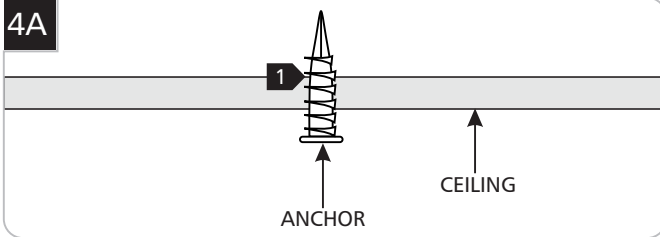

1 Tap the anchor at the marked point into the wall up to the threaded portion with a hammer.

4B

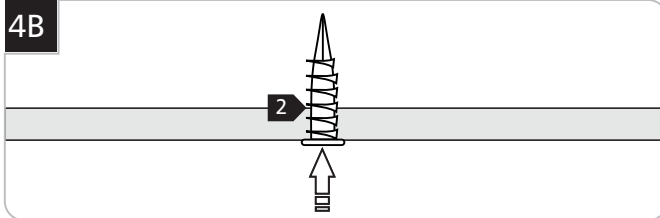

2 Screw the anchor in the rest of the way with a Phillips screwdriver.

4C

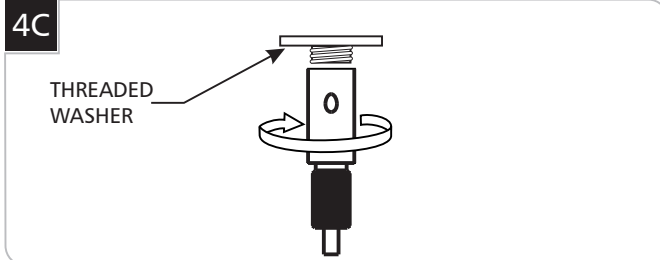

3 Unscrew the threaded washer to separate it from the cable post.

4D

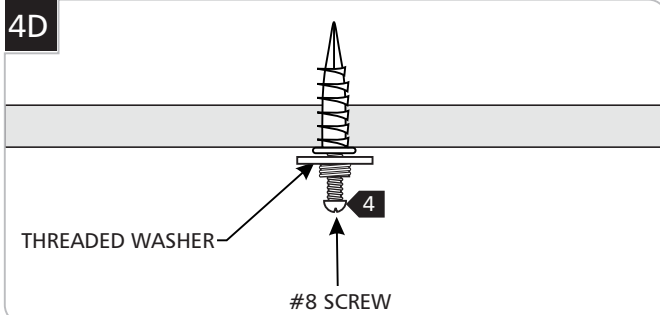

4 Screw the threaded washer onto the anchor with the long #8 screw.

4E

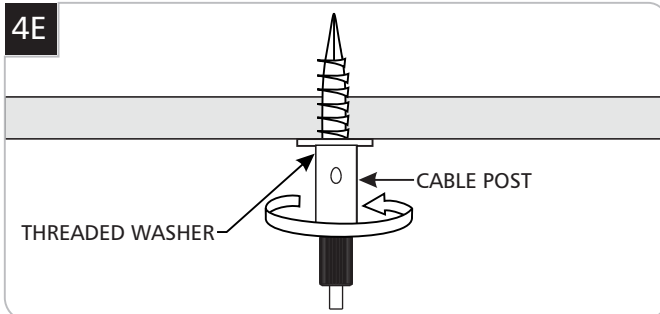

5 Tightly screw the cable post back onto the threaded washer.

4F

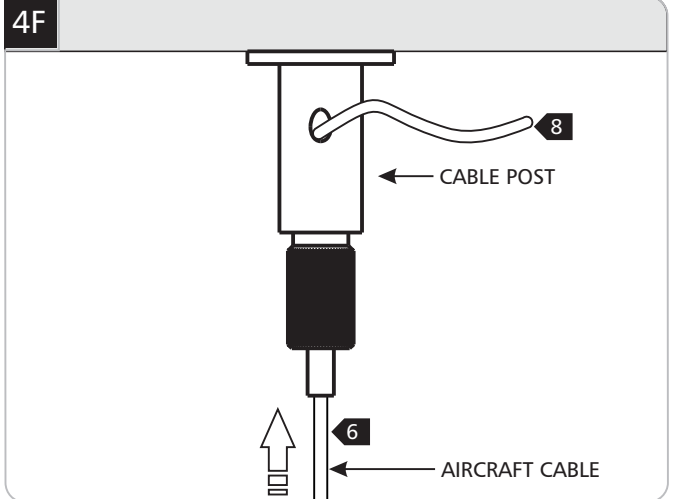

6 Feed the aircraft cable into the cable post.

7 Adjust the cable to the desired height and level the fixture.

8 Cut the excess cable once the fixture has been leveled.

9 Repeat Steps 4A - 4F as needed.

(Optional: Install Wall Supports)

4G

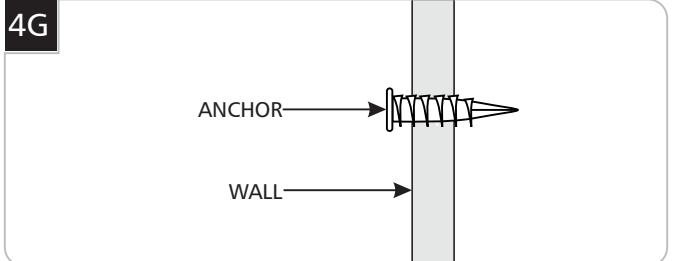

10 Tap the anchor at the marked point into the wall up to the threaded portion with a hammer.

4H

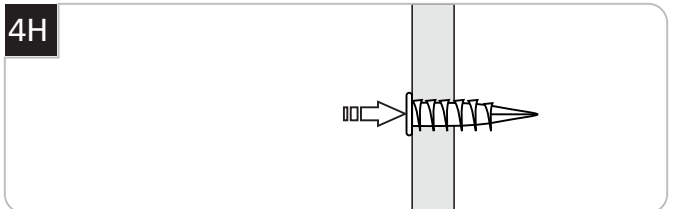

11 Screw the anchor in the rest of the way with a Phillips screwdriver.

4I

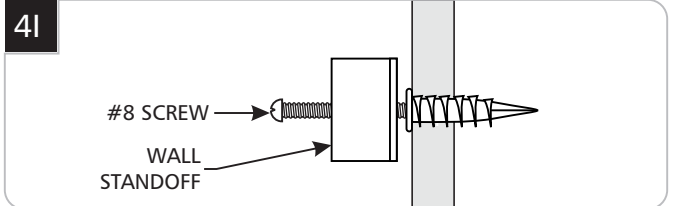

12 Screw the wall standoff onto the anchor with the long #8 screw.

Assemble the fixture

NOTE: Due to the nature of this system there is not necessarily one best way to assemble the fixture. This is a depiction of the most common procedure. These principals can be extrapolated from to create more complex configurations.

NOTE: Due to the potential complexity of the system being installed, you may require assistance during the install to help support the fixture while making connections.

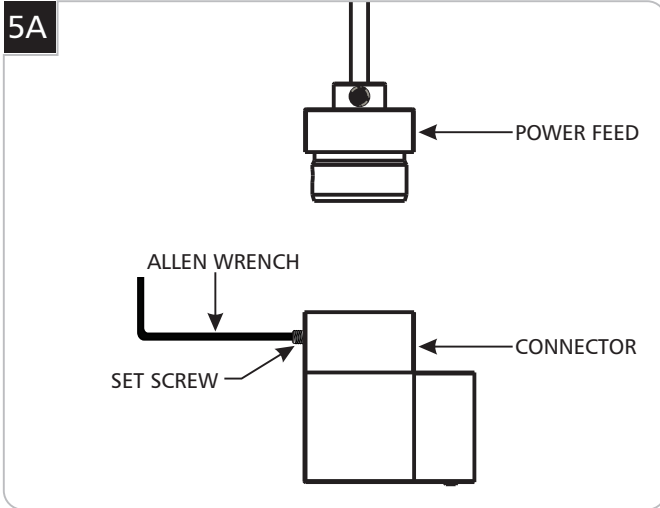

1 Loosen the set screw on the connector with the allen wrench

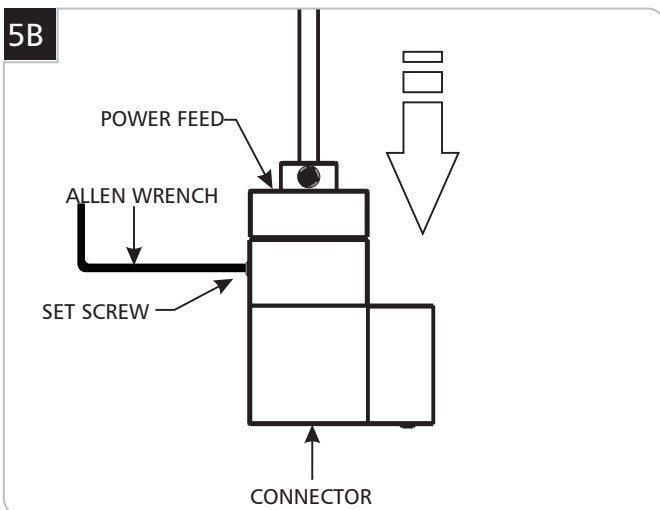

2 Insert the power feed into the connector and secure it in place with the set screw

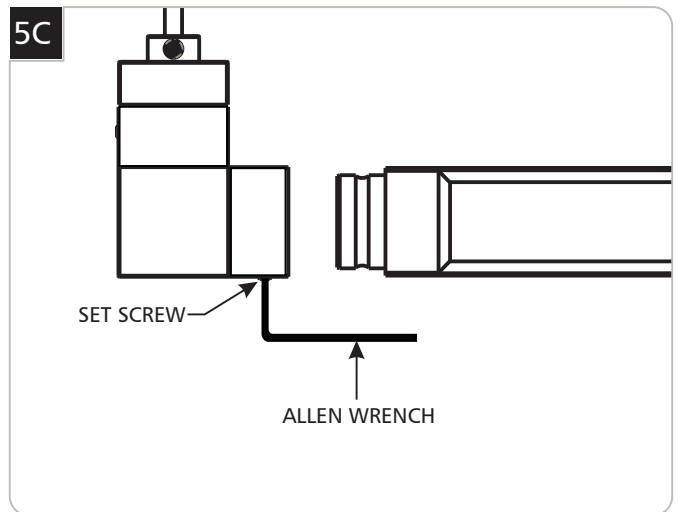

3 Loosen the set screw on the connector with the allen wrench

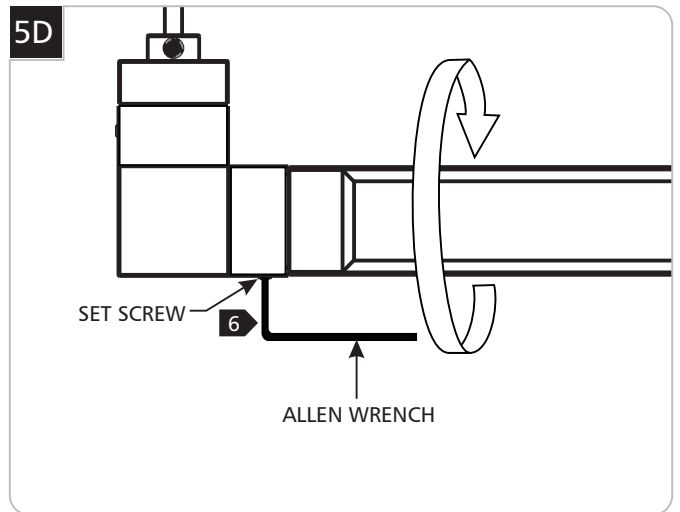

4 Insert the light bar into the connector

5 Rotate the light bar to the desired angle.

6 Tighten the set screw with the allen wrench to secure the light bar in place.

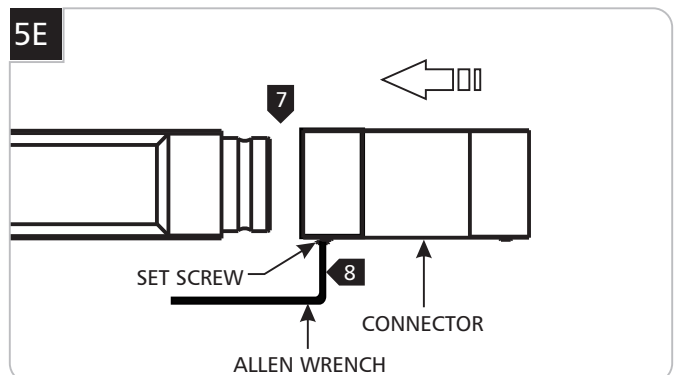

7 Slide the intermediate connector of your choice onto the light bar.

8 Tighten the set screw with the allen wrench to secure the connector to the light bar.

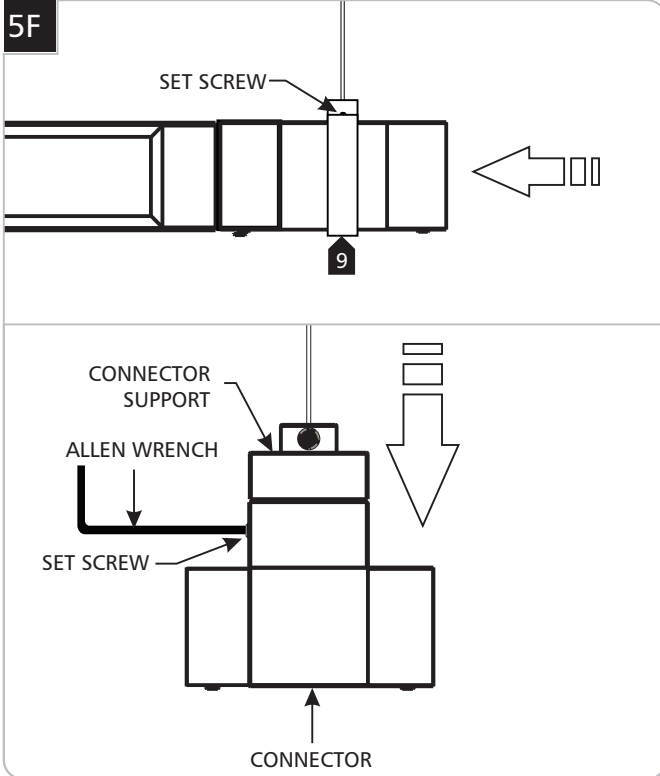

- 9 Loosen the set screw on the bracket or connector support with the allen wrench
- 10 Slide bracket from the previously installed supports over the connector or insert the connector support into the connector.
- 11 Tighten the set screw on the support bracket or connector support to secure it in place.

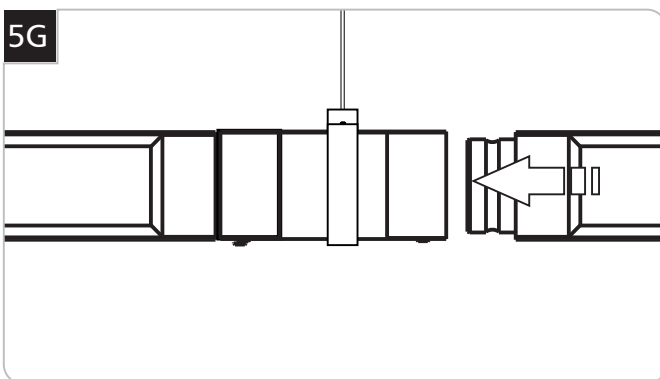

- 12 Insert the next section of light bar as done previously.
- 13 Continue this process until the configuration is complete.

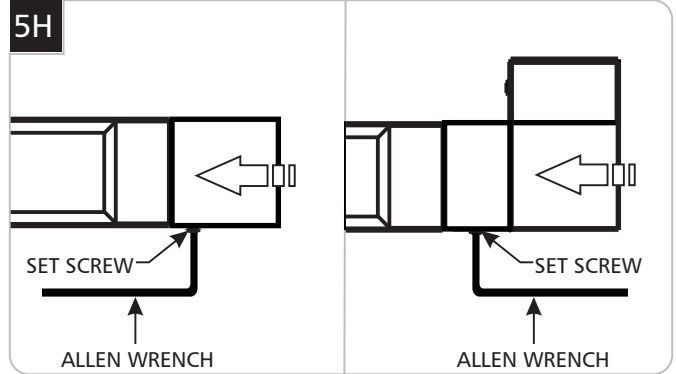

- 14 For open ended systems, slide the end cap or connector onto the light bar.
- 15 Tighten the set screw with the allen wrench to secure the end cap or connector to the light bar.

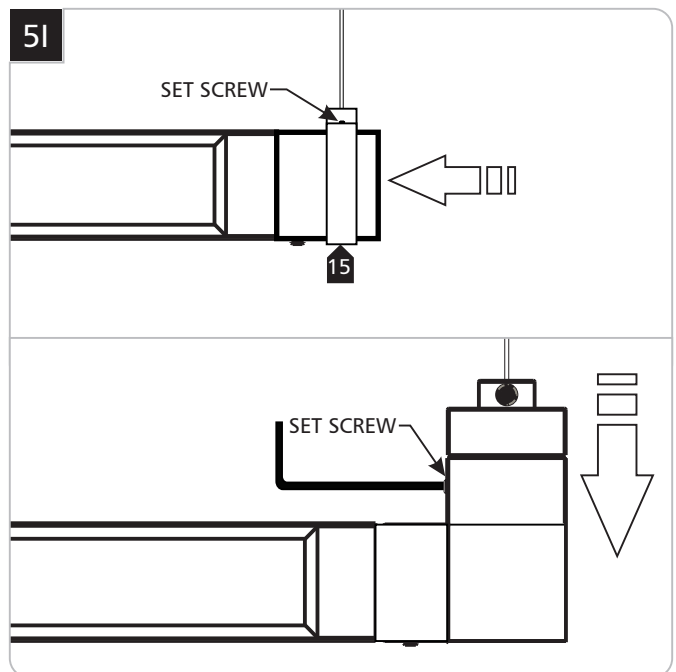

- 16 Slide the support bracket over the end cap or insert the connector support into the connector.
- 17 Secure by tightening the set screw on top of the bracket or on the side of the connector.

SAVE THESE INSTRUCTIONS!

TECH LIGHTING®
 7400 Linder Ave, Skokie, IL 60077
 847.410.4400

www.techlighting.com

© 2020 Tech Lighting, L.L.C. All rights reserved.
 Visual Comfort Group