

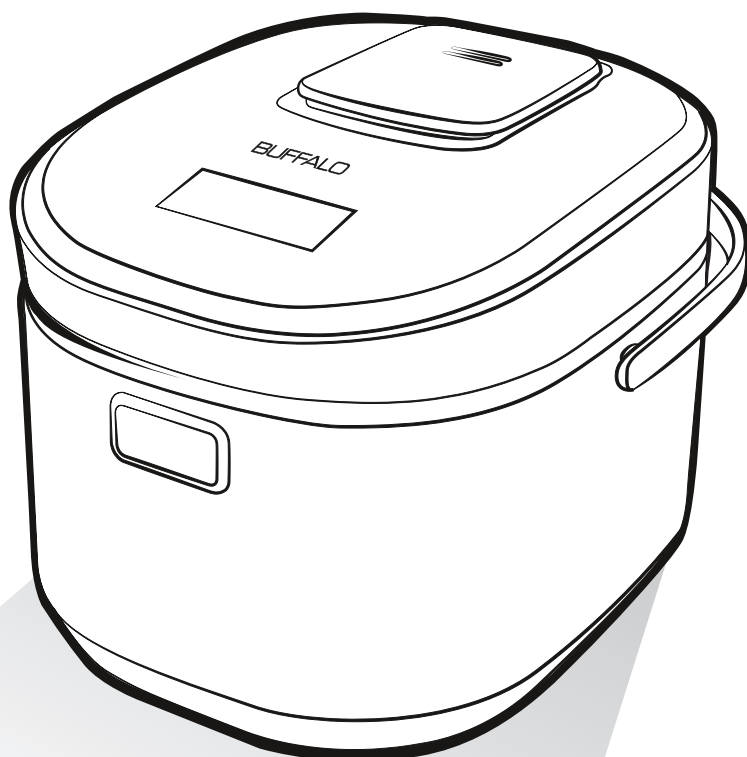

**BUFFALO**  
— since 1957 —

# INSTRUCTION MANUAL



**BUFFALO IH**

*Smart Cooker*



# Content

1. Precautions
2. Specifications
3. Features
4. Electrical Principles
5. Name of Components
6. How to use
7. Cook Function
8. Set up (Preset Timer)
9. Assembly / Disassembly of Steam Valve
10. Troubleshooting

**BUFFALO IH**  
*Smart Cooker*



1

USER MANUAL

## Precautions

---

In order to safely and correctly use this product, please pay attention to following precautions.

1. do NOT disassemble and repair this product by your own. If a repair is needed, please contact [info@buffalocookware.com.au](mailto:info@buffalocookware.com.au).
2. Ensure no flammable materials nearby. Do not use in extreme humid environment.
3. Ensure power cord is properly plugged to avoid any accident arising from electric shock, short circuit or fire.
4. Never allow children to operate the cooker nor allow infant nearby to avoid electric shock or heat related accidents.
5. Don't move the cooker in use. Plug off its power cord before moving.
6. Plug off the power cord when not in use.
7. NEVER cover the air vent of the cooker in use and put any object on its cover.
8. Don't open the cooker in use. Plug off or disconnect the power cord firstly.
9. Refrain from touching the inner cover, air vent, inner pot or heating coil during or after cooking.
10. Don't put the inner pot over cooktop or other heating equipment directly.
11. Assemble the overflow steam valve on the upper cover properly before use to avoid burn or damage to the cooker.
12. Plug off the power cord before cleaning the cooker. Never sink it into water.
13. If the power cord is damaged, please replace it with the equivalent from its manufacturer or any service store. Don't disassemble it by yourself.

## Specifications

Model	Category	Power supply	Rated power	Rated capacity	Quantity of rice (cup)
KW78	IH Smart Cooker	220V	1300W	1.5L	8 Cups
KW79	IH Smart Cooker	220V	1300W	1.8L	10 Cups

## Features

1. Full IMD touch control panel design.
2. Micro intelligent controller that automatically measures rice quantity, and allows cooking with intelligent temperature controls and micro-pressure stew that keeps natural nutrition and original taste.
3. New Technology Prevents Overflowing, Prevent Overcooking, Prevent Sticking, Prevent Electric Leakage and Anti-Slip Preventions.
4. The inner pot is made of Buffalo Clad which is resistant to oxidation, non-stick and has no chemical coating.
5. 1-hour intelligent power-cut memory function that prevents power failure.
6. Sensor-based circuit protection that assures safety.
7. Distinct cooking functions to meet diversified taste.
8. 24-hours timer preset function.

## Electrical Principles

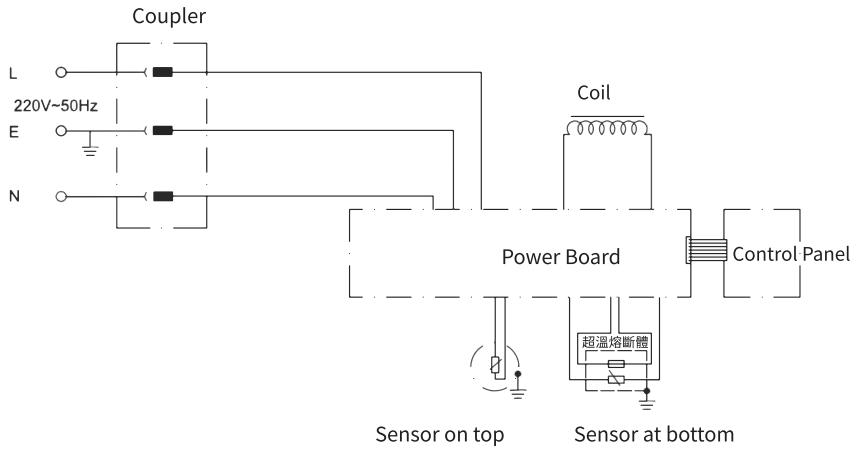

## Name of components

Configurations varies with model

Inner/Steel Lid

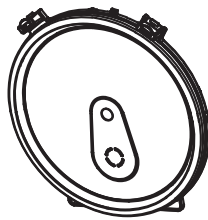

Button

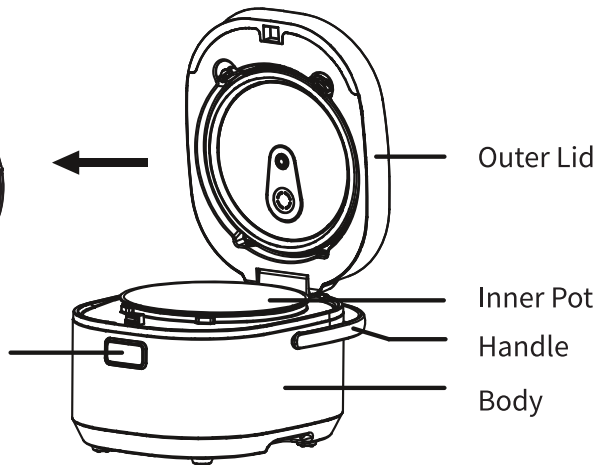



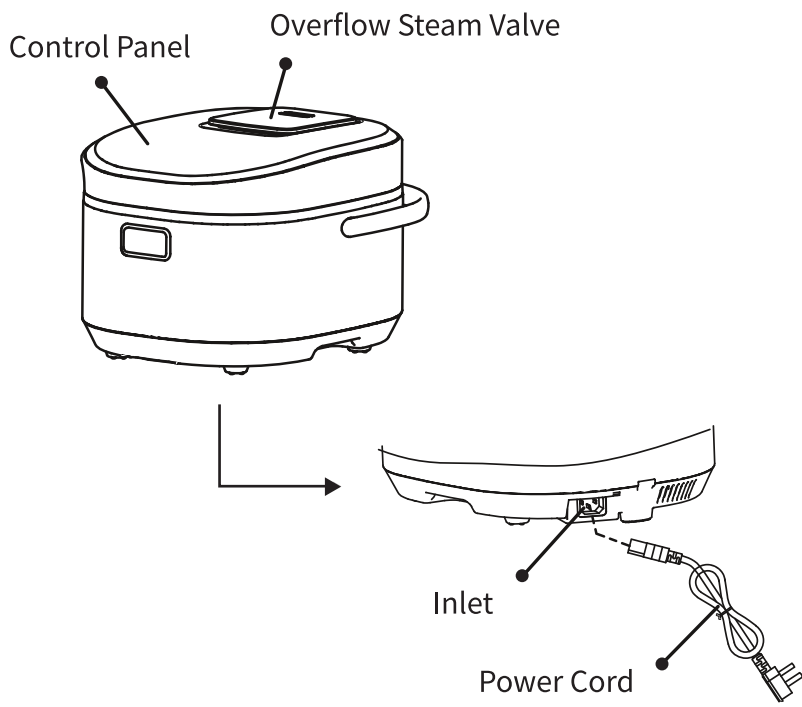

# Name of components

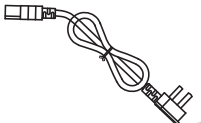

## Parts ( configurations varies with models )

Parts	 Measuring Cup	 Power Cord	 Rice Spoon	 Soup Spoon
-------	--	---	---	---



## How to use

1. Capacity is measured in the approximately 160ml rice measuring cup.
2. Always allow slightly extra water when you cook less than two cups.

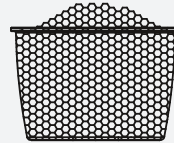
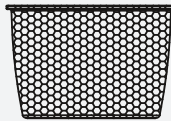
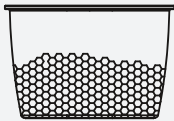

3. Turn off the power after the cooking is completed. Let the rice sit for 10 mins for better result.
4. You can wash rice directly in the stainless steel insert.



### About our Buffalo Clad inner pot

- Optimum thermal conductivity, fast & even heat distribution.
  - Fast gentle & even heat transmission, excellent heat retention.
  - Resistant to oxidation, no deformation and chemical reaction.
- \*304 Superior Stainless Steel turner is exquisitely made, durable and rustproof.

### Tips for cleaning : use hot water to remove stubborn stains

- Place hot water into the pot or pan. After water has reach room temperature, the rice should have loosened enough that you can easily scrap off. Continue with regular cleaning steps. Repeat the process if necessary.

### Troubleshooting

- It is normal to see a colorful, rainbow color or white spot in the pot due to high operating temperatures, and contact with mineral/starch. It is easily removable by using lemon or cooking oil.

## Cooking functions



### Fine cooking, ultra fast cooking

1. Press "Function" key to select the cooking options.



#### Two Cooking Modes:

Fine cooking : suitable for all varieties of rice to maximum capacity.

Ultrafast cooking: recommended for medium or lower level only.

2. "Taste" key lights up immediately after selecting "Fine" function. And then press "Taste" key to circularly select "Normal", "Hard" or "Soft".
3. After selecting a function, press and hold "Start" key for 1~2 seconds till the cooker operating.
4. Count-down timer will be turned on in the last cooking phrase on "Stew" mode.

All Functions goes to keep warm mode automatically after cooking is completed.

Caution: ONLY unplug power on stand-by mode





## Claypot rice

---

1. Preliminary preparation.
2. Plug in the power cord, and then press "Function", then select "Cured Rice in Clay Pot."
3. Press "Start" to start "Cured Rice in Clay Pot" procedure.
4. The cooker will beep to alert users to add ingredients.

### Note:

Medium or lower level only, consume as soon as cooking is completed.

## Grain rice

---

1. Preliminary preparation.
2. Plug in the power cord, and then press "Function", then select "Coarse Cereals."
3. Press "Start" to start "Grain rice" procedure.

### Cooking tips for coarse cereals:

( For 3 persons )

White rice - 1.5 cups, millet - 1/3 cups, red bean - 1/3 cups.

Sticky rice - 1/2 cup, high grain - 1/3 cups, salt - 1 spoon.

### Recipe:

- A. Put washed white rice, sticky rice, millet and high grain into a sieve.
- B. Boil red bean over high heat to medium or well done degree; soup will be needed for next step.
- C. Put white rice, sticky rice, millet and high grain into the inner pot, add the soup, and then add water to the 3rd Level.
- D. Add boiled red bean; close the top cover and select "Grain rice".



## Porridge / Soup, Steam

---

1. Preliminary preparation.
2. Plug in the power cord, and then press "Function", then select "Porridge/Soup, Steam."
3. Press "Timer" then use both "Hr" and "Min" keys to set the cooking time, or leave it at default cooking time.
4. Press "Start" to start "Porridge/Soup, Stewing" procedure.

Cooking option	Default time	Adjustable time
Porridge/Soup	2hrs	1-4hrs
Steam	20mins	10-40mins

## Cake

---

1. Preliminary preparation.
2. Plug in the power cord, and then press "Function", then select "Cake."
3. Press "Start" to start "Cake" procedure.

### Ingredients:

250g cake powder, 2 eggs, 100g water, 50g sugar, a little butter (about 5g)

### Note:

1. Max amount of the powder is 500g.
2. Too much sugar may cause the bottom of cake to burn. Measure sugar levels as accurate possible.



## Recipe:

1. Whip up the eggs uniformly.
2. Add the sugar into the egg liquid and stir them evenly.
3. Add water ( 3/4 needed amount) and stir the mix evenly ( till the sugar has completely dissolved in the water).
4. Add the cake powder and stir the ingredients ( add 1/4 needed water while stirring).
5. Add a little butter (if in solid state, slightly heat it till become liquid state)
6. And stir the ingredients evenly till it become the paste ready for cooking cake. Finally, coat a layer of oil (cooking oil or butter) on inner pot and put the paste in the inner pot; then put the pot in the cooker, select "Cake", and press "Start".

## Reheat

---

1. Plug in the power cord, then press "Function", then select "Reheat".
2. Press "Timer" then use "Min" key to set the cooking time, or leave it at default cooking time.
3. Press "Start" key to start "Reheat" procedure.

Cooking option	Default time	Adjustable time
Reheat	25mins	25-59mins

## Note:

- a. In case of reheating rice, rice must be stirred up to stay loose to avoid overcooking.
- b. In case of reheating rice, avoid using "reheat" repeatedly.
- c. In case of reheating rice, recommended level is medium or lower.



## Set up (Preset Timer)

1. After selecting option (Fine Cooking, Cured Rice in Clay Pot, Grain Rice, Porridge/Soup, Steaming and etc), press "Preset", "Time", "Hr" and "Min" indicators will light up.
2. Press "Hr" and "Min" keys to set time. ( Note: the time range is 0~24hrs).
3. After the time is set, press " Start" key for 1~2 seconds till the cooker starts.

### Note:

1. The preset time includes cooking time. The scheduled time is the time when cooking is completed.
2. If the time set ahead is too short, the cooking mode will be turned on immediately. Power outage would NOT stop appointment mode. The timer will remain on schedule. If power restore after the scheduled time, the cooker will start cooking immediately.

## Assembly/disassembly of steam valve

Turn anti-clockwise to disassemble, turn clockwise to assemble.

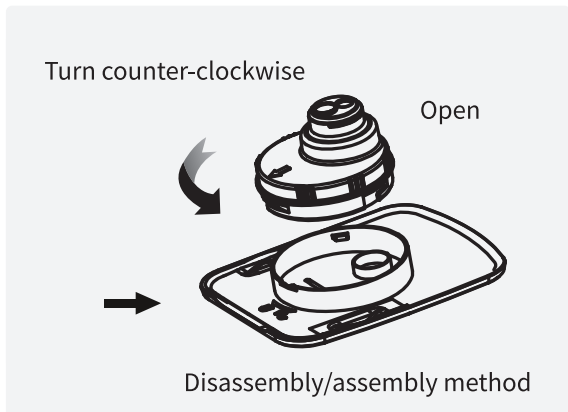



# Troubleshooting

Failure		Cause	Troubleshooting
Indicator does not light up	Coil not heating	<ol style="list-style-type: none"> <li>1. CB (circuit board power not connected)</li> <li>2. Power circuit board damaged</li> <li>3. CB disconnected</li> <li>4. MCB damaged</li> </ol>	Check switch, plug, thermal fuse and power lead for good condition and assemble in place;
	Coil heating	MCB damaged	Refer to service centre
Indicator lights up	Coil not heating	<ol style="list-style-type: none"> <li>1. Main temperature controller failed</li> <li>2. Coil element damaged</li> <li>3. CB partly disconnected</li> <li>4. Power circuit board damaged</li> </ol>	Refer to service centre
Rice does not fully cook or takes longer than normal		<ol style="list-style-type: none"> <li>1. Warming time too short</li> <li>2. Coil deformed</li> <li>3. Inner pot deflected</li> <li>4. Foreign matters between inner pot and heating coil</li> <li>5. Inner pot deformed</li> <li>6. MCB damaged</li> <li>7. Main temperature controller abnormal</li> </ol>	Refer to service center
Abnormal burnt rice and no auto keep warm		<ol style="list-style-type: none"> <li>1. Main temperature controller abnormal</li> <li>2. MCB damaged</li> </ol>	Refer to service centre
Overflows in porridge mode		<ol style="list-style-type: none"> <li>1. MCB damaged</li> <li>2. Temperature controller on top cover abnormal</li> <li>3. Foreign matters in steam valve</li> <li>4. Beyond max porridge level</li> <li>5. Cover improperly closed</li> <li>6. Incorrect function is selected</li> </ol>	<ol style="list-style-type: none"> <li>1. Refer to service centre</li> <li>2. Clean steam valve</li> <li>3. Adjust water to required level</li> <li>4. Close the cover properly</li> <li>5. Ensure correct function is selected.</li> <li>6. Refer to service centre</li> </ol>
Not boiling in rice or porridge cooking mode		<ol style="list-style-type: none"> <li>1. MCB damaged</li> <li>2. Temperature controller on top cover abnormal</li> </ol>	Refer to service centre

- Please contact our service centers or resellers at <http://buffalocookware.com.au> for repair and warranty enquiry.

