

# T-#24B, H CHIPPING HAMMER

# T-#34B, H CHIPPING HAMMER

# T-#44B, H CHIPPING HAMMER



**OILING INSTRUCTIONS:**  
**OIL AFTER EACH USE**  
**WITH A FEW DROPS OF**  
**AIRTOOL OIL THROUGH**  
**THE AIR INLET. RUN FOR**  
**1 SECOND TO COAT ALL**  
**INTERNAL PARTS.**

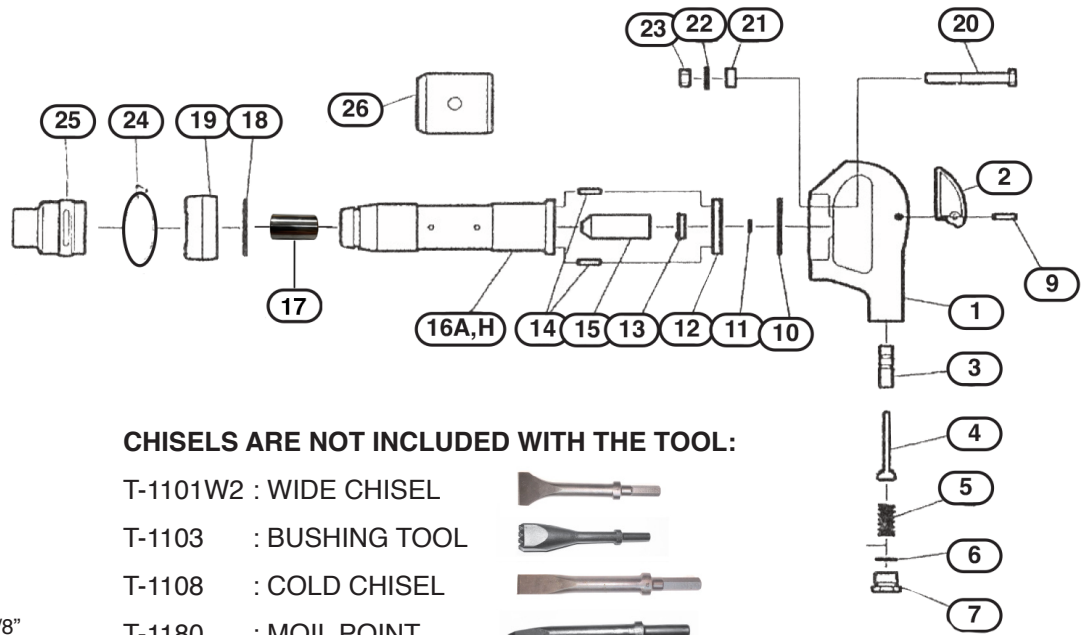

**OPTIONAL ACCESSORIES:**



T-7516 .680/.580 HEX  
 QUICK CHANGE  
 BALL TYPE RETAINER



T-23451 HOSE SWIVEL  
 3/8" NPT  
 FITS ANY TOOL WITH 3/8"  
 AIR INLET

**CHISELS ARE NOT INCLUDED WITH THE TOOL:**

T-1101W2 : WIDE CHISEL



T-1103 : BUSHING TOOL



T-1108 : COLD CHISEL



T-1180 : MOIL POINT



THESE CHISELS FIT OUR T-#24B, T-#34B, T-#44B, T-#2, T-#3 & T-#4 CHIPPING HAMMERS AS WELL AS ANY CHIPPING HAMMER THAT ACCEPTS .680 ROUND SHANK OVAL COLLAR CHISELS. FORGED STEEL. MADE IN USA. THE T-1103 IS 9 1/2" LONG. THE OTHER THREE CHISELS AVAILABLE IN 9", 12", OR 18" LENGTH. .580 HEX CHISELS ALSO AVAILABLE FOR "BH" HAMMERS

**USE 90 PSI MAXIMUM**

REF #	PART #	DESCRIPTION	QTY	REF #	PART #	DESCRIPTION	QTY
1	2344B01A	HANDLE ASSEMBLY (PARTS 1-9)	1	16H	24B16H	#2 CYLINDER W/.580 HEX	1
2	2344B02	TRIGGER	1	16H	34B16H	#3 CYLINDER W/.580 HEX	1
3	2344B03	THROTTLE BUSHING THROTTLE	1	16H	44B16H	#4 CYLINDER W/.580 HEX	1
4	2344B04	VALVE STEM THROTTLE SPRING	1	17	2344B17	ROUND BUSHING	1
5	2344B05	O-RING	1	17H	2344B17H	HEX BUSHING	1
6	2344B06	AIR INLET 3/8 NPT	1	18	2344B18	ABSORBER RING	1
7	2344B07	PIN	1	19	2344B19	CYLINDER FLANGE	1
9	2344B09	O-RING	1	20	2344B20	BOLT	4
10	2344B10	DISC VALVE	1	21	2344B21	VIBRATION SPACER	4
11	2344B11	VALVE SEAT	1	22	2344B22	WASHER	4
12	2344B12	VALVE SEAT BUMPER	1	23	2344B23	NUT (NYLOC)	4
13	2344B13	DOWEL PIN	1	24	2343N3	LOCKCOIL SPRING	1
14	2344B14	#2 PISTON	2	25	23431N3	SLEEVE-RETAINER	1
15	24B15	#3 PISTON	1	26	234B26	DEFLECTOR (#2 & #3)	1
15	34B15	#4 PISTON	1	26	44B26	DEFLECTOR (#4)	1
15	44B15	#2 CYLINDER W/.680 BUSHING	1			<b>OPTIONAL ACCESSORIES</b>	
16A	24B16A	#3 CYLINDER W/.680 BUSHING	1	T-7516		QUICK CHANGE RETAINER	
16A	34B16A	#4 CYLINDER W/.680 BUSHING	1	T-#23451		HOSE SWIVEL 3/8" NPT	
16A	44B16A		1				

505 N. Railroad Ave. 33435  
 P.O. Box 1117 33425  
 Boynton Beach, FL

FOR WARRANTY INFORMATION &  
 WARRANTY REGISTRATION VISIT

[www.taylorpneumatic.com](http://www.taylorpneumatic.com)

MARCH 2022 / ALL RIGHTS RESERVED / COPYRIGHT 2022

Ph. (561)732-1111  
 Fax. (561)731-4412  
 Toll Free (800) 805-8665