

T-9959REA

1/4" Super Duty Extended Die Grinder - Governor Controlled

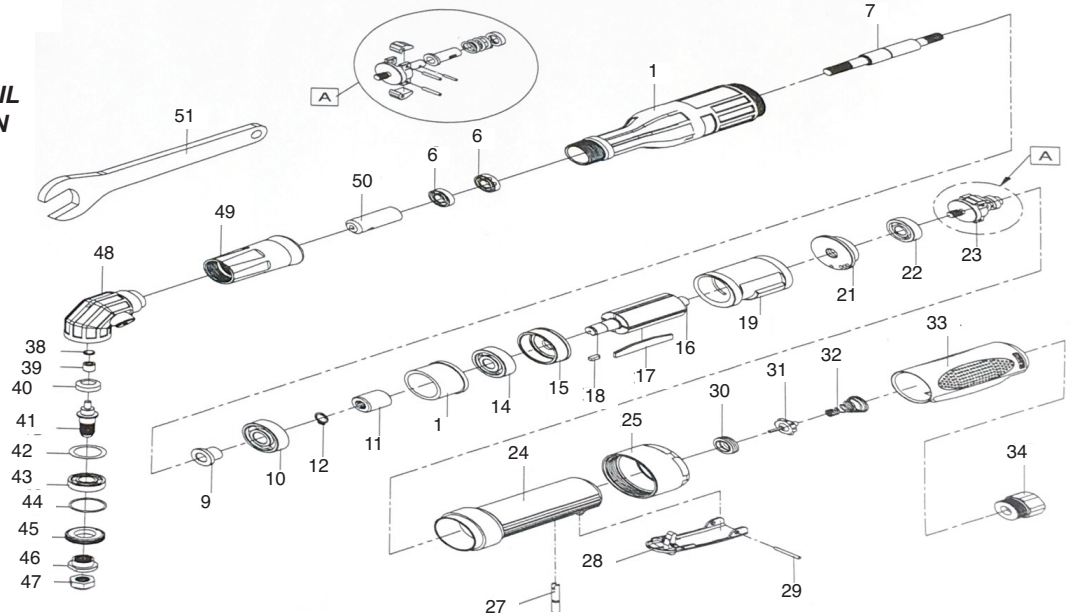

OILING INSTRUCTIONS:
OIL AFTER EACH USE WITH
1/2 TEASPOON OF AIRTOOL OIL
THROUGH THE AIR INLET. RUN
FOR ONE SECOND TO COAT
ALL INTERNAL PARTS



USE 90 PSI MAXIMUM

Ref #	Part #	Description	Qty.	Ref #	Part #	Description	Qty.
1	9957RE01	Housing	1	26	9957RE26	O-Ring	1
2	9957RE02	Collet Nut	1	27	9957RE27	Valve Stem	1
3	9957RE03	Collet	1	28	9957RE28	Throttle Lever	1
4	9957RE04	Bushing	1	29	9957RE29	Throttle Lever Pin	1
5	9957RE05	Cap	1	30	9957RE30	Valve Seat	1
6	9957RE06	Bearing	2	31	9957RE31	Throttle Valve	1
7	9957RE07	Spindle	1	32	9957RE32	Spring	1
8	9957RE08	Key	1	33	9957RE33	Grip	1
9	9957RE09	Bushing	1	34	9957RE34	Air Inlet	1
10	9957RE10	Bearing	1	38	9959REA38	Washer	1
11	9957RE11	Coupling	1	39	9959REA39	Needle Bearing	1
12	9957RE12	Retainer Ring	1	40	9959REA40	Gear	1
13	9957RE13	Reinforcing Ring	1	41	9959REA41	Collet H	1
14	9957RE14	Bearing	1	42	9959REA42	Wrench	1
15	9957RE15	Front End Plate	1	43	9959REA43	Collet Spindle	1
16	9957RE16	Rotor	1	44	9959REA44	Washer	1
17	9957RE17	Rotor Blade (4 per set)	1set	45	9959REA45	Bearing	1
18	9957RE18	Key	1	46	9959REA46	O-Ring	1
19	9957RE19	Cylinder	1	47	9959REA47	Collet Nut	1
20	9957RE20	Pin	1	48	9959REA48	Angle Head	1
21	9957RE21	Rear End Plate	1	49	9959REA49	Angle Housing	1
22	9957RE22	Bearing	1	50	9959REA50	Drive Spindle	1
23	9957RE23	Governor Cage	1	51	9949REA51	Wrench	1
24	9957RE24	Handle	1				
25	9957RE25	Connecting Nut	1				

505 N. Railroad Ave. 33435
P.O. Box 1117 33425
Boynton Beach, Florida

SEE OUR CATALOG
at
www.taylorpneumatic.com

0216TPTC /all rights reserved /COPYRIGHT 2016 / final

Ph. (561) 732-1111
Fax (561) 731-4412
Toll Free 800-805-8665

Operating Instructions for Die Grinders

GENERAL INFORMATION-

When a collet is attached to the output shaft of an airtool it is called a die grinder. It can have a straight handle or a pistol grip handle. Most of our die grinders will accept a 1/4" or 1/8" collets. The exceptions are the T-9930B & T-9930EXB's that have 3/8" collets. The four jawed collet we use on most die grinders gives the best grip and keeps the bit centered to minimize vibration. Make sure that the collet and collet holder are clean when installing a new bit, as chips and dirt in the collet can cause the tool to vibrate from being off center. The wrenches provided are used to tighten and loosen the collet nut. Check the collet nut periodically to keep it tight. When installing the bit (grinding stone, carbide burr, or cutoff wheel mandrel) push it in as far as it will go so that the actual working part of the bit is as close as possible to the collet nut, this ensures the best grip and minimizes vibration. Most die grinders have a built in regulator. Turning the valve with a flat bladed screwdriver will increase or decrease the amount of air going into the tool and increase or decrease the RPM. Use of a 3/8" air hose is recommended. Use the fewest number of quick disconnects possible to minimize air pressure drop. Air pressure at the tool should be 90 PSI or less. Using the least amount of pressure possible will allow you to get the maximum life from your tool. Small air compressors with tanks under 20 gallons may not provide enough air to maintain a constant 90 PSI.

Using too much air pressure is like driving your car at 200 MPH. Your car may go that fast, but will the tires, engine and bearings hold up? Excess air pressure can cause premature wear or tool failure. Most of our tools have safety levers that can prevent accidental starts. Removal is not recommended. Never drag a tool by the air hose, doing so can bend the rotor shaft causing permanent damage. Always check a die grinder, if it is dropped, for damage to the bit or a bent rotor shaft. The differences in die grinders is tremendous - pencil die grinders are used for fine work where size and weight are important. They come standard with 1/8" collets but 3/32" and 3mm collets are available. These tools also have overhoses for directing the exhaust away from the operator. The size of your job, as well as the amount of material to be removed, dictates the size of the die grinder you need to use. Pencil Grinders for light work in tight areas, the .25HP tools for light to medium material removal, the .45HP and .5HP units for heavy material removal. For really heavy duty jobs, use the .9HP tools. To keep dirt and grinding dust out of your tools, store them in plastic ziplock bags after oiling. If you have specific questions call us at 800-805-8665.

SAFETY FIRST

Wearing safety glasses and the right clothing are important. Die grinders are usually high speed tools that can throw sparks and

grinding dust for several feet. Goggles are needed to protect your eyes, long sleeves will help protect your arms. The use of a full face shield may also be required. It is recommended that you remove jewelry such as rings and watches. Depending on how you use the tool, you may need to wear protective gloves. Hearing protection is needed when using a die grinder for extended periods of time. The stream of sparks (in the case of steel) or removed material (in the case of aluminum, wood or non-ferrous materials) can cause a fire or injury to a bystander. Pay attention to people around you and to the direction of the spark stream.

OILING

Oiling your tool at the end of every day is extremely important. Add one or two tablespoons of a commercial airtool oil like our T-8004, T-8032 or T-8128 through the air inlet. Run the tool for a second or two to coat all internal parts. This will help prevent rust from forming.

TAYLOR Airtool oil is custom blended to improve the life and performance of airtools. It will emulsify with water to protect against rust, and will loosen and flush out built up sludge and dirt.

T-8128
Gal. Air
Tool Oil



T-8032
Qt Air
Tool Oil



T-8004
4oz Air
Tool Oil

