

# T-9857R .9HP

## 1/4" Straight Die Grinder

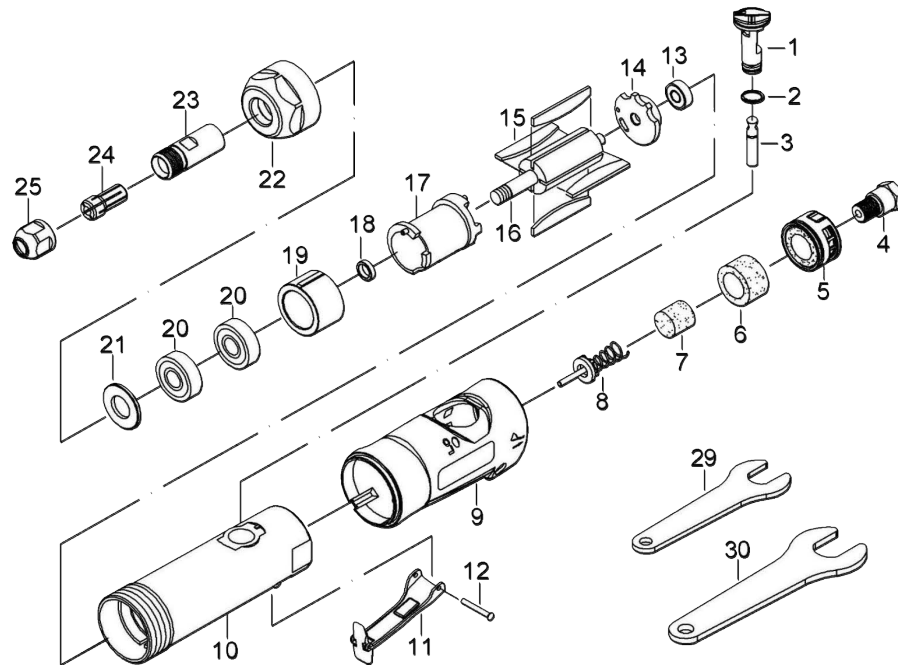

**OILING  
INSTRUCTIONS:**  
OIL AFTER EACH  
USE WITH A FEW  
DROPS OF  
AIRTOOL OIL  
THROUGH THE AIR  
INLET. RUN  
FOR 1 SECOND TO  
COAT ALL INTERNAL  
PARTS



**USE 90 PSI MAXIMUM**

Ref #	Part #	Description	Qty.	Ref #	Part #	Description	Qty.
1	9859R01	Regulator Set	1	16	9859R16	Rotor	1
2	9859R02	Snap Ring	1	17	9859R17	Cylinder Set	1
3	9859R03	Valve Stem Set	1	18	9859R18	Bearing Spacer	1
4	9859R04	Air Inlet	1	19	9859R19	Front Plate	1
5	9859R05	Muffler Set	1	20	9859R20	Bearing	2
6	9859R06	Silencer	1	21	9857R21	Washer	1
7	9859R07	Silencer	1	22	9857R22	Clamp Nut	1
8	9859R08	Valve Set	1	23	9857R23	Spindle	1
9	9859R09	Protective Rubber	1	24	9859R24	Collet	1
10	9859R10	Housing	1	25	9859R25	Collet Nut	1
11	9859R11	Safety Lever	1	29	9859R29	Spanner 14MM	1
12	9859R12	Spring Pin	1	30	9859R30	Spanner 19MM	1
13	9859R13	Bearing	1				
14	9859R14	Rear Plate	1				
15	9859R15	Rotor Blade (4)	1 set				

505 N. Railroad Ave. 33435  
P.O. Box 1117 33425  
Boynton Beach, Florida

FOR WARRANTY INFORMATION &  
WARRANTY REGISTRATION VISIT  
[www.taylorpneumatic.com](http://www.taylorpneumatic.com)

10/23TPTC /all rights reserved /COPYRIGHT 2023 / final

Ph. (561) 732-1111  
Fax (561) 731-4412  
Toll Free 800-805-8665