

T-9758R 1/4" Super Duty Die Grinder

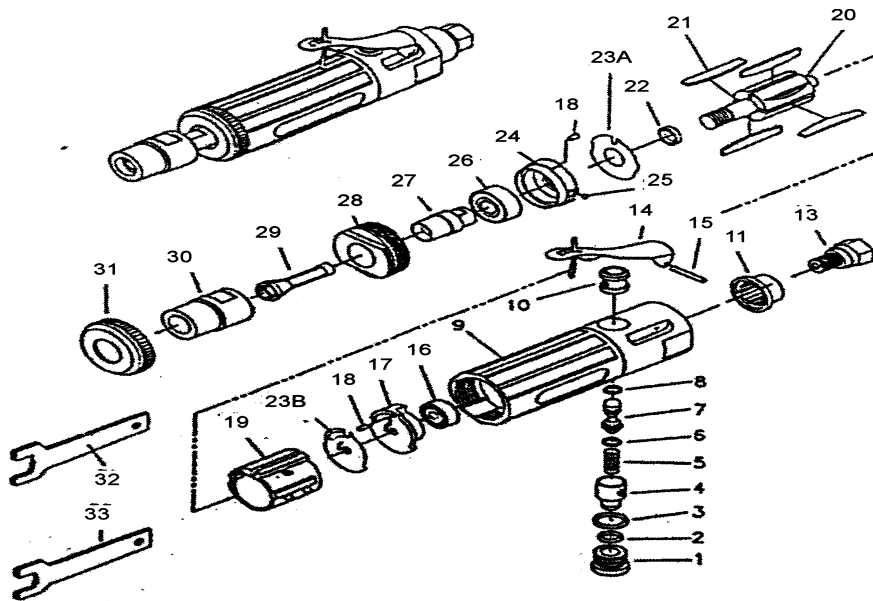

OILING INSTRUCTIONS:
OIL AFTER EACH USE WITH
1/2 TEASPOON OF AIRTOOL OIL
THROUGH THE AIR INLET. RUN
FOR ONE SECOND TO COAT
ALL INTERNAL PARTS

USE 90 PSI MAXIMUM

Ref #	Part #	Description	Qty.	Ref #	Part #	Description	Qty.
1	9758R01N3	Plug	1	21	9758R21N3	Rotor Blades (4 per set)	1set
2	9758R02N3	O-Ring	1	23	9758R22N3	Spacer	1
3	9758R03N3	O-Ring	1	23A	9758R23AN	Steel Plate	1
4	9758R04N3	Regulator	1	23B	9758R23BN	Steel Plate	1
5	9758R05N3	Spring	1	24	9758R24N3	Front End Plate	1
6	9758R06N3	O-Ring	1	25	9758R25N3	Ball	1
7	9758R07N3	Valve Stem	2	26	9758R26N3	Bearing	1
8	9758R08N3	O-Ring	1	27	9758R27N3	Collet Foundation	1
9	9758R09N3	Motor Housing	1	28	9758R28N3	Lock Ring	1
10	9758R10N3	Valve Bushing	1	29	T-75084	1/4" Collet	1
11	9758R11N3	Muffler	1	29	T-7508	1/8" Collet (optional)	
13	9758R13N3	Air Inlet	1	30	9758R30N3	Collet Nut	1
14	9758R14N3	Lever	2	31	9758R31N3	Housing Cap	1
15	9758R15N3	Pin	2	32	9758R32N3	Wrench 11mm	1
16	9758R16N3	Bearing	1	33	9758R33N3	Wrench 17mm	1
17	9758R17N3	Rear End Plate	1				
18	9758R18N3	Pin	2				
19	9758R19N3	Cylinder	1				
20	9758R20N3	Rotor	1				

505 N. Railroad Ave. 33435
P.O. Box 1117 33425
Boynton Beach, Florida

SEE OUR CATALOG
at
www.taylorpneumatic.com

0116TPTC /all rights reserved /COPYRIGHT 2016 / final

Ph. (561) 732-1111
Fax (561) 731-4412
Toll Free 800-805-8665

Operating Instructions for Die Grinders

GENERAL INFORMATION-

When a collet is attached to the output shaft of an airtool it is called a die grinder. It can have a straight handle or a pistol grip handle. Most of our die grinders will accept a 1/4" or 1/8" collets. The exceptions are the T-9930B & T-9930EXB's that have 3/8" collets. The four jawed collet we use on most die grinders gives the best grip and keeps the bit centered to minimize vibration. Make sure that the collet and collet holder are clean when installing a new bit, as chips and dirt in the collet can cause the tool to vibrate from being off center. The wrenches provided are used to tighten and loosen the collet nut. Check the collet nut periodically to keep it tight. When installing the bit (grinding stone, carbide burr, or cutoff wheel mandrel) push it in as far as it will go so that the actual working part of the bit is as close as possible to the collet nut, this ensures the best grip and minimizes vibration. Most die grinders have a built in regulator. Turning the valve with a flat bladed screwdriver will increase or decrease the amount of air going into the tool and increase or decrease the RPM. Use of a 3/8" air hose is recommended. Use the fewest number of quick disconnects possible to minimize air pressure drop. Air pressure at the tool should be 90 PSI or less. Using the least amount of pressure possible will allow you to get the maximum life from your tool. Small air compressors with tanks under 20 gallons may not provide enough air to maintain a constant 90 PSI.

Using too much air pressure is like driving your car at 200 MPH. Your car may go that fast, but will the tires, engine and bearings hold up? Excess air pressure can cause premature wear or tool failure. Most of our tools have safety levers that can prevent accidental starts. Removal is not recommended. Never drag a tool by the air hose, doing so can bend the rotor shaft causing permanent damage. Always check a die grinder, if it is dropped, for damage to the bit or a bent rotor shaft. The differences in die grinders is tremendous - pencil die grinders are used for fine work where size and weight are important. They come standard with 1/8" collets but 3/32" and 3mm collets are available. These tools also have overhoses for directing the exhaust away from the operator. The size of your job, as well as the amount of material to be removed, dictates the size of the die grinder you need to use. Pencil Grinders for light work in tight areas, the .25HP tools for light to medium material removal, the .45HP and .5HP units for heavy material removal. For really heavy duty jobs, use the .9HP tools. To keep dirt and grinding dust out of your tools, store them in plastic ziplock bags after oiling. If you have specific questions call us at 800-805-8665.

SAFETY FIRST

Wearing safety glasses and the right clothing are important. Die grinders are usually high speed tools that can throw sparks and



grinding dust for several feet. Goggles are needed to protect your eyes, long sleeves will help protect your arms. The use of a full face shield may also be required. It is recommended that you remove jewelry such as rings and watches. Depending on how you use the tool, you may need to wear protective gloves. Hearing protection is needed when using a die grinder for extended periods of time. The stream of sparks (in the case of steel) or removed material (in the case of aluminum, wood or non-ferrous materials) can cause a fire or injury to a bystander. Pay attention to people around you and to the direction of the spark stream.

OILING

Oiling your tool at the end of every day is extremely important. Add one or two tablespoons of a commercial airtool oil like our T-8004, T-8032 or T-8128 through the air inlet. Run the tool for a second or two to coat all internal parts. This will help prevent rust from forming.

TAYLOR Airtool oil is custom blended to improve the life and performance of airtools. It will emulsify with water to protect against rust, and will loosen and flush out built up sludge and dirt.



T-8128
Gal. Air
Tool Oil



T-8032
Qt Air
Tool Oil



T-8004
4oz Air
Tool Oil