

T-8875 3/4" Impact Wrench T-8875L 3/4" Impact Wrench w/6" extended anvil

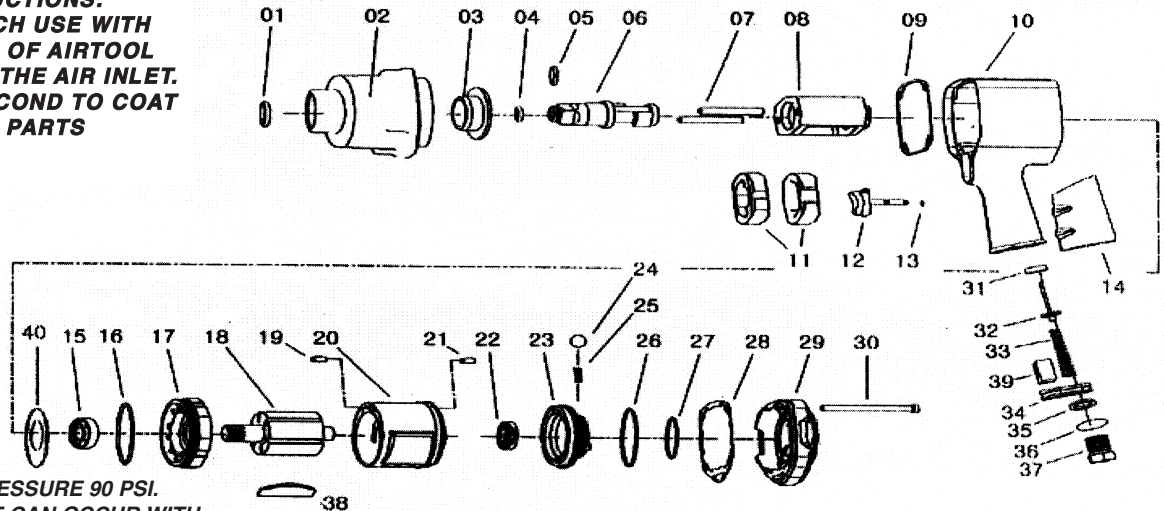

OILING INSTRUCTIONS:
OIL AFTER EACH USE WITH
1/2 TEASPOON OF AIRTOOL
OIL THROUGH THE AIR INLET.
RUN FOR 1 SECOND TO COAT
ALL INTERNAL PARTS



USE MAX. AIR PRESSURE 90 PSI.
CLUTCH DAMAGE CAN OCCUR WITH
HIGHER PRESSURE.

USE 90 PSI MAXIMUM

Ref #	Part #	Description	Qty.	Ref #	Part #	Description	Qty.
1	887501	Oil Seal	1	22	887522	Bearing	1
2	887502	Hammer Case	1	23	887523	Reverse Lever	1
3	887503	Bushing	1	24	887524	Ball	1
4	887504	O-Ring	1	25	887525	Spring	1
5	887505	Anvil Collar	1	26	887526	O-Ring	1
6	887506	Anvil	1	27	887527	O-Ring	1
	8875L06	Extended Anvil 6"	1	28	887528	Rear Gasket	1
7	887507	Hammer Pin	2	29	887529	Rear Cover	1
8	887508	Hammer Cage	1	30	887530	Bolt	4
9	887509	Front Gasket	1	31	887531	Retainer	1
10	887510	Motor Housing	1	32	887532	Valve Stem	1
11	887511	Hammer Dog	2	33	887533	Spring	1
12	887512	Trigger	1	34	887534	Exhaust Deflector	1
13	887513	O-Ring	1	35	887535	Washer	1
14	887514	Grip	1	36	887536	O-Ring	1
15	887515	Bearing	1	37	887537	Air Inlet	1
16	887516	O-Ring	1	38	887538	Rotor Blades (6 per set)	1 set
17	887517	Front End Plate	1	39	887539	Muffler	1
18	887518	Rotor	1	40	887540	Washer	1
19	887519	Pin	1				
20	887520	Cylinder	1				
21	887521	Pin	1				

SEE OUR CATALOG

at

www.taylorpneumatic.com

505 N Railroad Ave. 33435
P.O. Box 1117 33425
Boynton Beach, Florida

PH. 561-732-1111
FAX 561-731-4412
TOLL FREE 800-805-8665

General Instructions Impact Wrenches

PLEASE READ AND FOLLOW ALL WARNINGS

An impact wrench is an amazing time saving machine. If its strengths and weaknesses are taken into consideration it can be used for years of trouble free service. Always use 90 PSI Maximum AT THE TOOL. Using higher air pressures can prematurely wear parts and strain parts not designed for the higher pressure. In most instances, within the first five seconds of use, an impact wrench develops its maximum torque. If a fastener is still not moving try penetrating oil or a larger impact wrench. Always use impact sockets. Always oil your airtools before storing. Put a few spoonfuls of airtool oil in the air inlet and run the tool for a second or two to coat internal parts.

OILING INSTRUCTIONS:

OIL AFTER EACH USE WITH 2 OR 3 TABLESPOONS OF AIRTOOL OIL THROUGH THE AIR INLET. RUN FOR ONE SECOND TO COAT ALL INTERNAL PARTS. 1/4" TO 1/2" IMPACTS USUALLY USE 30 WT. NON DETERGENT OIL IN THE HAMMER CASE. WRENCHES 3/4" TO 1-1/2" USUALLY USE GREASE IN THE HAMMER CASE.

IMPACT WRENCHES - GENERAL INSTRUCTIONS

- 1. ALWAYS DISCONNECT THE TOOL FROM AIR SOURCE WHEN CHANGING ACCESSORIES OR SERVICING THE TOOL.*
- 2. CHECK ALL FASTENERS DAILY. BOLTS MUST BE KEPT TIGHT TO MAINTAIN SAFETY AND TOP TOOL OPERATING PERFORMANCE.*
- 3. STAY IN CONTROL OF THE IMPACT WRENCH*
- 4. ALWAYS USE IMPACT SOCKETS - STANDARD SOCKETS MAY BE BRITTLE AND BREAK CAUSING DAMAGE TO THE OPERATOR OR THE TOOL.*
- 5. VIBRATION MAY BE HARMFUL TO YOUR ARMS AND HANDS. WEAR PROTECTION.*
- 6. INSPECT THE TOOL AND AIR SUPPLY AND AIR HOSE ON A REGULAR BASIS.*
- 7. DO NOT MAKE CONTACT WITH ELECTRICAL LINES.*
- 8. LEAVE TRIGGER OFF BEFORE CONNECTING THE TOOL TO THE AIR SUPPLY. AVOID ACCIDENTAL STARTS.*
- 9. WEAR THE PROPER CLOTHING. DO NOT WEAR JEWELRY, LOOSE CLOTHING, OR LONG HAIR AS IT CAN GET CAUGHT IN ROTATING PARTS. KEEP GLOVES AWAY FROM ROTATING PARTS.*
- 10. DO NOT WORK IN HAZARDOUS ATMOSPHERES WHERE SPARKS COULD IGNITE OR DETONATE FUMES.*
- 11. WATCH WHAT YOU ARE DOING. USE COMMON SENSE WHEN OPERATING PNEUMATIC TOOLS. DO NOT USE PNEUMATIC TOOLS WHEN TIRED OR UNDER THE INFLUENCE OF MEDICATION, ALCOHOL OR DRUGS. SERIOUS PERSONAL INJURY MAY RESULT FROM A MOMENTS INATTENTION.*
- 12. USE 90 PSI AT THE TOOL. USE 3/8", 1/2" or 3/4" HOSE OR LARGER WITH FITTINGS 9/32 MINIMUM I.D. AS SPECIFIED*
- 13. DO NOT WORK IN HAZARDOUS ATMOSPHERES WHERE SPARKS COULD IGNITE OR DETONATE FUMES.*
- 14. WATCH WHAT YOU ARE DOING. USE COMMON SENSE WHEN OPERATING PNEUMATIC TOOLS. DO NOT USE PNEUMATIC TOOLS WHEN TIRED OR UNDER THE INFLUENCE OF MEDICATION, ALCOHOL OR DRUGS. SERIOUS PERSONAL INJURY MAY RESULT FROM A MOMENTS INATTENTION.*
- 15. USE 90 PSI AT THE TOOL. USE 3/8", 1/2" or 3/4" HOSE OR LARGER WITH FITTINGS 9/32 MINIMUM I.D. AS SPECIFIED*
- 16. ONLY USE CLEAN DRY COMPRESSED AIR. NEVER USE OXYGEN, CARBON DIOXIDE, COMBUSTIBLE GASES OR ANY OTHER BOTTLED GAS TO POWER THIS TOOL.*
- 17. STORE TOOLS IN A CLEAN DRY ENVIRONMENT.*
- 18. DO NOT USE DAMAGED TOOLS - MARK, AND RETURN DAMAGED TOOLS FOR SERVICE.*
- 19. NEVER FORCE THE TOOL. LET THE TOOL DO THE WORK.*
- 20. STOP USE IMMEDIATELY IF TOOL IS MAKING AN UNUSUAL NOISE OR VIBRATION. HAVE TOOL CHECKED BY PROFESSIONAL TECHNICIAN.*
- 21. KEEP CHILDREN, PETS AND BYSTANDERS AWAY WHILE OPERATING A PNEUMATIC TOOL. DISTRACTIONS CAN CAUSE YOU TO LOSE CONTROL.*
- 22. THESE WARNINGS AND INSTRUCTIONS CAN NOT COVER ALL POSSIBLE CONDITIONS OR SITUATIONS. THE OPERATOR MUST UNDERSTAND THAT COMMON SENSE AND CAUTIONS ARE FACTORS WHICH CAN NOT BE BUILT INTO THE PRODUCT BUT MUST BE SUPPLIED BY THE OPERATOR.*

ADDITIONAL INFORMATION IS AVAILABLE FROM:

**AMERICAN NATIONAL STANDARDS INSTITUTE
11 WEST 42ND ST.
NEW YORK, NY 10036**

REQUEST A COPY OF ANSI B186.1 SAFETY CODE FOR PORTABLE AIR TOOLS.

LIMITED LIFETIME WARRANTY

Most products of Taylor Pneumatic are warranted to be free from defects in material and workmanship for the life of the tool. This warranty applies to the original purchaser only. This warranty does not cover tools that have been abused, misused, modified, not properly lubricated or to normal wear and tear. Taylor Pneumatic will at its option repair or replace the defective product free of charge except for shipping. Taylor Pneumatics sole liability and your exclusive remedy under this warranty is limited to the repair or replacement of the defective product. There are no other warranties expressed or implied and Taylor Pneumatic shall not be liable for incidental, consequential, or special damages, expenses or costs except as described above. WARRANTY VOID IF TOOL IS DISASSEMBLED. Return tools to **Taylor Pneumatic**. Be sure to include your name, address, proof of purchase and description of the suspected defect.

This warranty applies to the basic tool. It does not apply to wear and tear on accessories or consumables such as drill chucks, backing pads for sanders, punch and dies for nibblers, spray gun cups or accessories from a kit.