

T-8859RS Angle Sander

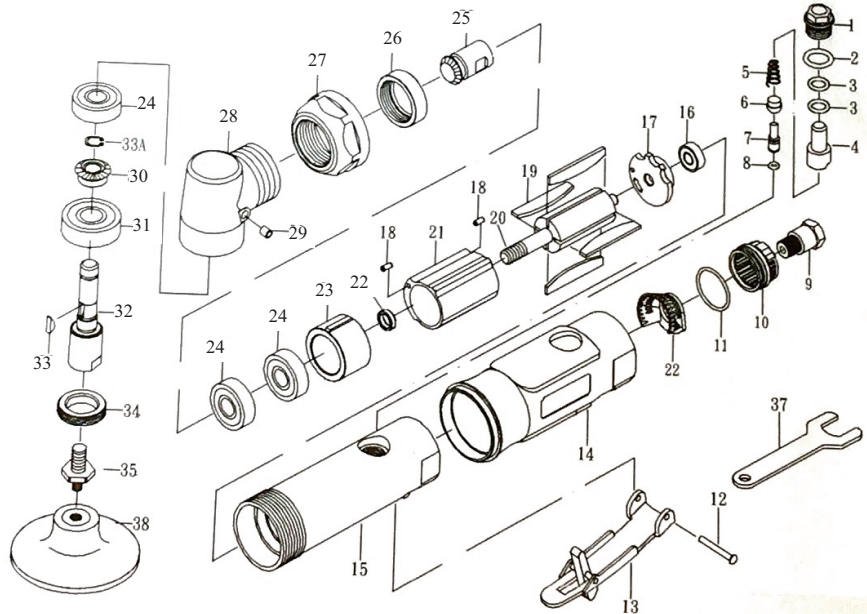

OILING INSTRUCTIONS:
OIL AFTER EACH USE WITH 1/2
TEASPOON OF AIRTOOL OIL
THROUGH THE AIR INLET. RUN
FOR ONE SECOND TO COAT
ALL INTERNAL PARTS



USE 90 PSI MAXIMUM

Ref #	Part #	Description	Qty.	Ref #	Part #	Description	Qty.
1	8859R01	Screw	1	26	8859RS26	Nut	1
2	8859R02	O-Ring	1	27	8859R27	Clamp Nut	1
3	8859R03	O-Ring	2	28	8859R28	Angle Housing	1
4	8859R04	Air Regulator	1	29	8859R29	Grease Fitting	1
5	8859R05	Spring	1	30	8859RS30	Bevel Gear	1
6	8859R06	Valve Stem Bushing	1	31	8859R31	Bearing	1
7	8859R07	Valve Stem	1	32	8859RS32	Shaft	1
8	8859R08	O-Ring	1	33	8859RS33	2mm Key	1
9	8859R09	Air Inlet	1	34	8859S34	Clamp Nut	1
10	8859R10	Exhaust Sleeve	1	35	T-8859RS50	Adapter	1
11	8859R11	O-Ring	1	37	8859RS37	Wrench	1
12	8859R12	Spring Pin	1	38	T-8859RS51	Pad	1
13	8859R13	Lever	1				
14	8859R14	Protecting Rubber	1				
15	8859R15	Housing	1				
16	8859R16	Bearing	1				
17	8859R17	Rear Plate	1				
18	8859R18	Pin	2				
19	8859R19	Rotor Blade (set of 4)	1 set				
20	8859RS20	Rotor	1				
21	8859R21N	Cylinder	1				
22	8859R22	Bearing Spacer	1				
22A	8859R22A	Cone Muffler	1				
23	8859R23	Front End Plate	2				
24	8859R24	Bearing	1				
25	8859R25	Bevel Gear	1				

505 N. Railroad Ave. 33435
P.O. Box 1117 33425
Boynton Beach, Florida

SEE OUR CATALOG
at
www.taylorpneumatic.com

0216TPTC /all rights reserved /COPYRIGHT 2016 / final

Ph. (561) 732-1111
Fax (561) 731-4412
Toll Free 800-805-8665

General Instructions Sanders



OIL AFTER EACH USE WITH 1/2 TABLESPOON OF AIR-TOOL OIL THROUGH THE AIR INLET. RUN FOR ONE SECOND TO COAT ALL INTERNAL PARTS.

IMPORTANT WARNING:

WHEN RUNNING SANDERS, ALWAYS KEEP THE SAND-PAPER ON THE WORK SURFACE.

USE 90 PSI MAX.

1. ALWAYS DISCONNECT THE TOOL FROM AIR SOURCE WHEN CHANGING ACCESSORIES OR SERVICING THE TOOL.
2. USE SAFETY GLASSES, FULL FACE SHIELDS, HEARING PROTECTION AND GLOVES.
3. STAY IN CONTROL OF THE SANDER - DO NOT OVER REACH.
4. ALWAYS REMOVE WRENCHES FROM THE TOOL AFTER SERVICING. WRENCHES LEFT ATTACHED MAY RESULT IN SERIOUS HARM TO THE OPERATOR.
5. VIBRATION MAY BE HARMFUL TO YOUR ARMS AND HANDS. WEAR PROTECTION.
6. INSPECT THE TOOL AND AIR SUPPLY ON A REGULAR BASIS.
7. DO NOT REMOVE GUARDS OR SAFETY DEVICES. DO NOT MODIFY OR DEFEAT SAFETY DEVICES.
8. DO NOT MAKE CONTACT WITH ELECTRICAL LINES.
9. LEAVE TRIGGER OFF BEFORE CONNECTING THE TOOL TO THE AIR SUPPLY. AVOID ACCIDENTAL STARTS.
10. WEAR THE PROPER CLOTHING. DO NOT WEAR JEWELRY, LOOSE CLOTHING, OR LONG HAIR AS IT CAN GET CAUGHT IN ROTATING PARTS. KEEP GLOVES AWAY FROM ROTATING PARTS.
11. DO NOT WORK IN HAZARDOUS ATMOSPHERES WHERE SPARKS COULD IGNITE OR DETONATE FUMES.
12. WATCH WHAT YOU ARE DOING. USE COMMON SENSE WHEN OPERATING PNEUMATIC TOOLS. DO NOT USE PNEUMATIC TOOLS WHEN TIRED OR UNDER THE INFLUENCE OF MEDICATION, ALCOHOL OR DRUGS. SERIOUS PERSONAL INJURY MAY RESULT FROM A MOMENTS INATTENTION.
13. USE 90 PSI AT THE TOOL. USE 3/8" HOSE OR LARGER WITH FITTINGS 9/32 MINIMUM I.D.
14. ONLY USE CLEAN DRY COMPRESSED AIR. NEVER USE OXYGEN, CARBON DIOXIDE, COMBUSTIBLE GASES OR ANY OTHER BOTTLED GAS TO POWER THIS TOOL.
15. SECURE YOUR WORK BEFORE STARTING - USE CLAMPS OR FIND A SUITABLE WAY TO MAINTAIN STABILITY.
16. STORE TOOLS IN A CLEAN DRY ENVIRONMENT.
17. DO NOT USE DAMAGED TOOLS - MARK, AND RETURN FOR SERVICE.
18. NEVER FORCE THE TOOL. LET THE TOOL DO THE WORK.

19. STOP USE IMMEDIATELY IF TOOL IS MAKING AN UNUSUAL NOISE OR VIBRATION. HAVE TOOL CHECKED BY PROFESSIONAL TECHNICIAN.
 20. OPERATE AT RATED TOOL SPEED.
 21. ALWAYS USE **SANDING PADS WITH A MAXIMUM SPEED RATING EQUAL TO OR GREATER THAN THE LABELED SPEED OF THE TOOL.**
 22. WORK IN A WELL VENTILATED AREA AND USE APPROVED PERSONAL PROTECTIVE EQUIPMENT SUCH AS DUST MASKS, THAT ARE SPECIFICALLY DESIGNED TO FILTER OUT MICROSCOPIC PARTICLES. SOME DUST CREATED BY POWER SANDING, SAWING, GRINDING AND OTHER CONSTRUCTION ACTIVITIES CONTAIN CHEMICALS KNOWN TO CAUSE CANCER, BIRTH DEFECTS OR OTHER REPRODUCTIVE HARM. SOME EXAMPLES OF THESE CHEMICALS ARE: CRYSTALLINE SILICA FROM BRICKS, CEMENT AND OTHER MASONARY PRODUCTS, ARSENIC AND CHROMIUM FROM CHEMICALLY TREATED LUMBER AND LEAD FROM LEAD BASED PAINTS. YOUR RISK FROM EXPOSURE VARIES, DEPENDING ON HOW OFTEN YOU DO THIS TYPE OF WORK. TO REDUCE YOUR EXPOSURE TO THESE CHEMICALS WEAR PROTECTIVE MASKS AND CLOTHING.
 23. KEEP CHILDREN, PETS AND BYSTANDERS AWAY WHILE OPERATING A PNEUMATIC TOOL. DISTRACTIONS CAN CAUSE YOU TO LOSE CONTROL. PROTECT OTHERS IN THE WORK AREA FROM DEBRIS SUCH AS METAL FILINGS AND SPARKS. PROVIDE BARRIERS OR SHIELDS AS NEEDED.
24. THESE WARNINGS AND INSTRUCTIONS CAN NOT COVER ALL POSSIBLE CONDITIONS OR SITUATIONS. THE OPERATOR MUST UNDERSTAND THAT COMMON SENSE AND CAUTIONS ARE FACTORS WHICH CAN NOT BE BUILT INTO THE PRODUCT BUT MUST BE SUPPLIED BY THE OPERATOR.

LIMITED LIFETIME WARRANTY

Most products of Taylor Pneumatic are warranted to be free from defects in material and workmanship for the life of the tool. This warranty applies to the original purchaser only. This warranty does not cover tools that have been abused, misused, modified, not properly lubricated or to normal wear and tear. Taylor Pneumatic will at its option repair or replace the defective product free of charge except for shipping. Taylor Pneumatics sole liability and your exclusive remedy under this warranty is limited to the repair or replacement of the defective product. There are no other warranties expressed or implied and Taylor Pneumatic shall not be liable for incidental, consequential, or special damages, expenses or costs except as described above. **WARRANTY VOID IF TOOL IS DISASSEMBLED.** Return tools to Taylor Pneumatic. Be sure to include your name, address, proof of purchase, and description of the suspected defect.

This warranty applies to the basic tool. It does not apply to wear and tear on accessories or consumables such as drill chucks, backing pads for sanders, punch and dies for nibblers, spray gun cups, or accessories from a kit.

505 N. Railroad Ave. 33435
P.O. Box 1117 33425
Boynton Beach, Florida

SEE OUR CATALOG
at
www.taylorpneumatic.com

Ph. (561) 732-1111
Fax (561) 731-4412
Toll Free 800-805-8665