

T-8801R 4" Reversible Angle Cutoff Tool

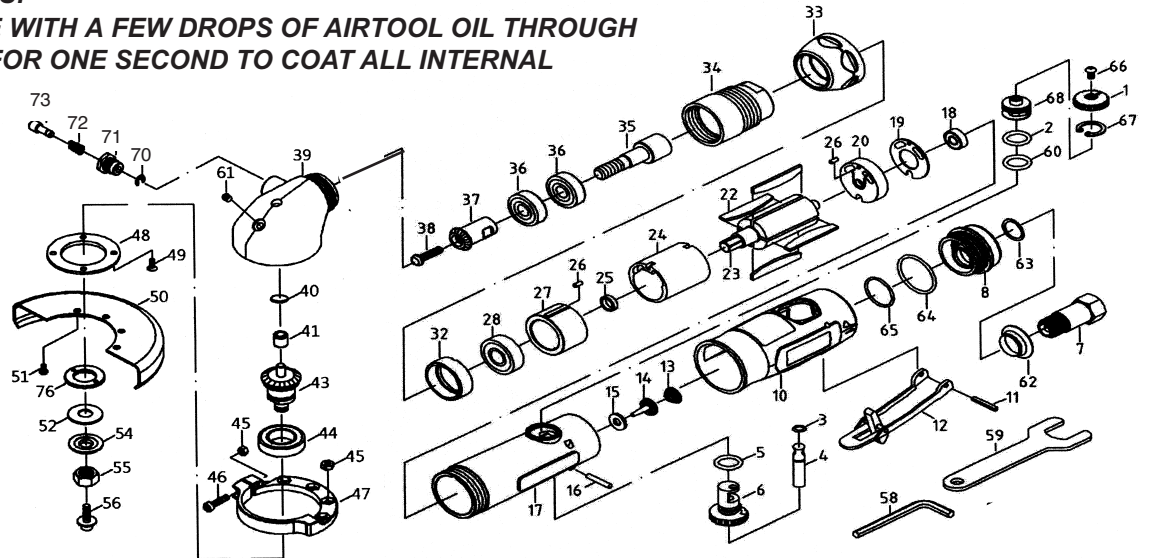

OILING INSTRUCTIONS:

OIL AFTER EACH USE WITH A FEW DROPS OF AIRTOOL OIL THROUGH THE AIR INLET. RUN FOR ONE SECOND TO COAT ALL INTERNAL PARTS.



Always use the #55 nut to secure the wheel to the tool. The #56 screw (M5-12) must also be used because the tool is reversible

USE 90 PSI MAXIMUM

Ref #	Part #	Description	Qty.	Ref #	Part #	Description	Qty.
1	8801R01	Fwd/Rev Knob	1	43	8801R43	Arbor Gear	1
2	8801R02	O-Ring	1	44	8801R44	Bearing	1
3	8801R03	O-Ring	1	45	8801R45	Nut	5
4	8801R04	Valve Stem	1	46	8801R46	Screw	1
5	8801R05	O-Ring	1	47	8801R47	Clamp	1
6	8801R06	Regulator	1	48	8801R48	Ring	1
7	8801R07	Air Inlet	1	49	8801R49	Screw	4
8	8801R08	Muffler	1	50	8801R50	Guard	1
10	8801R10	Cover	1	51	8801R51	Screw	4
11	8801R11	Pin	1	52	8801R52	Washer	1
12	8801R12	Lever	1	54	8801R54	Washer	1
13	8801R13	Spring	1	55	8801R55	Nut	1
14	8801R14	Valve	1	56	8801R56	Screw	1
15	8801R15	Valve Seat	1	58	8801R58	Allen Wrench (4mm)	1
16	8801R16	Pin	1	59	8801R59	Open End Wrench (17mm)	1
17	8801R17	Housing	1	60	8801R60	O-Ring	1
18	8801R18	Bearing	1	61	8801R61	Grease Fitting	1
19	8801R19	Gasket	1	62	8801R62	Muffler	1
20	8801R20	Rear End Plate	1	63	8801R63	Washer	1
22	8801R22	Rotor Blade (4 per set)	1set	64	8801R64	O-Ring	1
23	8801R23	Rotor	1	65	8801R65	O-Ring	1
24	8801R24	Cylinder	1	66	8801R66	Screw	1
25	8801R25	Spacer	1	67	8801R67	Snap Ring	1
26	8801R26	Pin	2	68	8801R68	FWD/REV Valve	1
27	8801R27	Front End Plate	1	69	8801R69	Nut	1
28	8801R28	Bearing	1	70	8801R70	Snap Ring	1
32	8801R32	Nut	1	71	8801R71	Nut	1
33	8801R33	Clamp Nut	1	72	8801R72	Spring	1
34	8801R34	Front Housing	1	73	8801R73	Pin	1
35	8801R35	Drive Shaft	1	74	9801341	4"Cutoff Wheel (not shown)	1
36	8801R36	Bearing	2				
37	8801R37	Gear	1				
38	8801R38	Screw	1				
39	8801R39N	Angle Housing	1				
40	8801R40	Shield	1				
41	8801R41	Bearing	1				

505 N. Railroad Ave. 33435
P.O. Box 1117 33425
Boynton Beach, Florida

FOR WARRANTY INFORMATION &
WARRANTY REGISTRATION VISIT
www.taylorpneumatic.com

Ph. (561) 732-1111
Fax (561) 731-4412
Toll Free 800-805-8665