

T-8600/T-8600CG 6" Horizontal Grinder/ Cone & Plug Grinder

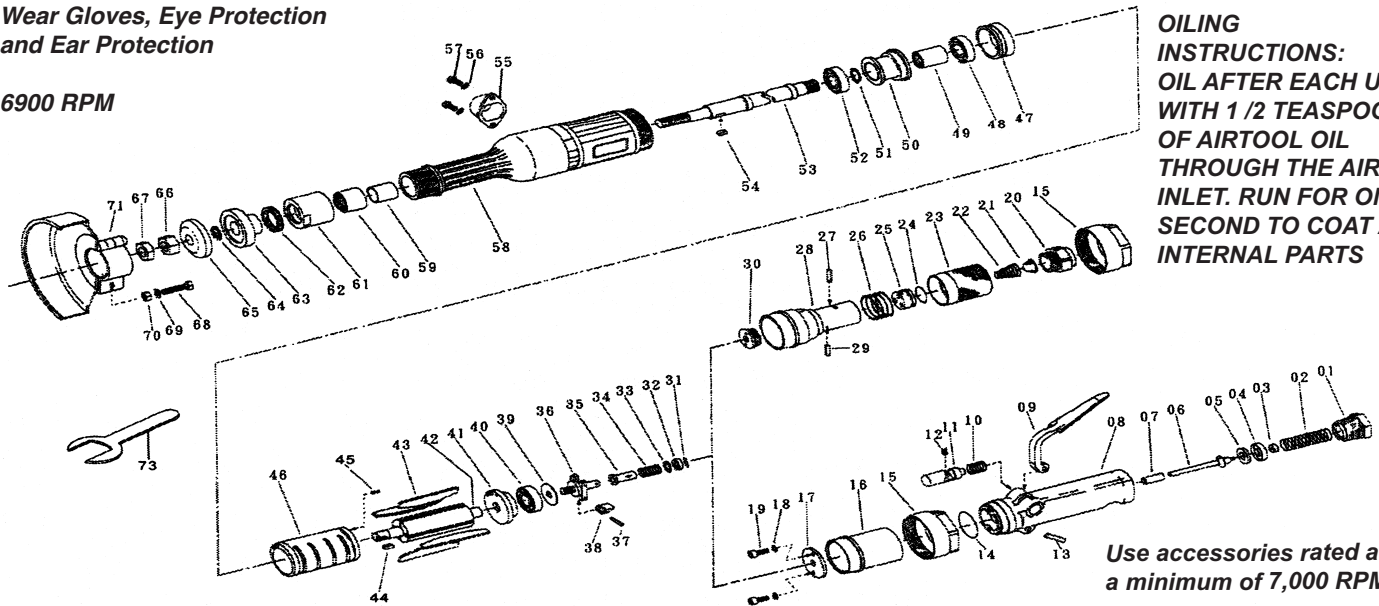

**Wear Gloves, Eye Protection
and Ear Protection**

6900 RPM



**OILING
INSTRUCTIONS:**
OIL AFTER EACH USE
WITH 1/2 TEASPOON
OF AIRTOOL OIL
THROUGH THE AIR
INLET. RUN FOR ONE
SECOND TO COAT ALL
INTERNAL PARTS

**Use accessories rated at
a minimum of 7,000 RPM**

USE 90 PSI MAXIMUM

Ref #	Part #	Description	Qty.	Ref #	Part #	Description	Qty.
1	860001	Air Inlet	1	38	860038	Governor Weight	2
2	860002	Spring	1	39	860039	Bearing Cover	1
3	860003	Sub Throttle Valve	1	40	860040	Bearing	1
4	860004	Washer	1	41	860041	Cylinder Upper Plate	1
5	860005	Throttle Valve	1	42	860042	Rotor	1
6	860006	Throttle Valve Rod	1	43	860043	Rotor Blade (Set of 4)	1 set
7	860007	Throttle Valve Bushing	1	44	860044	Key	1
8	860008	Throttle Valve Body	1	45	860045	Spring Pin	1
9	860009	Throttle Valve Lever	1	46	860046	Cylinder	1
10	860010	Lock Spring	1	47	860047	Lower End Plate	1
11	860011	Lock Key	1	48	860048	Bearing	1
12	860012	Set Screw	1	49	860049	Coupling	1
13	860013	Needle Roller	1	50	860050	Spacer	1
14	860014	O-Ring	1	51	860051	Snap Ring	1
15	860015	Nut	1	52	860052	Bearing	1
16	860016	Housing Cover	1	53	860053	Spindle	1
17	860017	Washer	1	53A	8600CG53	Spindle	1
18	860018	Spring Washer	2	54	860054	Key	1
19	860019	Cap Screw	2	55	860055	Exhaust Cover	1
20	860020	Throttle Valve Cover	1	56	860056	Spring Washer	2
21	860021	Strainer	1	57	860057	Screw	2
22	860022	Throttle Valve Spring	1	58	860058	Housing	1
23	860023	Throttle Valve Handle	1	59	860059	Inner Race	1
25	860025	Throttle Valve	1	60	860060	Needle Bearing	1
26	860026	Handle Spring	1	61	860061	Spindle Bearing Cover	1
27	860027	Pin	1	62	860062	Felt Ring	1
28	860028	Housing Cover	1	63	860063	Wheel Flange	1
29	860029	Needle Roller	1	64	860064	Snap Ring	1
30	860030	Bushing	1	65	860065	Exhaust Cover	1
31	860031	Needle Roller	1	66	860066	Nut	1
32	860032	Governor Spring Holder	1	67	860067	Nut	1
33	860033	Adjusting Washer	1	68	860068	Hex Bolt	1
34	860034	Governor Spring	1	69	860069	Spring Washer	1
35	860035	Governor Valve	1	70	860070	Nut	1
36	860036	Governor Cage	1	71	860071	Guard	1
37	860037	Pin	2	73	860073	Wrench 50 mm	1

505 N. Railroad Ave. 33435
P.O. Box 1117 33425
Boynton Beach, Florida

SEE OUR CATALOG
at
www.taylorpneumatic.com

0116TPTC /all rights reserved /COPYRIGHT 2016 / final

Ph. (561) 732-1111
Fax (561) 731-4412
Toll Free 800-805-8665