

T-8005 One Shot Air Hammer

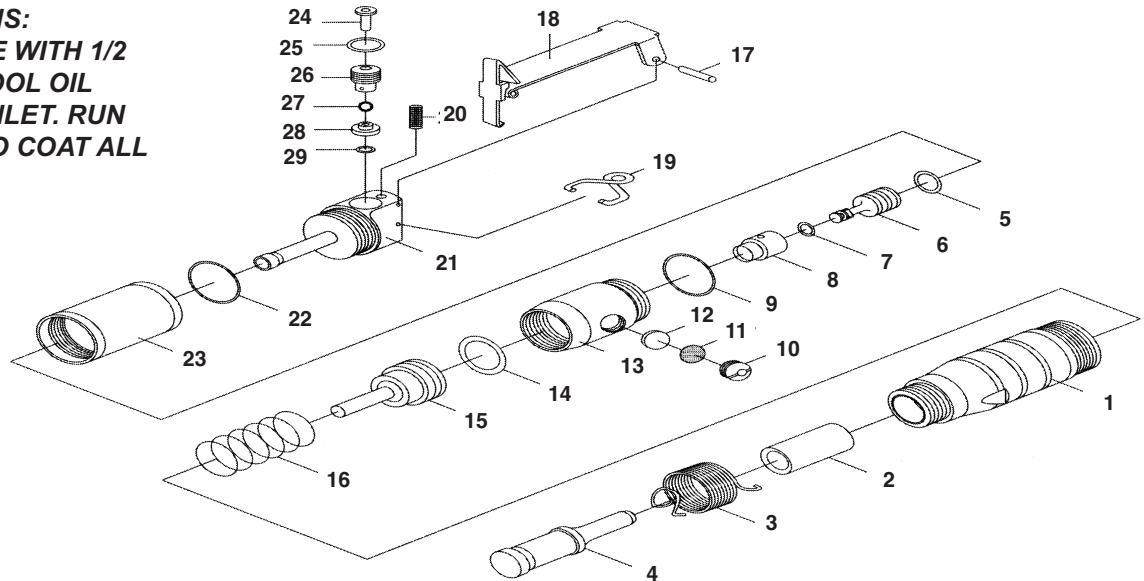

OILING INSTRUCTIONS:
OIL AFTER EACH USE WITH 1/2
TEASPOON OF AIRTOOL OIL
THROUGH THE AIR INLET. RUN
FOR ONE SECOND TO COAT ALL
INTERNAL PARTS



USE 90 PSI MAXIMUM

Ref #	Part #	Description	Qty.	Ref #	Part #	Description	Qty.
1	800501	Head Cylinder	1	16	800516	Piston Return Spring	1
2	800502	Bush	1	17	800517	Spring Pin	1
3	800503	Snap Stopper Spring	1	18	800518	Lever	1
4	800504	Rivet Snap	1	19	800519	N-Hook	1
5	800505	O-Ring	1	20	800520	Lever Return Spring	1
6	800506	Valve Piston	1	21	800521	Switch Body	1
7	800507	O-Ring	1	22	800522	O-Ring	2
8	800508	Valve	1	23	800523	Chamber	1
9	800509	O-Ring	1	24	800524	Air Pin	1
10	800510	Silencer Cap	1	25	800525	O-Ring	1
11	800511	Silencer Net	1	26	800526	Stop Screw	1
12	800512	Silencer Felt	1	27	800527	Urethane Ball	1
13	800513	Unit Cylinder	1	28	800528	Valve	1
14	800514	O-Ring	1	29	800529	O-Ring	1
15	800515	Hit Piston	1				

505 N. Railroad Ave. 33435
P.O. Box 1117 33425
Boynton Beach, Florida

SEE OUR CATALOG
at
www.taylorpneumatic.com

0116TPTC /all rights reserved /COPYRIGHT 2015 / final

Ph. (561) 732-1111
Fax (561) 731-4412
Toll Free 800-805-8665