

# T-7775 Heavy Duty 3/4" Impact Wrench

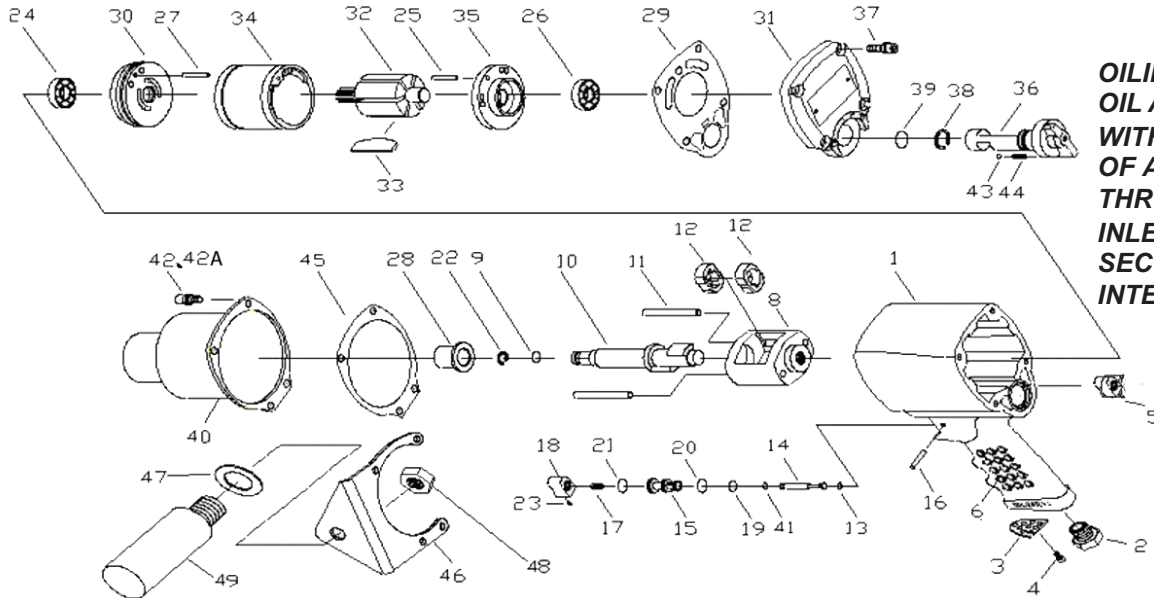

**OILING INSTRUCTIONS:**  
**OIL AFTER EACH USE**  
**WITH A COUPLE DROPS**  
**OF AIR TOOL OIL**  
**THROUGH THE AIR**  
**INLET. RUN FOR ONE**  
**SECOND TO COAT ALL**  
**INTERNAL PARTS**

## USE 90 PSI MAXIMUM

Ref #	Part #	Description	Qty.	Ref #	Part #	Description	Qty.
1	777501	Housing	1	26	777526	Bearing	1
2	777502	Air Inlet	1	27	777527	Pin	1
3	777503	Exhaust Deflector	1	28	777528	Bushing	1
4	777504	Screw	1	29	777529	Gasket	1
5	777505	Valve Sleeve	1	30	777530	Front End Plate	1
6	777506	Rubber Grip	1	31	777531	Rear Cover	1
8	777508	Hammer Cage	1	32	777532	Rotor	1
9	777509	O-Ring	1	33	777533	Rotor Blades (6 per set)	1
10	777510	Anvil	1	34	777534	Cylinder	1 set
11	777511	Hammer Pin	2	35	777535	Rear End Plate	1
12	777512	Hammer	2	36	777536	Regulator Knob	1
13	777513	O-Ring	1	37	777537	Screw and Washer	4
14	777514	Valve Stem	1	38	777538	Retaining Ring	1
15	777515	Valve Bushing	1	39	777539	O-Ring	1
16	777516	Spring Pin	1	40	777540	Housing Cover	1
17	777517	Spring	1	41	777541N	O-Ring	1
18	777518	Trigger	1	42	777542	Screw and Washer	4
19	777519	O-Ring	1	42A	777542A	Screw/Washer(Optional)	4
20	777520	O-Ring	1	43	777543	Ball	1
21	777521	O-Ring	1	44	777544	Spring	1
22	777522	Anvil Collar	1	45	777545	Gasket	1
23	777523	Set Screw	1	46	777546	Plate (Optional)	1
24	777524	Bearing	1	47	777547	Washer (Optional)	1
25	777525	Pin	1	48	777548	Nut (Optional)	1
				49	777549	Side Handle (Optional)	1

505 N. Railroad Ave. 33435  
P.O. Box 1117 33425  
Boynton Beach, Florida

FOR WARRANTY INFORMATION &  
WARRANTY REGISTRATION VISIT  
[www.taylorpneumatic.com](http://www.taylorpneumatic.com)

1122 TPTC /all rights reserved /COPYRIGHT 2022 / final

Ph. (561) 732-1111  
Fax (561) 731-4412  
Toll Free 800-805-8665

# General Instructions Impact Wrenches

## PLEASE READ AND FOLLOW ALL WARNINGS

An impact wrench is an amazing time saving machine. If its strengths and weaknesses are taken into consideration it can be used for years of trouble free service. Always use 90 PSI Maximum AT THE TOOL. Using higher air pressures can prematurely wear parts and strain parts not designed for the higher pressure. In most instances, within the first five seconds of use, an impact wrench develops its maximum torque. If a fastener is still not moving try penetrating oil or a larger impact wrench. Always use impact sockets. Always oil your airtools before storing. Put a few spoonfuls of airtool oil in the air inlet and run the tool for a second or two to coat internal parts.

### **OILING INSTRUCTIONS:**

*OIL AFTER EACH USE WITH 2 OR 3 TABLESPOONS OF AIRTOOL OIL THROUGH THE AIR INLET. RUN FOR ONE SECOND TO COAT ALL INTERNAL PARTS. 1/4" TO 1/2" IMPACTS USAULY USE 30 WT. NON DETERGENT OIL IN THE HAMMER CASE. WRENCHES 3/4" TO 1-1/2" USUALLY USE GREASE IN THE HAMMER CASE.*

### **IMPACT WRENCHES - GENERAL INSTRUCTIONS**

1. ALWAYS DISCONNECT THE TOOL FROM AIR SOURCE WHEN CHANGING ACCESSORIES OR SERVICING THE TOOL.
2. CHECK ALL FASTENERS DAILY. BOLTS MUST BE KEPT TIGHT TO MAINTAIN SAFETY AND TOP TOOL OPERATING PERFORMANCE.
3. STAY IN CONTROL OF THE IMPACT WRENCH
4. ALWAYS USE IMPACT SOCKETS - STANDARD SOCKETS MAY BE BRITTLE AND BREAK CAUSING DAMAGE TO THE OPERATOR OR THE TOOL.
5. VIBRATION MAY BE HARMFUL TO YOUR ARMS AND HANDS. WEAR PROTECTION.
6. INSPECT THE TOOL AND AIR SUPPLY AND AIR HOSE ON A REGULAR BASIS.
7. DO NOT MAKE CONTACT WITH ELECTRICAL LINES.
8. LEAVE TRIGGER OFF BEFORE CONNECTING THE TOOL TO THE AIR SUPPLY. AVOID ACCIDENTAL STARTS.
9. WEAR THE PROPER CLOTHING. DO NOT WEAR JEWELRY, LOOSE CLOTHING, OR LONG HAIR AS IT CAN GET CAUGHT IN ROTATING PARTS. KEEP GLOVES AWAY FROM ROTATING PARTS.
10. DO NOT WORK IN HAZARDOUS ATMOSPHERES WHERE SPARKS COULD IGNITE OR DETONATE FUMES.
11. WATCH WHAT YOU ARE DOING. USE COMMON SENSE WHEN OPERATING PNEUMATIC TOOLS. DO NOT USE PNEUMATIC TOOLS WHEN TIRED OR UNDER THE INFLUENCE OF MEDICATION, ALCOHOL OR DRUGS. SERIOUS PERSONAL INJURY MAY RESULT FROM A MOMENTS INATTENTION.
12. USE 90 PSI AT THE TOOL. USE 3/8", 1/2" or 3/4" HOSE OR LARGER WITH FITTINGS 9/32 MINIMUM I.D. AS SPECIFIED
13. DO NOT WORK IN HAZARDOUS ATMOSPHERES WHERE SPARKS COULD IGNITE OR DETONATE FUMES.
14. WATCH WHAT YOU ARE DOING. USE COMMON SENSE WHEN OPERATING PNEUMATIC TOOLS. DO NOT USE PNEUMATIC TOOLS WHEN TIRED OR UNDER THE INFLUENCE OF MEDICATION, ALCOHOL OR DRUGS. SERIOUS PERSONAL INJURY MAY RESULT FROM A MOMENTS INATTENTION.
15. USE 90 PSI AT THE TOOL. USE 3/8", 1/2" or 3/4" HOSE OR LARGER WITH FITTINGS 9/32 MINIMUM I.D. AS SPECIFIED
16. ONLY USE CLEAN DRY COMPRESSED AIR. NEVER USE OXYGEN, CARBON DIOXIDE, COMBUSTIBLE GASES OR ANY OTHER BOTTLED GAS TO POWER THIS TOOL.
17. STORE TOOLS IN A CLEAN DRY ENVIRONMENT.
18. DO NOT USE DAMAGED TOOLS - MARK, AND RETURN DAMAGED TOOLS FOR SERVICE.
19. NEVER FORCE THE TOOL. LET THE TOOL DO THE WORK.
20. STOP USE IMMEDIATELY IF TOOL IS MAKING AN UNUSUAL NOISE OR VIBRATION. HAVE TOOL CHECKED BY PROFESSIONAL TECHNICIAN.
21. KEEP CHILDREN, PETS AND BYSTANDERS AWAY WHILE OPERATING A PNEUMATIC TOOL. DISTRACTIONS CAN CAUSE YOU TO LOSE CONTROL.
22. THESE WARNINGS AND INSTRUCTIONS CAN NOT COVER ALL POSSIBLE CONDITIONS OR SITUATIONS. THE OPERATOR MUST UNDERSTAND THAT COMMON SENSE AND CAUTIONS ARE FACTORS WHICH CAN NOT BE BUILT INTO THE PRODUCT BUT MUST BE SUPPLIED BY THE OPERATOR.

**ADDITIONAL INFORMATION IS AVAILABLE FROM:  
AMERICAN NATIONAL STANDARDS INSTITUTE  
11 WEST 42ND ST.  
NEW YORK, NY 10036**

**REQUEST A COPY OF ANSI B186.1 SAFETY CODE FOR PORTABLE AIR TOOLS.**

### **LIMITED LIFETIME WARRANTY**

Most products of Taylor Pneumatic are warranted to be free from defects in material and workmanship for the life of the tool. This warranty applies to the original purchaser only. This warranty does not cover tools that have been abused, misused, modified, not properly lubricated or to normal wear and tear. Taylor Pneumatic will at its option repair or replace the defective product free of charge except for shipping. Taylor Pneumatics sole liability and your exclusive remedy under this warranty is limited to the repair or replacement of the defective product. There are no other warranties expressed or implied and Taylor Pneumatic shall not be liable for incidental, consequential, or special damages, expenses or costs except as described above. WARRANTY VOID IF TOOL IS DISASSEMBLED. Return tools to **Taylor Pneumatic**. Be sure to include your name, address, proof of purchase and description of the suspected defect.

This warranty applies to the basic tool. It does not apply to wear and tear on accessories or consumables such as drill chucks, backing pads for sanders, punch and dies for nibblers, spray gun cups or accessories from a kit.