

T-7765N Jitterbug Sander

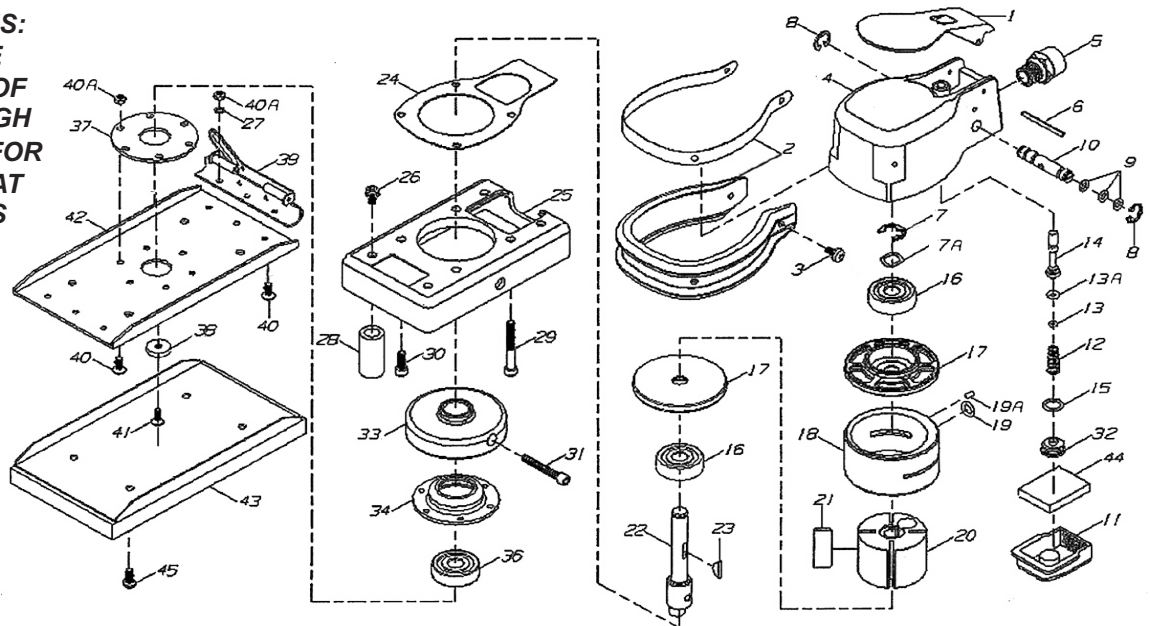

OILING INSTRUCTIONS:
OIL AFTER EACH USE
WITH A FEW DROPS OF
AIRTOOL OIL THROUGH
THE AIR INLET. RUN FOR
ONE SECOND TO COAT
ALL INTERNAL PARTS



USE 90 PSI MAXIMUM

| Ref # | Part # | Description | Qty. | Ref # | Part # | Description | Qty. |
|-------|----------|-------------------------|------|-------|----------|-------------------------|------|
| 1 | 7765N01 | Lever | 1 | 21 | 7765N21 | Rotor Blade (4 per set) | 1set |
| 2 | 7765N02 | Rubber Grip/Metal Strip | 1 | 22 | 7765N22 | Rotor Shaft | 1 |
| 3 | 7765N03 | Screw | 4 | 23 | 7765N23 | Key | 1 |
| 4 | 7765N04 | Body | 1 | 24 | 7765N24 | Gasket | 1 |
| 5 | 7765N05 | Inlet | 1 | 25 | 7765N25 | Base | 1 |
| 6 | 7765N06 | Pin | 1 | 26 | 7765N26 | Screw & Washer | 4 |
| 7 | 7765N07 | Retaining Ring | 1 | 27 | 7765N27 | Spring Washer | 6 |
| 7A | 7765N07A | Wave Washer | 1 | 28 | 7765N28 | Rubber Post | 4 |
| 8 | 7765N08 | Retaining Ring | 2 | 29 | 7765N29 | Cap Screw | 2 |
| 9 | 7765N09 | O-Ring | 3 | 30 | 7765N30 | Cap Screw | 2 |
| 10 | 7765N10 | Speed Regulator | 1 | 31 | 7765N31 | Balancer Screw | 1 |
| 11 | 7765N11 | Exhaust Cover | 1 | 32 | 7765N32 | Plug | 1 |
| 12 | 7765N12 | Valve Spring | 1 | 33 | 7765N33 | Balancer | 1 |
| 13 | 7765N13 | O-Ring | 1 | 34 | 7765N34 | Bearing Housing | 1 |
| 13A | 7765N13A | O-Ring | 1 | 36 | 7765N36 | Bearing | 1 |
| 14 | 7765N14 | Valve Stem | 1 | 37 | 7765N37 | Bearing Plate | 1 |
| 15 | 7765N15 | O-Ring | 1 | 38 | 7765N38 | Washer | 1 |
| 16 | 7765N16 | Bearing | 2 | 39 | 7765N39 | Paper Clamp | 2 |
| 17 | 7765N17 | End Plate | 2 | 40 | 7765N40 | Flat Head Screw | 12 |
| 18 | 7765N18 | Cylinder | 1 | 40A | 7765N40A | Nut | 12 |
| 19 | 7765N19 | O-Ring | 1 | 41 | 7765N41 | Bearing Stop Screw | 1 |
| 19A | 7765N19A | Pin | 1 | 42 | 7765N42 | Shoe Plate | 1 |
| 20 | 7765N20 | Rotor | 1 | 43 | 7765N43 | Sanding Pad | 1 |
| | | | | 44 | 7765N44 | Muffler | 1 |
| | | | | 45 | 7765N45 | Screw & Lock Washer | 4 |

505 N. Railroad Ave. 33435
P.O. Box 1117 33425
Boynton Beach, Florida

FOR WARRANTY INFORMATION &
WARRANTY REGISTRATION VISIT
www.taylorpneumatic.com

Ph. (561) 732-1111
Fax (561) 731-4412
Toll Free 800-805-8665