

# T-7758R 1/4" Die Grinder

# T-7759R 1/4" Angle Die Grinder

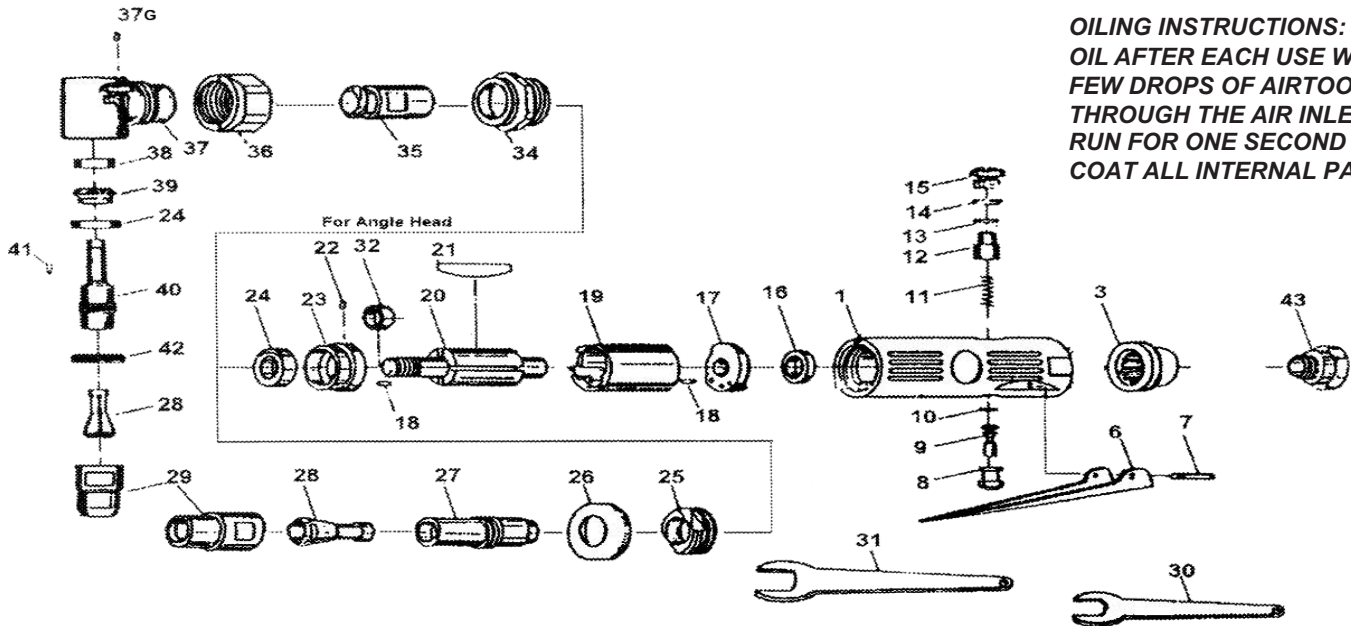

**OILING INSTRUCTIONS:**  
**OIL AFTER EACH USE WITH A FEW DROPS OF AIRTOOL OIL THROUGH THE AIR INLET. RUN FOR ONE SECOND TO COAT ALL INTERNAL PARTS.**

### USE 90 PSI MAXIMUM

Ref #	Part #	Description	Qty.	Ref #	Part #	Description	Qty.
1	7759R01N	Housing with Bushing	1	25	7758R25N	Bearing Cap	1
3	7759R03N	Exhaust Deflector	1	26	7758R26N	Nut	1
6	7759R06N	Lever	1	27	7758R27N	Spindle	1
7	7759R07N	Pin	1	28	T-7504	1/4" Collet	1
8	7759R08N	Throttle Bushing	1	28A	T-7508	1/8" Collet (not included)	
9	7759R09N	Valve	1	29	7759R29N	Clamp Nut	1
10	7759R10N	O-Ring	1	30	7759R30N	Wrench (11mm)	1
11	7759R11N	Spring	1	31	7759R31N	Wrench (17mm)	1
12	7759R12N	Regulator	1	32	7759R32N	Bushing	1
13	7759R13N	O-Ring	1	34	7759R34N	Nut	1
14	7759R14N	O-Ring	1	35	7759R35N	Bevel Gear	1
15	7759R15N	Cap	1	36	7759R36N	Nut	1
16	7759R16N	Bearing	1	37	7759R37N	Angle Head	1
17	7759R17N	Rear End Plate	1	37G	7759R37GN	Grease Fitting	1
18	7759R18N	Ball	2	38	7759R38N	Bearing	1
19	7759R19N	Cylinder	1	39	7759R39N	Bevel Gear	1
20	7759R20N	Rotor	1	40	7759R40N	Collet Casing	1
21	7759R21N	Rotor Blade (4 per set)	1 set	41	7759R41N	Key	1
22	7759R22N	Ball	1	42	7759R42N	Bearing Cap	1
23	7758R23N	Front Plate for T-7758R	1	43	7759R43N	Air Inlet	1
	7759R23N	Front Plate for T-7759R	1				
24	7759R24N	Bearing	1-2				

505 N. Railroad Ave. 33435  
P.O. Box 1117 33425  
Boynton Beach, Florida

FOR WARRANTY INFORMATION &  
WARRANTY REGISTRATION VISIT  
[www.taylorpneumatic.com](http://www.taylorpneumatic.com)

10/22TPTC /all rights reserved /COPYRIGHT 2022 / final

Ph. (561) 732-1111  
Fax (561) 731-4412  
Toll Free 800-805-8665

# Operating Instructions for Die Grinders

## GENERAL INFORMATION-

When a collet is attached to the output shaft of an airtool it is called a die grinder. It can have a straight handle or a pistol grip handle. Most of our die grinders will accept a 1/4" or 1/8" collets. The exceptions are the T-9930B & T-9930EXB's that have 3/8" collets. The four jawed collet we use on most die grinders gives the best grip and keeps the bit centered to minimize vibration. Make sure that the collet and collet holder are clean when installing a new bit, as chips and dirt in the collet can cause the tool to vibrate from being off center. The wrenches provided are used to tighten and loosen the collet nut. Check the collet nut periodically to keep it tight. When installing the bit (grinding stone, carbide burr, or cutoff wheel mandrel) push it in as far as it will go so that the actual working part of the bit is as close as possible to the collet nut, this ensures the best grip and minimizes vibration. Most die grinders have a built in regulator. Turning the valve with a flat bladed screwdriver will increase or decrease the amount of air going into the tool and increase or decrease the RPM. Use of a 3/8" air hose is recommended. Use the fewest number of quick disconnects possible to minimize air pressure drop. Air pressure at the tool should be 90 PSI or less. Using the least amount of pressure possible will allow you to get the maximum life from your tool. Small air compressors with tanks under 20 gallons may not provide enough air to maintain a constant 90 PSI.

Using too much air pressure is like driving your car at 200 MPH. Your car may go that fast, but will the tires, engine and bearings hold up? Excess air pressure can cause premature wear or tool failure. Most of our tools have safety levers that can prevent accidental starts. Removal is not recommended. Never drag a tool by the air hose, doing so can bend the rotor shaft causing permanent damage. Always check a die grinder, if it is dropped, for damage to the bit or a bent rotor shaft. The differences in die grinders is tremendous - pencil die grinders are used for fine work where size and weight are important. They come standard with 1/8" collets but 3/32" and 3mm collets are available. These tools also have overhoses for directing the exhaust away from the operator. The size of your job, as well as the amount of material to be removed, dictates the size of the die grinder you need to use. Pencil Grinders for light work in tight areas, the .25HP tools for light to medium material removal, the .45HP and .5HP units for heavy material removal. For really heavy duty jobs, use the .9HP tools. To keep dirt and grinding dust out of your tools, store them in plastic ziplock bags after oiling. If you have specific questions call us at 800-805-8665.

## SAFETY FIRST

Wearing safety glasses and the right clothing are important. Die grinders are usually high speed tools that can throw sparks and

grinding dust for several feet. Goggles are needed to protect your eyes, long sleeves will help protect your arms. The use of a full face shield may also be required. It is recommended that you remove jewelry such as rings and watches. Depending on how you use the tool, you may need to wear protective gloves. Hearing protection is needed when using a die grinder for extended periods of time. The stream of sparks (in the case of steel) or removed material (in the case of aluminum, wood or non-ferrous materials) can cause a fire or injury to a bystander. Pay attention to people around you and to the direction of the spark stream.

## OILING

Oiling your tool at the end of every day is extremely important. Add one or two tablespoons of a commercial airtool oil like our T-8004, T-8032 or T-8128 through the air inlet. Run the tool for a second or two to coat all internal parts. This will help prevent rust from forming.

**TAYLOR Airtool oil is custom blended to improve the life and performance of airtools. It will emulsify with water to protect against rust, and will loosen and flush out built up sludge and dirt.**

T-8128  
Gal. Air  
Tool Oil



T-8032  
Qt Air  
Tool Oil



T-8004  
4oz Air  
Tool Oil

