

T-7757D

3/8" High Speed Drill

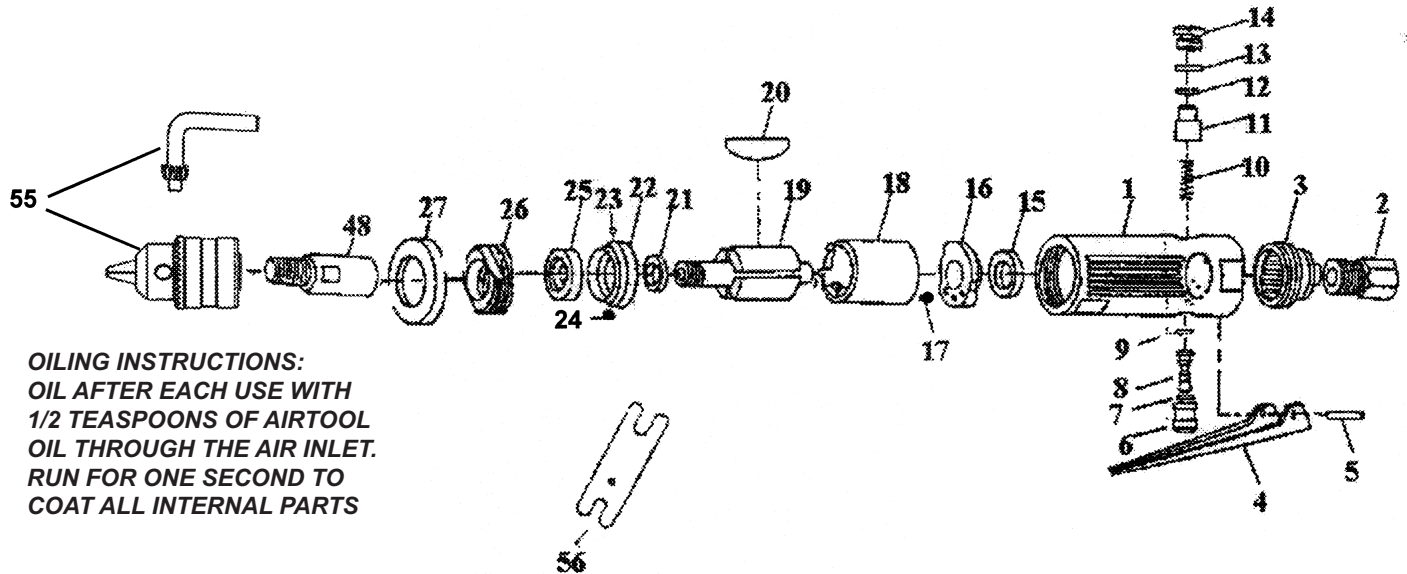

OILING INSTRUCTIONS:
 OIL AFTER EACH USE WITH
 1/2 TEASPOONS OF AIRTOOL
 OIL THROUGH THE AIR INLET.
 RUN FOR ONE SECOND TO
 COAT ALL INTERNAL PARTS

USE 90 PSI MAXIMUM

Ref #	Part #	Description	Qty.	Ref #	Part #	Description	Qty.
1	7757D01	Motor Housing	1	16	7757D16	End Plate	1
2	7757D02	Air Inlet	1	17	7757D17	Ball	1
3	7757D03	Exhaust Deflector	1	18	7757D18	Cylinder	1
4	7757D04	Throttle Lever	1	19	7757D19	Rotor	1
5	7757D05	Lever Pin	1	20	7757D20	Rotor Blades (4 per set)	1 set
6	7757D06	Bushing	1	21	7757D21	Stop Ring	1
7	7757D07	O-Ring	1	22	7757D22	Front Plate	1
8	7757D08	Valve	1	23	7757D23	Ball	1
9	7757D09	O-Ring	1	24	7757D24	Ball	1
10	7757D10	Valve Spring	1	25	7757D25	Bearing	1
11	7757D11	Air Regulator	1	26	7757D26	Cap	1
12	7757D12	O-Ring	1	27	7757D27	Spindle Nut	1
13	7757D13	O-Ring	1	48	7757D48	Chuck Spindle	1
14	7757D14	Throttle Plug	1	55	7788-C	3/8" Drill Chuck & Key	1
15	7757D15	Bearing	1	56	7757D56	Wrench	1

505 N. Railroad Ave. 33435
 P.O. Box 1117 33425
 Boynton Beach, Florida

SEE OUR CATALOG
 at
www.taylorpneumatic.com

12/15TPTC /all rights reserved /COPYRIGHT 2015 / final

Ph. (561) 732-1111
 Fax (561) 731-4412
 Toll Free 800-805-8665

Operating Instructions for Drills

PLEASE READ AND FOLLOW ALL WARNINGS

GENERAL INFORMATION-

Use of a 3/8" air hose is recommended. Use the fewest number of quick disconnects possible to minimize air pressure drop. Air pressure at the tool should be 90 PSI or less. Using the least amount of pressure possible will allow you to get the maximum life from your tool. Small air compressors with tanks under 20 gallons may not provide enough air to maintain a constant 90 PSI.

Using too much air pressure is like driving your car at 200 MPH. Your car may go that fast, but will the tires, engine and bearings hold up? Excess air pressure can cause premature wear or tool failure. Never drag a tool by the air hose, doing so can bend the rotor shaft causing permanent damage. Always check a drill, if it is dropped, for damage to the bit or a bent rotor shaft. The size of the hole you are drilling dictates the speed of the drill you need to use. Use slower speed drills for steel and higher speed drills for aluminum. To keep dirt and grinding dust out of your tools, store them in plastic ziplock bags after oiling. If you have specific questions call us at 800-805-8665.

1. ALWAYS DISCONNECT THE TOOL FROM AIR SOURCE WHEN CHANGING ACCESSORIES OR SERVICING THE TOOL.
2. CHECK ALL FASTENERS DAILY. BOLTS MUST BE KEPT TIGHT TO MAINTAIN SAFETY AND TOP TOOL OPERATING PERFORMANCE.
3. STAY IN CONTROL OF YOUR DRILL.
4. VIBRATION MAY BE HARMFUL TO YOUR ARMS AND HANDS. WEAR PROTECTION.
5. INSPECT THE TOOL AND AIR SUPPLY AND AIR HOSE ON A REGULAR BASIS.
6. DO NOT MAKE CONTACT WITH ELECTRICAL LINES.
7. LEAVE TRIGGER OFF BEFORE CONNECTING THE TOOL TO THE AIR SUPPLY. AVOID ACCIDENTAL STARTS.
8. WEAR THE PROPER CLOTHING. DO NOT WEAR JEWELRY, LOOSE CLOTHING, OR LONG HAIR AS IT CAN GET CAUGHT IN ROTATING PARTS. KEEP GLOVES AWAY FROM ROTATING PARTS.
9. DO NOT WORK IN HAZARDOUS ATMOSPHERES WHERE SPARKS COULD IGNITE OR DETONATE FUMES.
10. WATCH WHAT YOU ARE DOING. USE COMMON SENSE WHEN OPERATING PNEUMATIC TOOLS. DO NOT USE PNEUMATIC TOOLS WHEN TIRED OR UNDER THE INFLUENCE OF MEDICATION, ALCOHOL OR DRUGS. SERIOUS PERSONAL INJURY MAY RESULT FROM A MOMENTS INATTENTION.
11. USE 90 PSI AT THE TOOL. USE 3/8" HOSE
12. ONLY USE CLEAN DRY COMPRESSED AIR. NEVER USE OXYGEN, CARBON DIOXIDE, COMBUSTIBLE GASES OR ANY OTHER BOTTLED GAS TO POWER THIS TOOL.
13. STORE TOOLS IN A CLEAN DRY ENVIRONMENT.
14. DO NOT USE DAMAGED TOOLS - MARK, AND RETURN DAMAGED TOOLS FOR SERVICE.
15. NEVER FORCE THE TOOL. LET THE TOOL DO THE WORK.
16. STOP USE IMMEDIATELY IF TOOL IS MAKING AN UNUSUAL NOISE OR VIBRATION. HAVE TOOL CHECKED BY PROFESSIONAL TECHNICIAN.
17. KEEP CHILDREN, PETS AND BYSTANDERS AWAY WHILE OPERATING A PNEUMATIC TOOL. DISTRACTIONS CAN CAUSE YOU TO LOSE CONTROL.
18. THESE WARNINGS AND INSTRUCTIONS CAN NOT COVER ALL POSSIBLE CONDITIONS OR SITUATIONS. THE OPERATOR MUST UNDERSTAND THAT COMMON SENSE AND CAUTIONS ARE FACTORS WHICH CAN NOT BE BUILT INTO THE PRODUCT BUT MUST BE SUPPLIED BY THE OPERATOR.

ADDITIONAL INFORMATION IS AVAILABLE FROM:

**AMERICAN NATIONAL STANDARDS INSTITUTE
11 WEST 42ND ST.
NEW YORK, NY 10036**

REQUEST A COPY OF ANSI B186.1 SAFETY CODE FOR PORTABLE AIR TOOLS.

LIMITED LIFETIME WARRANTY

Most products of Taylor Pneumatic are warranted to be free from defects in material and workmanship for the life of the tool. This warranty applies to the original purchaser only. This warranty does not cover tools that have been abused, misused, modified, not properly lubricated or to normal wear and tear. Taylor Pneumatic will at its option repair or replace the defective product free of charge except for shipping. Taylor Pneumatics sole liability and your exclusive remedy under this warranty is limited to the repair or replacement of the defective product. There are no other warranties expressed or implied and Taylor Pneumatic shall not be liable for incidental, consequential, or special damages, expenses or costs except as described above. **WARRANTY VOID IF TOOL IS DISASSEMBLED.** Return tools to **Taylor Pneumatic**. Be sure to include your name, address, proof of purchase and description of the suspected defect.

This warranty applies to the basic tool. It does not apply to wear and tear on accessories or consumables such as drill chucks, backing pads for sanders, punch and dies for nibblers, spray gun cups or accessories from a kit.