

T-7604A Scaling Hammer

3 Piston Carbide Tipped

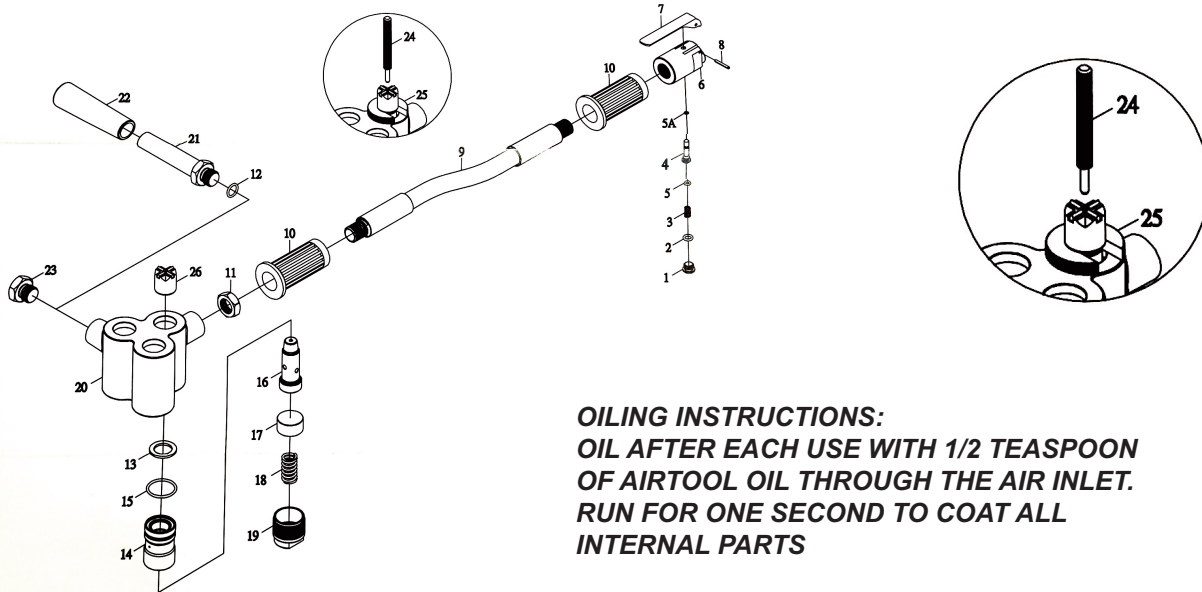

OILING INSTRUCTIONS:
OIL AFTER EACH USE WITH 1/2 TEASPOON
OF AIRTOOL OIL THROUGH THE AIR INLET.
RUN FOR ONE SECOND TO COAT ALL
INTERNAL PARTS

USE 90 PSI MAXIMUM

Ref #	Part #	Description	Qty.	Ref #	Part #	Description	Qty.
1	760401	Valve Cap	1	14	760414	Cylinder	3
2	760402	O-Ring	1	15	760415	O-Ring	3
3	760403	Valve Spring	1	16	760416	Piston	3
4	760404	Valve Stem	1	17	760417	Spring Cap	3
5	760405	O-Ring	1	18	760418	Spring	3
5A	760405A	O-Ring	1	19	760419	Plunger Cap	3
6	760406	Valve Body	1	20	7604A20	Body	1
7	760407	Throttle Lever	1	21	760421	Side Handle	1
8	760408	Roll Pin	1	22	760422	Secondary Rubber Handle	1
9	760409	Handle	1	23	760423	Plug	1
10	760410	Rubber Handle Grip	2	24	760424	Punch Pin	1
11	760411	Locknut	1	25	760425	Punch Plate	1
12	760412	O-Ring	1	26	760426	Head (Carbide Tipped)	3
13	760413	Wiper Seal	3				

505 N. Railroad Ave. 33435
P.O. Box 1117 33425
Boynton Beach, Florida

SEE OUR CATALOG
at
www.taylorpneumatic.com

12/15TPTC /all rights reserved /COPYRIGHT 2015 / final

Ph. (561) 732-1111
Fax (561) 731-4412
Toll Free 800-805-8665