

T-7511

2" Angle DA Sander

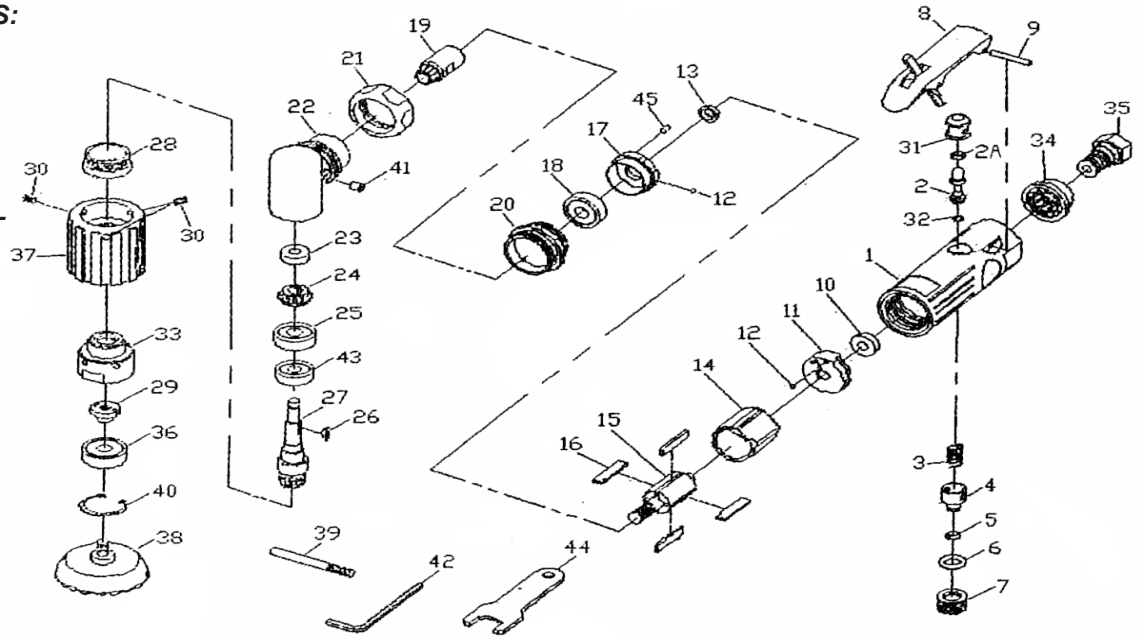

OILING INSTRUCTIONS:
OIL AFTER EACH USE
WITH A FEW DROPS
OF AIR TOOL OIL
THROUGH THE AIR
INLET. RUN FOR ONE
SECOND TO COAT ALL
INTERNAL PARTS.



USE 90 PSI MAXIMUM

Ref #	Part #	Description	Qty.	Ref #	Part #	Description	Qty.
1	751101	Motor Housing	1	25	751125	Bearing	1
2	751102	Valve Stem	1	26	751126	Spindle Key	1
2A	751102A	O-Ring	1	27	751127	Spindle	1
3	751103	Throttle Spring	1	28	751128	Clamp Nut	1
4	751104	Air Regulator	1	29	751129	Spindle	1
5	751105	O-Ring	1	30	751130	Hex Screw	3
6	751106	O-Ring	1	31	751131	Throttle Valve Bushing	1
7	751107	Valve Screw	1	32	751132	O-Ring	1
8	751108	Throttle Lever	1	33	751133	Housing	1
9	751109	Throttle Lever Pin	1	34	751134	Exhaust Deflector	1
10	751110	Bearing	1	35	751135	Air Inlet	1
11	751111	Rear End Plate	1	36	751136	Bearing	1
12	751112	Ball	2	37	751137	Cover	1
13	751113	Rotor Collar	1	38	751138	Pad 2" PSA	1
14	751114	Cylinder	1	38V	751138V	Pad 2" Velcro (optional)	-
15	751115	Rotor	1	39	751139	Wrench	1
16	751116	Rotor Blade (4 per set)	1 set	40	751140	C-Ring	1
17	751117	Front End Plate	1	41	751141	Grease Fitting	1
18	751118	Bearing	1	42	751142	Allen Wrench	1
19	751119	Gear	1	43	751143	Bearing	1
20	751120	Motor Clamp Housing	1	44	751144	Wrench	1
21	751121	Lock Ring	1	45	751145	Locating Pin	1
22	751122	Angle Head Housing	1				
23	751123	Bearing	1				
24	751124	Spindle Gear	1				

505 N. Railroad Ave. 33435
P.O. Box 1117 33425
Boynton Beach, Florida

FOR WARRANTY INFORMATION &
WARRANTY REGISTRATION VISIT
www.taylorpneumatic.com

Ph. (561) 732-1111
Fax (561) 731-4412
Toll Free 800-805-8665