

T-7308 1/4" HIGH SPEED DIE GRINDER FRONT EXHAUST

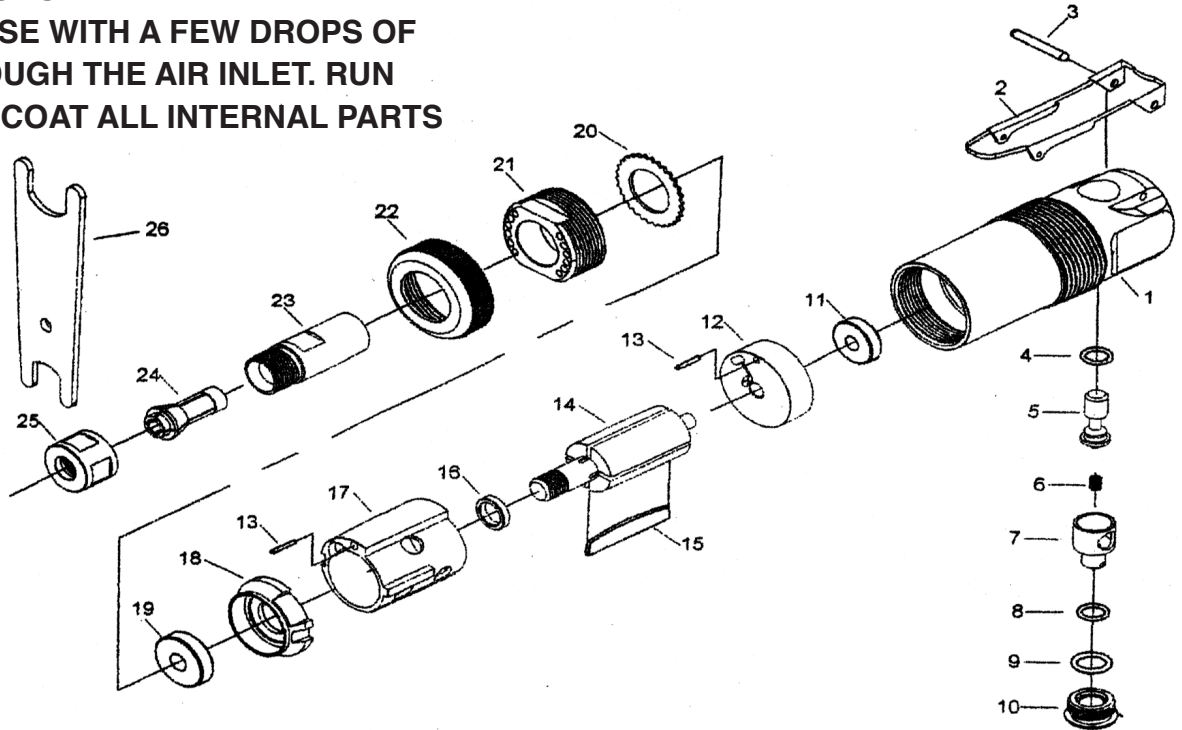

OILING INSTRUCTIONS:

OIL AFTER EACH USE WITH A FEW DROPS OF AIRTOOL OIL THROUGH THE AIR INLET. RUN FOR 1 SECOND TO COAT ALL INTERNAL PARTS



USE 90 PSI MAXIMUM

REF #	PART #	DESCRIPTION	QTY	REF #	PART #	DESCRIPTION	QTY
1	730801	MOTOR HOUSING W/ BUSHING	1	15	730815	VANE (SET OF 4)	1 set
2	730802	LEVER ASSEMBLY	1	16	730816	SPACER	1
3	730803	THROTTLE PIN	1	17	730817	CYLINDER	1
4	730804	O-RING	1	18	730818	FRONT END PLATE	1
5	730805	VALVE STEM	1	19	730819	BEARING	1
6	730806	SPRING	1	20	730820	EXHAUST DIFFUSER	1
7	730807	REGULATOR	1	21	730821	CLAMP NUT	1
8	730808	O-RING	1	22	730822	CAP	1
9	730809	O-RING	1	23	730823	COLLET BODY	1
10	730810	CAP	1	24	T-7504	1/4" COLLET	1
11	730811	BEARING	1	24A	T-7508	1/8" COLLET (OPTIONAL)	-
12	730812	REAR END PLATE	1	25	730825	COLLET NUT	1
13	730813	PIN	2	26	730826	WRENCH	2
14	730814	ROTOR	1				

505 N. Railroad Ave. 33435
P.O. Box 1117 33425
Boynton Beach, FL

FOR WARRANTY INFORMATION &
WARRANTY REGISTRATION VISIT
www.taylorpneumatic.com

Ph. (561)732-1111
Fax. (561)731-4412
Toll Free (800) 805-8665