

T-7121 AIR HAMMER (.401 SHANK)

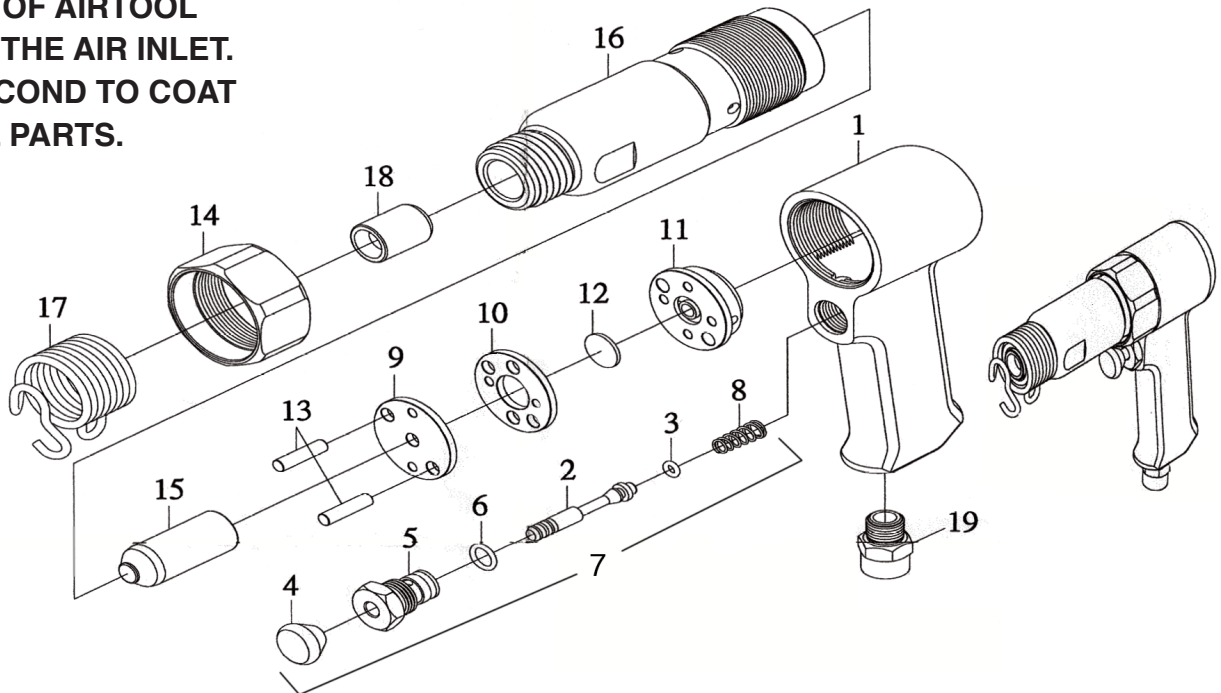

**OILING INSTRUCTIONS:
OIL AFTER EACH USE WITH
A FEW DROPS OF AIRTOOL
OIL THROUGH THE AIR INLET.
RUN FOR 1 SECOND TO COAT
ALL INTERNAL PARTS.**



USE 90 PSI MAXIMUM

REF #	PART #	DESCRIPTION	QTY	REF #	PART #	DESCRIPTION	QTY
1	712101	HANDLE	1	16	712116	CYLINDER	1
2	712102	THROTTLE VALVE	1	17	T-712117	RETAINER SPRING	1
3	712103	O-RING	1	18	712118	BUSHING	1
4	712104	TRIGGER BUTTON	1	19	712119	AIR INLET	1
5	712105	VALVE BUSHING	1			OPTIONAL ACCESSORIES	
6	712106	O-RING	1			FOR .401 AIR HAMMERS	
7	712107A	TRIGGER ASSEMBLY #2-#8	1			T-4030	TAPERED PUNCH
8	712108	SPRING	1			T-4040	COLD CHISEL
9	712109	VALVE SEAT	1			T-4060	SPOT WELD BUSTER
10	712110	VALVE SPACER	1			T-4090	SPECIAL PANEL CUTTER
11	712111	VALVE CAP	1			T-4100	DOUBLE BLADED CUTTER
12	712112	VALVE	1			T-4220	SCRAPER BLADE 1-1/4"
13	712113	PIN	2			712120	QUICK CHANGE RETAINER
14	712114	EXHAUST DEFLECTOR	1				
15	712115	PISTON	1				

505 N. Railroad Ave. 33435
P.O. Box 1117 33425
Boynton Beach, FL

FOR WARRANTY INFORMATION &
WARRANTY REGISTRATION VISIT
www.taylorpneumatic.com

Ph. (561)732-1111
Fax. (561)731-4412
Toll Free (800) 805-8665