

# T-7111C HAMMER/SCALER T-7151C HAMMER/SCALER

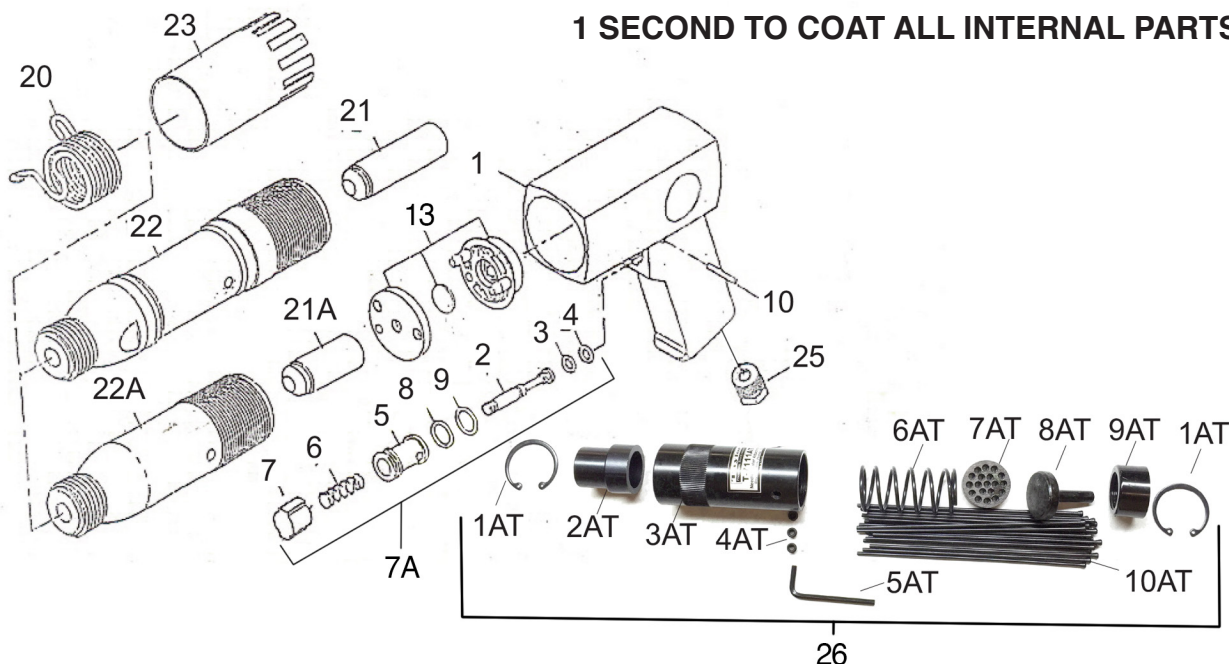

## OILING INSTRUCTIONS:

OIL AFTER EACH USE WITH A FEW DROPS OF AIRTOOL OIL THROUGH THE AIR INLET. RUN FOR 1 SECOND TO COAT ALL INTERNAL PARTS.



### USE 90 PSI MAXIMUM

REF #	PART #	DESCRIPTION	QTY	REF #	PART #	DESCRIPTION	QTY
1	715101A	HANDLE ASSEMBLY (INCLUDES: #1-10,25)	1set	22	715122	CYLINDER	1
2	715102	THROTTLE VALVE STEM	1	22A	711122	CYLINDER	1
3	715103	O-RING	1	23	715123	EXHAUST DEFLECTOR (T-7151)	1
4	715104	O-RING	1	25	715125	AIR INLET	1
5	715105	VALVE BUSHING	1	26	T-7111AT	NEEDLE SCALER ATTACHMENT (INCLUDES 1AT-9AT & NEEDLES)	1
6	715106	VALVE SPRING	1	1AT	715101AT	RETAINER RING	2
7	715107	VALVE BUTTON	1	2AT	715102AT	NOSE	1
7A	715107A	VALVE ASSEMBLY (2-9)	1set	3AT	715103AT	BODAY	1
8	715108	O-RING	1	4AT	715104AT	SET SCREW	3
9	715109	O-RING	1	5AT	715105AT	ALLEN WRENCH	1
10	715110	ROLL PIN	1	6AT	715106AT	SPRING	1
13	715113A	VALVE ASSEMBLY	1set	7AT	715107AT	NEEDLE HOLDER	1
20	T-5210	QUICK CHANGE SPRING	1	8AT	715108AT	NEEDLE DRIVER	1
20A	T-5120	BEEHIVE SPRING (OPTIONAL, NOT SHOWN)	1	9AT	715109AT	BUSHING	1
21	715121	PISTON	1	10AT	T-735646	NEEDLES (SET OF 19)	1set
21A	711121	PISTON	1				

505 N. Railroad Ave. 33435  
P.O. Box 1117 33425  
Boynton Beach, FL

FOR WARRANTY INFORMATION &  
WARRANTY REGISTRATION VISIT  
[www.taylorpneumatic.com](http://www.taylorpneumatic.com)

Ph. (561)732-1111  
Fax. (561)731-4412  
Toll Free (800) 805-8665