

T-7040A BELT SANDER

2.36" X 10.23" 7,000 RPM

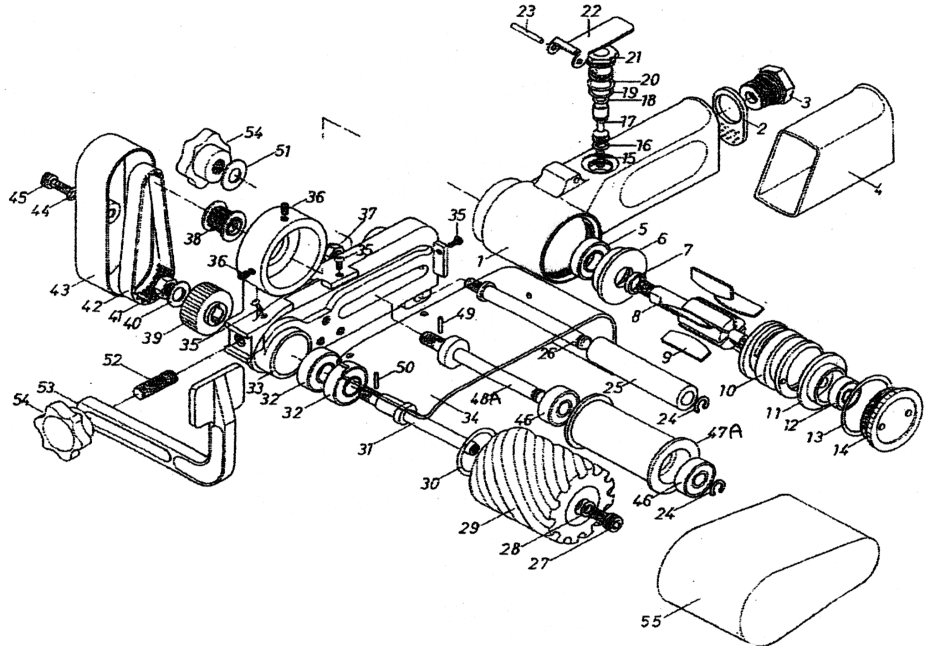

OILING INSTRUCTIONS:
OIL AFTER EACH USE
WITH A FEW DROPS OF
AIRTOOL OIL THROUGH
THE AIR INLET. RUN FOR
1 SECOND TO COAT ALL
INTERNAL PARTS

USE 90 PSI MAXIMUM

REF #	PART #	DESCRIPTION	QTY	REF #	PART #	DESCRIPTION	QTY
1	7040A01	MOTOR HOUSING	1	28	7040A28	WASHER	1
2	7040A02	DEFLECTOR	1	29	7040A29	ROLLER	1
3	7040A03	INLET BUSHING	1	30	7040A30	RETAINER	1
4	7040A04	HOUSING COVER	1	31	7040A31	DRIVE SHAFT	1
5	7040A05	BEARING	1	32	7040A32	BEARING	2
6	7040A06	FRONT END PLATE	1	33	7040A33	FRAME	1
7	7040A07	SPACER	1	34	7040A34	WHEEL COVER (CLEAR)	1
8	7040A08	ROTOR	1	35	7040A35	SCREW	3
9	7040A09	ROTOR BLADES (SET OF 5)	1set	36	7040A36	SET SCREW	2
10	7040A10	CYLINDER	1	37	7040A37	NUT	1
11	7040A11	REAR END PLATE	1	38	7040A38	PULLEY/SMALL	1
12	7040A12	BEARING	1	39	7040A39	PULLEY/LARGE	1
13	7040A13	O-RING	1	40	7040A40	WASHER	1
14	7040A14	CLAMP NUT	1	41	7040A41	NUT	1
15	7040A15	VALVE SPRING	1	42	7040A42	BELT	1
16	7040A16	O-RING	1	43	7040A43	BELT COVER	1
17	7040A17	VALVE STEM	1	44	7040A44	WASHER	1
18	7040A18	O-RING	1	45	7040A45	SCREW	1
19	7040A19	O-RING	1	46	7040A46	BEARING	2
20	7040A20	O-RING	1	47A	7040A47	IDLER ROLLER	1
21	7040A21	VALVE BUSHING	1	48A	7040A48	IDLER SHAFT	1
22	7040A22	THROTTLE LEVER	1	49	7040A49	ROLL PIN	1
23	7040A23	PIN	1	50	7040A50	ROLL PIN	1
24	7040A24	SNAP RING	2	51	7040A51	WASHER	1
25	7040A25	LEVEL ROLLER	1	52	7040A52	SCREW	1
26	7040A26	LEVEL SHAFT	1	53	7040A53	GUIDE	1
27	7040A27	SCREW	1	54	7040A54	KNOB	2
				55	7040A55	BELT(80 GRIT)	1

505 N. Railroad Ave. 33435
P.O. Box 1117 33425
Boynton Beach, FL

FOR WARRANTY INFORMATION &
WARRANTY REGISTRATION VISIT

www.taylorpneumatic.com

Ph. (561)732-1111
Fax. (561)731-4412
Toll Free (800) 805-8665